

SPRING 2016 REPORT

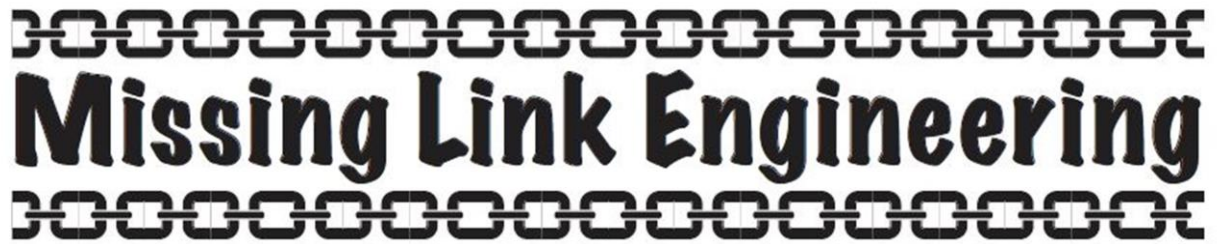

MacDon Industries, Ltd.

Adam McKay

Seth Cleary

Carson Brian

Andrew Farrand

OKLAHOMA STATE UNIVERSITY

Contents

| | |
|-------------------------------------|----|
| Table of Contents | 1 |
| List of Figures | 2 |
| List of Tables | 3 |
| List of Equations | 3 |
| Mission Statement | 5 |
| Introduction | 6 |
| Customer Requirements | 9 |
| Technical Requirements | 11 |
| Equipment Requirements..... | 11 |
| Standards..... | 12 |
| Windrower Capabilities..... | 14 |
| Header Selection Criteria..... | 17 |
| Project Impact | 19 |
| Design Concepts | 20 |
| Drawbar..... | 20 |
| Frame..... | 20 |
| Hydraulic Circuit..... | 31 |
| Flow Combination Manifold..... | 35 |
| Mounting..... | 37 |
| Wiring and Speed Sensor..... | 40 |
| Operation..... | 42 |
| Safety..... | 44 |
| Hydraulic Safety..... | 45 |
| PTO Safety..... | 45 |
| Flying Debris Safety..... | 47 |
| Prototype | 48 |
| Testing | 49 |
| Recommendations | 55 |
| Prototype Budget | 57 |
| Project Schedule | 58 |
| References | 59 |

Appendix..... 60

Fall Semester Frame Design Stress Life Calculation 60

Hydraulic Manifold Drawings (units in inches) 62

Structural Member Drawings (units in mm) 64

Speed Sensor Pickup Plate (units in inches) (designed by Mr. Wayne Kiner) 77

Hydraulic Mounts (units in mm)..... 78

Assembly Drawings (units in mm) 80

List of Figures

Figure 1: MacDon M155 Self-Propelled Windrower from M155 operator’s manual..... 5

Figure 2: A display of countries with a strong MacDon presence from MacDon’s website.. 6

Figure 3: MacDon’s Dual Direction® system allows the windrower to be driven engine forward, from M155 operator’s manual..... 7

Figure 4: Illustration of changing direction of travel in the windrower from MacDon website..... 8

Figure 5: Windrower with weight box pulling a header from M155 owner’s manual..... 9

Figure 6: Button layout of GSL (Ground Speed Lever) from M155 owner’s manual..... 10

Figure 7: CDM (Cab Display Module), M155 Manual 10

Figure 8: PTO Shield Schematic from ASABE/ISO 500-1:2014..... 13

Figure 9: Figure for dimensions of hydraulic outlet location from ANSI/ASAE S366.2 MAY2004..... 14

Figure 10: Force on Axle Specifications..... 15

Figure 12: John Deere Category 2 Drawbar 20

Figure 13: Side view of MacDon weight box from M155’s owner’s manual..... 21

Figure 14: Square frame, plate mounting..... 24

Figure 15: Redesigned Mule Frame 25

Figure 16: Left Side Boot 26

Figure 17: Right Side Boot..... 26

Figure 18: Two Piece Frame Members..... 27

Figure 19: Access Port 27

Figure 20: Drawbar Housing..... 28

Figure 21: Side View of Support Skids 29

Figure 22: Anti-Torsion Gussets..... 29

Figure 23: Frame Stress Analysis 30

Figure 24: Displacement Analysis 30

Figure 25: Parker Hannifin Pump Model 31

Figure 26: Comer A640 Gearbox 32

Figure 27: Parker Hannifin Pump Operation Speed 32

Figure 28: Hydraulic Circuit 34

| | |
|--|-----------|
| Figure 29: Hydraulic Manifold..... | 35 |
| Figure 30: Manifold Static FEA with 4000 psi..... | 36 |
| Figure 31: Manifold Flow Combination Illustration..... | 36 |
| Figure 32: Stucchi Check Valves..... | 37 |
| Figure 33: PTO Mount..... | 38 |
| Figure 34: PTO Mount Bottom View..... | 38 |
| Figure 35: Single Point Hydraulic Mount..... | 39 |
| Figure 36: Hydraulic Manifold Mount..... | 39 |
| Figure 37: Header ID Wiring Diagram M155..... | 40 |
| Figure 38: Trailer Wiring Connection..... | 40 |
| Figure 39: Speed Sensor from R85 Header..... | 41 |
| Figure 40: Speed Sensor Pickup..... | 41 |
| Figure 41: Header Engage/Disengage Switch from M155 operator’s manual..... | 42 |
| Figure 42: Auxiliary hydraulic coupling plate from D65 owner’s manual..... | 43 |
| Figure 43: Auxiliary hydraulics attached to coupling plate from D65 owner’s manual..... | 43 |
| Figure 44: Knife and Draper Hydraulic Connection points PTO power from D65 owner’s manual..... | 43 |
| Figure 46: Pioneer quick coupler from McMaster-Carr..... | 44 |
| Figure 47: PTO master shield stress simulation with 1200 N load and 11 gauge A36 steel..... | 46 |
| Figure 48: PTO master shield deflection simulation with 1200 N load and 11 gauge A36 steel..... | 46 |
| Figure 49: PTO Safety Sign..... | 47 |
| Figure 50: Project Prototype: The Mule 2.0..... | 48 |
| Figure 51: Draper Hydraulic Motor Adjustment Diagram from M155 Tech Manual..... | 49 |
| Figure 52: PTO Dynamometer Testing Setup..... | 50 |
| Figure 53: PTO Power Curve from First Test..... | 51 |
| Figure 54: Pressure Gauge Plumbed into Knife Circuit..... | 52 |
| Figure 55: PTO Dynamometer Test with only Knife Circuit Operated Manually..... | 53 |
| Figure 56: Hydraulic Auxiliary Outlets..... | 54 |
| Figure 57: Recommended prototype..... | 55 |
| Figure 58: Pure Bending Factor of Safety Calculations..... | 60 |
| Figure 59: Split Bending and Shear Factor of Safety Calculations..... | 60 |
| Figure 60: Split Bending and Shear Stress Factor of Safety Calculations with Flat Plate .. | 61 |

List of Tables

| | |
|--|-----------|
| Table 1: Task List for Project Completion..... | 8 |
| Table 2: Analysis of power requirements for balers..... | 11 |
| Table 3: PTO Shield Dimensions..... | 12 |
| Table 4: Drawbar Category Chart from ANSI/ASABE AD6489-3..... | 16 |
| Table 5: Calculation of Power to Wheels of Windrower..... | 16 |
| Table 6: Maximum Header Configuration Knife Drive Power..... | 17 |

| | |
|---|----|
| Table 7: Header Identification and Specification Chart | 18 |
| Table 8: Available Power | 33 |
| Table 9: Available Power Using a 2:1 Gearing | 33 |
| Table 10: Available Power Using a 3:1 Gearing | 34 |
| Table 11: Stucchi Check Valve Specifications | 37 |
| Table 12: Knife Circuit Theoretical Horsepower Calculation | 51 |
| Table 13: Prototype budget breakdown | 57 |
| Table 14: Project Work Breakdown Structure | 58 |

List of Equations

| | |
|---|----|
| Equation 1: Torque Calculation for Hydraulic Motor | 16 |
| Equation 2: Rotational Velocity | 17 |
| Equation 3: Power Equation | 17 |
| Equation 4: Static force equations | 21 |
| Equation 5: Force to begin moving a fully loaded implement | 22 |
| Equation 6: Endurance limit | 22 |
| Equation 7: Bending stress | 23 |
| Equation 8: Equation for hydraulic horsepower | 33 |
| Equation 9: Tangential Stress in a Pressurized Cylinder | 35 |
| Equation 10: Static factor of safety | 45 |

Mission Statement

Our mission at Missing Link Engineering is to take new and existing technologies and implement mergers between problems brought to us by industry. We strive to create solutions that meet the need of a target audience and create powerful, thoughtful solutions that maximize the profitability of our customers. We find the missing link between real world problems and technical solutions.



Figure 1: MacDon M155 Self-Propelled Windrower from M155 operator's manual

Introduction

MacDon Industries, LTD. is an OEM (original equipment manufacturer) headquartered out of Winnipeg, Manitoba. They have been world leaders in the technology, innovation and manufacturing of high quality, high performance harvesting equipment for over 65 years, beginning back in 1949 as Killbery. MacDon has a global presence of over 40 countries, on 6 continents as Figure 2 shows. These products range from hay equipment such as rotary and auger header pull-type windrowers, to pick-up and draper headers for combine harvesters. Additionally, they produce a line of self-propelled windrowers designed to operate rotary, auger and draper headers for a variety of uses to producers.



Figure 2: A display of countries with a strong MacDon presence from MacDon’s website

A used self-propelled windrower can cost roughly \$100,000 from a reputable dealer and a new windrower can cost upwards of \$150,000. Purchasing a tractor after the purchase of an expensive windrower can be a difficult proposition. For many small farming operations it is not economically sound for them to make this kind of investment. A farming operation that requires the use of a windrower also requires a tractor to power implements such as small, square and round balers as well as grain augers and other low horse power non-tillage implements. MacDon’s patented Dual Direction® windrowers (U.S. Patent 7159687B2), as seen in Figures 3 and 4, provides the opportunity for a unique solution to this issue. By mounting a drawbar and

hydraulically driven PTO (power take-off) to the header connections, the MacDon M155 windrower can replace many tractor functions.

6.3.6.3 Engine-Forward Operation

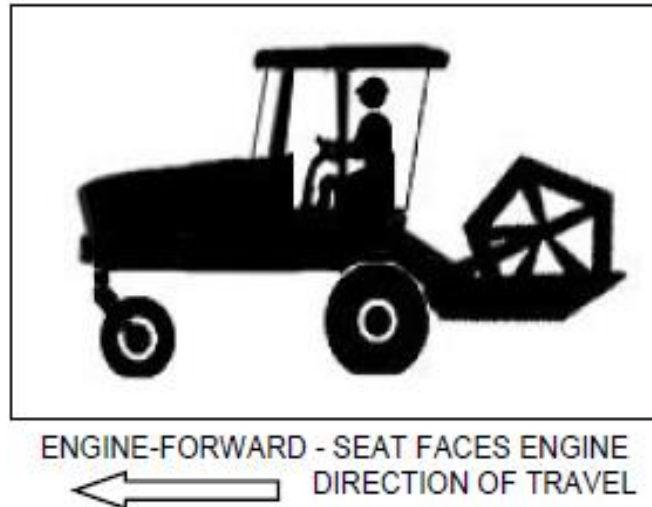

Figure 3: MacDon's Dual Direction® system allows the windrower to be driven engine forward, from M155 operator's manual

With this issue in mind, Missing Link Engineering has provided a solution to maximize the flexibility and capabilities of MacDon windrowers with the following problem statement in mind:

The goal of this project was to create an economical and reliable apparatus to attach to a MacDon M155 windrower, using the attachment points that come factory installed on the windrower. This apparatus will make the windrower capable of both powering, via PTO, and pulling small, non-tillage implements while also having a bank of auxiliary Pioneer hydraulic outlets. This attachment can create a year round usage for a piece of equipment that is normally only used for a small portion of the working year.

The scope of the project covers the design, prototyping, and testing of a hitch assembly to attach to an M155 windrower. The hitch assembly was designed with a multi-position drawbar, hydraulically powered PTO, and a bank of hydraulic outlets. The overall cost of components was modelled within MacDon's criteria to make the system more desirable to consumers. Missing Link Engineering explored the feasibility and practicality of the system having a self-contained transport system as opposed to it being free standing for hookup. The deliverables of the project include an apparatus capable of trailering and powering small non-tillage implements with either a transport system or an apparatus to make the apparatus self-supporting when not mounted to the windrower.

Missing Link Engineering proposed the addition of a transport kit to the attachment to allow it be pulled to the field by a pickup truck. This would act in place of a three point support setup that would allow the attachment to be free standing when not attached to the windrower but

otherwise immobile. We compared the viability of both options in this report. The added benefit of the transport option was found to be unfeasible for the price target given by our clients. Further iterations once the products gains sales momentum could cause a revisit of this idea. The tasks required to complete the entire project are outlined below in Table 1:

Table 1: Task List for Project Completion

| Task | Finish Date |
|--------------------------------------|--------------------|
| Define Client Requirements | 10/01/2015 |
| Research Applicable Patents | 10/15/2015 |
| Establish Multiple Design Ideas | 10/30/2015 |
| Run Calculations/Analysis On Ideas | 11/15/2015 |
| Write Fall Design Presentation | 11/20/2015 |
| Fall Presentation to Client | 12/04/2015 |
| Prototype Fabrication Complete | 4/15/2016 |
| Verification of Prototype Components | 4/19/2016 |
| Write Final Report | 04/13/2016 |
| Spring Presentation to Client | 04/28/2016 |
| Final Deliverables Due | 05/05/2016 |

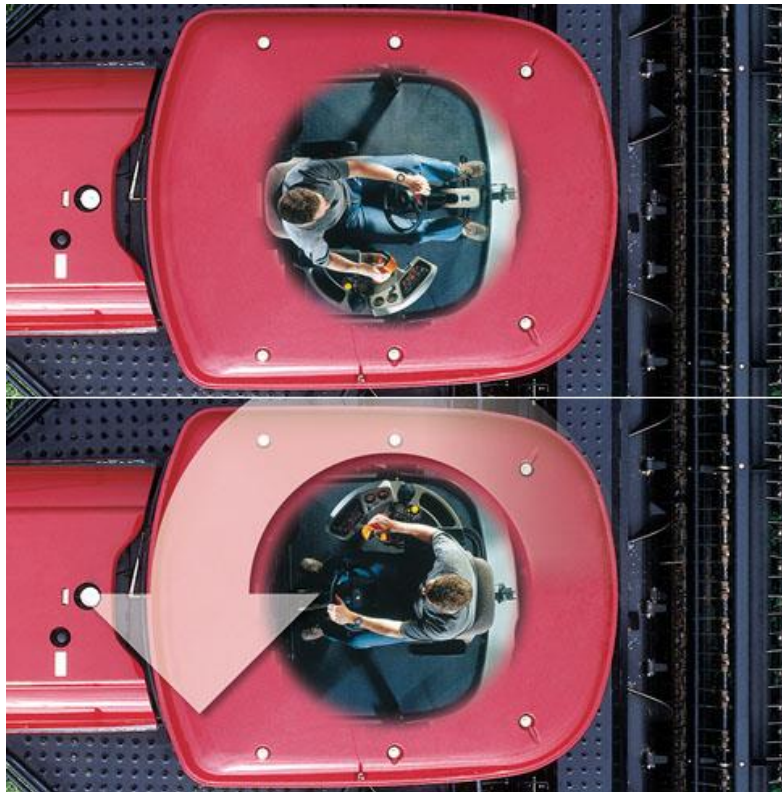

Figure 4: Illustration of changing direction of travel in the windrower from MacDon website

Customer Requirements

For this project, Missing Link Engineering designed an attachment for the operators of an M155 self-propelled windrower that uses the same mounting points as a standard rotary or platform windrower header. The prototype made use of a drawbar and PTO in order to be universally compatible with multiple pieces of agricultural equipment.

The prototype was designed and fabricated using many parts currently within Macdon's part catalogs. Macdon, as the manufacturer and marketed brand, could utilize existing part contracts with suppliers to cut the cost further for the attachment. As such to maximize profitability and to evade bidding of overlapping parts the majority of prefabricated parts were designed around MacDon's current catalog.

Criteria which would constitute a successful design included the following economic and fabrication requirements. Bend radii were required to be designed at least 3mm or higher. The projected total cost would be \$3500, including labor and materials. The suggested MSRP would be \$5000 which would constitute a profit of 40%. After the Fall Presentation a reiteration of the design budget was agreed upon by the clients of \$6000 for prototype cost.

The attachment should be easy to connect to the windrower using existing header attachments points on the windrower. All auxiliary outlets to other equipment should use Pioneer® quick connect couplers. The overall design should seamlessly mesh with both MacDon's M155 windrower and with most commercial, non-tillage farm equipment which could be connected to the attachment. Additionally, all connections that would be needed to connect the attachment must be self-contained within the attachment.

For safe operation and a long working life, all structural components were designed with a static factor of safety of 1.5-2.5 and dynamic factor of safety from 3-4. The system will operate with the lift arms in their locked down position to prevent the hitch height from varying during operation. This is the same setup used for when the windrower is pulling a header with a weight box attached as seen in Figure 5 below.



Figure 5: Windrower with weight box pulling a header from M155 owner's manual

The Power Take Off (PTO) will be hydraulically powered using the existing pumps and control blocks for a standard M155 windrower with the DWA (Double Windrow Attachment) and draper header hydraulic circuits. The PTO should follow industry standards for safety and connections. The attachment should not force the retrofit of existing windrowers beyond normal

header attachments. The PTO needed to have a desired output power that would be viable for most non-tillage equipment (i.e. hay rake or baler).

The design needed to include a bank of Pioneer hydraulic outlets. Control of outlets in the bank will then be regulated using the joystick controls on the GSL, as seen in Figure 6 and Figure 7. The speed of the PTO is adjustable by control of the joystick and utilizes the existing speed readouts in the cab interface.

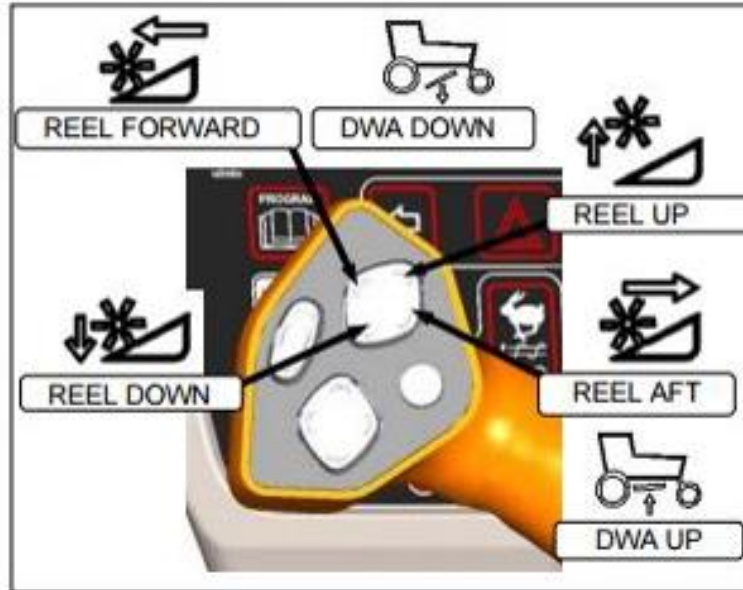

Figure 6: Button layout of GSL (Ground Speed Lever) from M155 owner’s manual

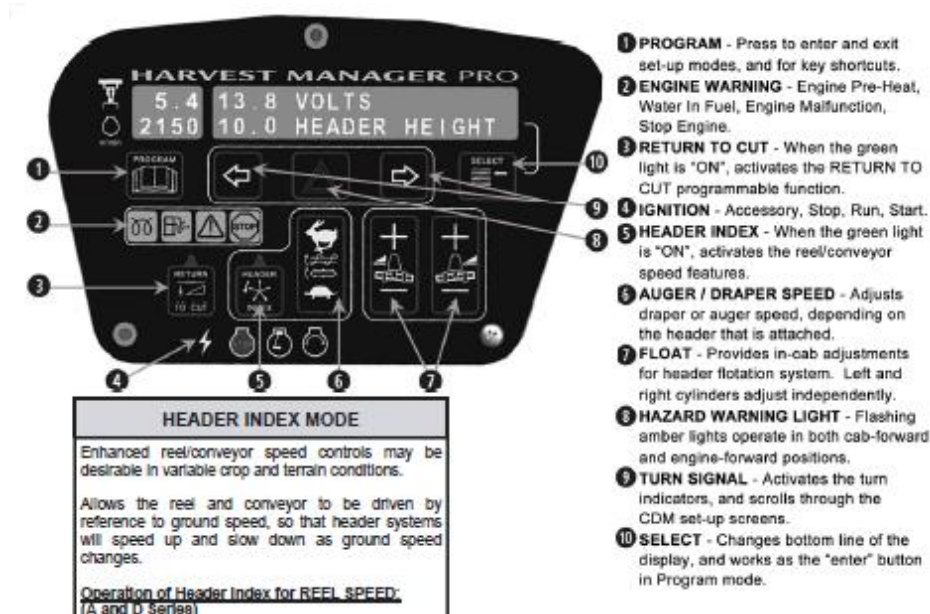

Figure 7: CDM (Cab Display Module), M155 Manual

Technical Requirements

Equipment Requirements

One of MacDon’s original requirements was to explore the practicality of an attachment that have the option of either a 540 or 1000 RPM PTO to increase the potential applications of the windrower. This request was explored by setting design criteria around implements that would have the highest probability of use and maximum horsepower requirements. The largest implement that needed to be powered and pulled was a round bale hay baler. The summary of this analysis can be seen in Table 2. This table shows a compilation of balers produced by New Holland, John Deere, Vermeer, and Massey Ferguson. The 38 balers sampled varied from 4ft x 5ft to 5ft x 6 ft bale configurations. All balers in this sample that exceeded 100 HP required were omitted as outside of project scope upon consulting with the MacDon. The average horsepower was 61 HP (45.5 KW). The most common power requirement was 70 HP (52 KW). Additionally, 34 of the 38 balers had a 540 PTO option while only 15 balers had a 1000 PTO option. Using this sample the suggested technical requirements were set as: the target power output from the PTO should be designed to power at least 70 HP (52 KW) and have a 540 rpm PTO shaft. All attachments within this power category used a 540 shaft. This led to the design of the attachment around just a 540 PTO option to simplify the design.

The max drawbar weight (Table 2) was designed as 1760 lbs or 7829 N from the sampled Massey Ferguson 2846/2926A which had the highest weight on drawbar. Max drawbar draft was modeled around a Vermeer 504 Pro Silage baler which had the highest of all balers sampled. Max drawbar draft was calculated using a rolling coefficient of static friction of 0.35 (engineeringtoolbox.com) which was multiplied by the normal force of the maximum combined base weight of a baler and its heaviest bale and subtracting the drawbar weight with a base weight of 8300 lbs or 36920 N and a max bale weight of 2400 lbs or 10675 N and max drawbar weight of 1400 lbs or 6227 N.

Table 2: Analysis of power requirements for balers

| Baler Analysis | |
|-------------------------|-------|
| Number of brands | 4 |
| Number of balers | 38 |
| Most common HP | 70 |
| Average HP | 61 |
| 540 PTO option | 34 |
| 1000 PTO option | 15 |
| Max Drawbar Weight (N)* | 7829 |
| Max Drawbar Draft (N)** | 14354 |

*Massey Ferguson 2946/2946A

**Vermeer 504 Pro Silage

Standards

The PTO master shield for the PTO shaft is another highly important aspect of the design. Without this preventative tool, risk of injury can arise. Specifications for PTO shields are outlined in ASABE/ISO Standard 500-1. The shield for the PTO is a preventative measure to protect the operator and machinery from grave situations that can possibly happen when operating farm equipment. The PTO master shield geometry is shown in Figure 8 which is listed below. The shield dimensions are based off the type 1 PTO which are used for the drawbar standards and PTO placement standards. Figure 8 also displays the optional shape of the shield to a certain extent. The top of the shield can either be more round or more straight with a sharper angle to connect the top of the shield. On the sides of the shield the shield can either be straight down with a rounded edge or tapered back towards the PTO shaft with a harder angle back towards the windrower. These optional shapes are shown below in Figure 8. Table 3 shows the dimensions of the shield based on the type 1 PTO. This includes minimum and maximum dimensions, with variable dimensions also. The hole for the safety chain in Figure 8 is shown by the number 1.

Table 3: PTO Shield Dimensions

| | | |
|---------------|---------|-----|
| A (mm) | minimum | 76 |
| α | minimum | 60° |
| β | minimum | 50° |
| γ | minimum | 45° |
| SRr (mm) | maximum | 76 |
| K (mm) | minimum | 70 |
| $m \pm 5$ mm | | 125 |
| $n \pm 5$ mm | | 85 |
| $p \pm 10$ mm | | 290 |
| r (mm) | maximum | 76 |

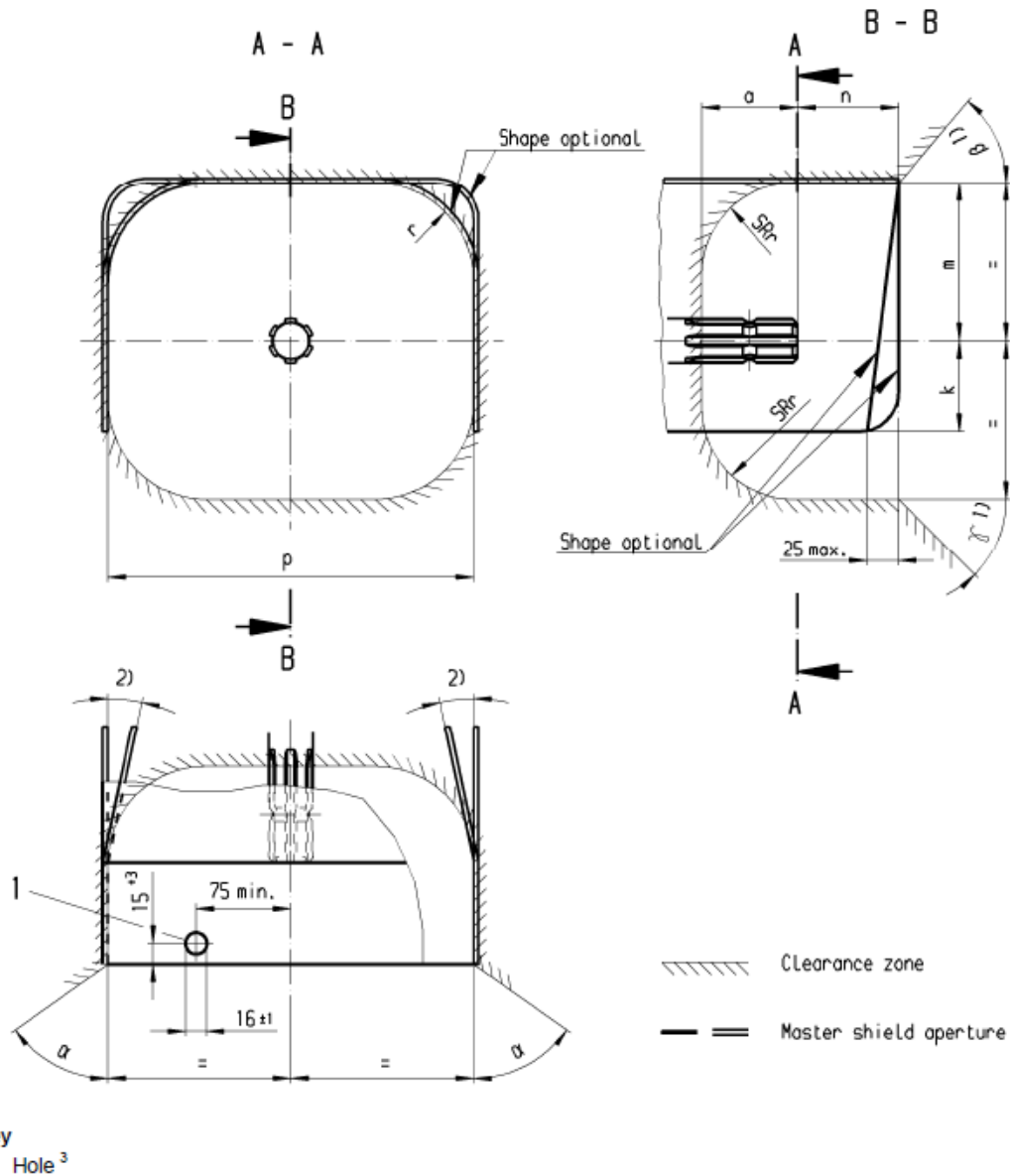
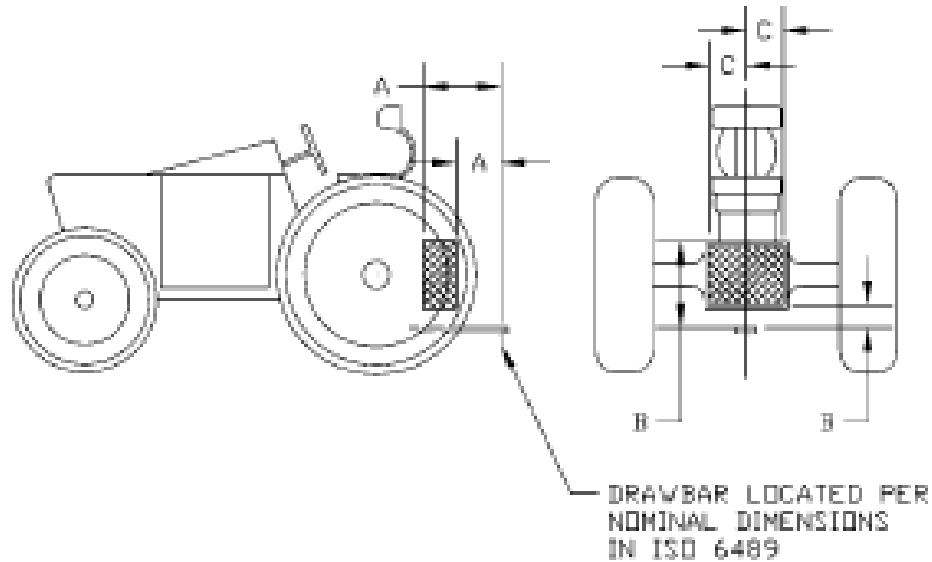

Figure 8: PTO Shield Schematic from ASABE/ISO 500-1:2014

Figure 9 shows the area that auxiliary hydraulic outlets should reside within at the rear of the tractor in accordance with ANSI/SAE S366.2 May 2004. In order to meet this standard lines were run in order to connect into the outlets on the gearbox mounting. This will ensure that the attachment can connect to any standard piece of equipment without having to add hydraulic extension hoses.



| <u>REAR LOCATION</u> | <u>DIMENSION RANGE</u> |
|----------------------|------------------------|
| A | 230-635 mm |
| B | 300-1015 mm |
| C | 300 MAX. |

Figure 9: Figure for dimensions of hydraulic outlet location from ANSI/SAE S366.2 MAY2004

Windrower Capabilities

Figure 10 from the M155's owner's manual displays the maximum allowable force on each axle. These specification were used to calculate the maximum force that the front axle could support safely. By subtracting the minimum weight on the front axle from the maximum weight we determine that our maximum combined vertical force of our attachment and the weight placed on the drawbar from an implement has to stay under 8680 lbf. This is taken into account both in the design of the attachment and when considering the largest implements that can be pulled by it. The value from Table 5 of Maximum static vertical load for short drawbar configuration of 22 kN or 4946 lbf can be viewed as our potential maximum drawbar load. Subtracting this value from the previously stated maximum combined of hitch attachment and implement of 8680 lbf. This specification makes the max allowable attachment weight 3734 lbf (16.6kN). This force is assumed to be the combined force exerted by the attachment and whatever implement is being pulled by the windrower.

- To prevent machine damage and/or loss of control, it is essential that the machine be equipped such that weights are within the following limits:

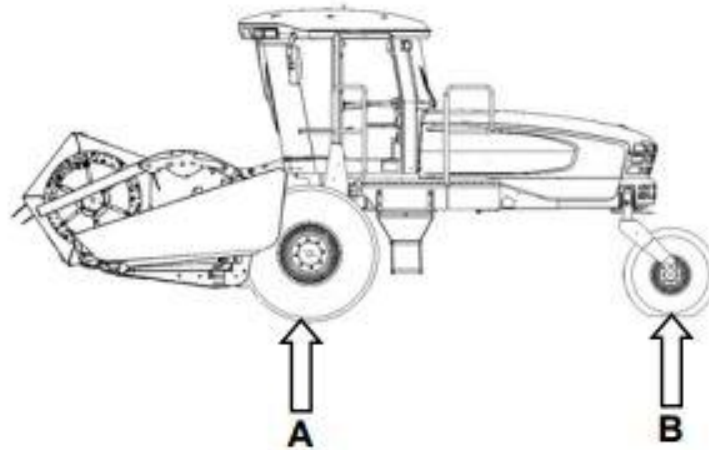

| | | LB | KG |
|--|----------------|--------|--------|
| MAX GWW (includes mounted implements). | | 21,500 | 9,750 |
| MAX CGWV (includes towed and mounted implements). | | 23,100 | 10,480 |
| WEIGHT "A" ON BOTH DRIVE WHEELS. | MAXIMUM | 18,750 | 8,500 |
| | MINIMUM | 10,070 | 4,570 |
| MAX WEIGHT "B" ON BOTH CASTER TIRES. | | 6,050 | 2,750 |

Figure 10: Force on Axle Specifications

The available hydraulic power from an M155 windrower is dependent on the flowrate and pressure. All headers that can be used with the M155 use the knife drive which has a pressure of 4000psi and a variable flowrate based on header selection. The required outputs of the project include the PTO power and the ability to use 5 outlets with 2 sets of dual acting and 1 single acting. Of the available set ups, only a draper header selection would have the ability to power the hydraulic outlets. Thus, the hydraulic circuit was designed around a draper header and the subsequent connections that it uses. This will be expanded upon later.

After the PTO target horsepower was established, the drawbar category for the attachment could be determined. From ANSI/ASABE AD6489-3, Table 4, the drawbar category was established to be 2.

Table 4: Drawbar Category Chart from ANSI/ASABE AD6489-3

| Drawbar Category | PTO power at rated engine (HP) |
|------------------|--------------------------------|
| 0 | ≤ 37 |
| 1 | ≤ 64 |
| 2 | ≤ 154 |
| 3 | ≤ 248 |
| 4 | ≤ 402 |
| 5 | ≤ 671 |

The power supplied to the wheels was calculated to ensure that the drawbar category of 2 was reasonable for the windrower. Input values were pulled directly from the M155 technical manual assuming that the attachment will be operated in field in low range. Equations 1, 2, and 3 were used for calculations. The theoretical horsepower of 128 places the windrower reasonably within the drawbar category of 2.

Table 5: Calculation of Power to Wheels of Windrower

| Power to Wheels Calculations | | | | | | |
|-------------------------------------|---------|---------|-----------|-----------|-------------|--------|
| V_m (in ³ /rev) | Q (gpm) | P (psi) | T (lb*in) | T (lb*ft) | n_m (rpm) | P (HP) |
| 4.15 | 40 | 5500 | 3633 | 303 | 2227 | 128 |

Equation 1: Torque Calculation for Hydraulic Motor

$$T = \frac{\Delta P * V_m}{2\pi}$$

Where:

- T = torque in lb*in
- ΔP = pressure in psi
- V_m = geometric volume of the wheel motors in in³/rev

Equation 2: Rotational Velocity

$$n_m = \frac{Q}{V_m}$$

Where:

- n_m = rotational velocity in rpm
- Q = flowrate in gpm

Equation 3: Power Equation

$$P = \frac{T * n_m}{5252}$$

Where:

- P = power in HP

Header Selection Criteria

The M155 self-propelled windrower’s hydraulic setup is dependent on two factors. The first is the physical configuration of the windrower and its hydraulic control blocks and lines. The second is the header identification which is based on the physical wiring harness plugin. In this section both factors are discussed.

In order to attain the flowrate and pressure requirements to achieve 70 hp a header must use more than the power achievable by the knife drive as shown in Table 6. Additionally in order to provide power to the quick couplers other hydraulic functions must be available. Figure () was used in order to find flowrates for the main header drive and the pin ID for select M155 headers. The R80 or R85 meets the flowrate requirements through use of the M2 circuit, but has no auxiliary drives that can be used to power the hydraulic outlets. Both the auger and draper configurations would allow for the use of both the PTO and hydraulic outlets. With this being said, the current windrower configuration of the prototype is that of a draper header. Being as such in order to lower refitting costs the draper 15ft header with the header ID of 0100 will be used.

Table 6: Maximum Header Configuration Knife Drive Power

| Knife Circuit | | | |
|----------------------|------------------------|----------------|------------|
| Header Type | Maximum Flowrate (GPM) | Pressure (PSI) | Power (HP) |
| Rotary | 30 | 4000 | 70 |
| Auger | 29.5 | 4000 | 69 |
| Draper | 29 | 4000 | 68 |

The header identification is based on the wiring harness plugin pins. The CDM reads the identification based on a binary system for four pins. The H pin of the wiring harness needs to be hot in order for the identification to be read and the correct setup to be initiated for the windrower. The windrower will need a wiring harness that will identify the correct header ID as

well as the capability to use a trailering harness. The use of the draper configuration also allows for the use of a reel speed sensor that can be read from the CDM. The design of the hydraulic circuit was based on this configuration as detailed in the design concepts.

Table 7: Header Identification and Specification Chart

| Header Type | PIN Code | Max flow (gpm) | Load stall (psi) @ 0 gpm |
|---------------------------|-----------------|-----------------------|---------------------------------|
| R80/R85 Disc on M155 | 0001 | 27-30 | 4000-4200 |
| A40-D Auger | 0011 | 26.5-29.5 | 4000-4200 |
| A30-D Auger | 0110 | 26-28 | 4000-4200 |
| A30-S Auger | 0010 | 22-23 | 4000-4200 |
| GSS Auger | 1010 | 26.5-29.5 | 4000-4200 |
| D-Series Draper DK | 0100 | 26.5-29 | 4000-4200 |
| D-Series Draper DK | 1111 | 21-24 | 4000-4200 |
| D-Series Draper DK | 0111 | 19.5-23 | 4000-4200 |
| D-Series Draper DK | 1101 | 18-21 | 4000-4200 |
| D-Series Draper DK | 1100 | 18-21 | 4000-4200 |
| D-Series Draper SK | 1101 | 14.5-17.5 | 4000-4200 |
| D-Series Draper SK | 0101 | 18-21 | 4000-4200 |
| D-Series Draper SK | 1001 | 18-21 | 4000-4200 |
| D-Series Draper SK | 1000 | 17-20 | 4000-4200 |
| D-Series Draper Dk | 1001 | 18-21 | 4000-4200 |

Project Impact

The proposed attachment poses no threat to MacDon's existing product line. The attachment will in and of itself increase the marketability of the M series windrowers. By creating mechanical shaft power through use of this attachment the M-series will be able to directly compete with 70HP tractors. In essence, this product has the potential to increase the appeal of MacDon's windrowers to a market that previously economically could not consider the M-series. This section discusses the economic impact for the select windrower market and outside risks that may be associated with the attachment.

Adding the attachment to the MacDon product line has liability issues that should be addressed. The main concern for MacDon and Missing link Engineering is the safety of this attachment for the operator, windrower, and attachable implements. Industry Standards for signage and hydraulic components such as mesh for the high pressure lines should be used. Additionally, pinch points should be taken into account in relation to the drawbar and PTO.

For hydraulic safety all connections must use the proper fittings and hoses that are rated over the operating pressure of 4000psi. The PTO will have a shield that meets ASABE standards. For all possible pinch points and safety risk areas there will be proper safety stickers illustrating the possible safety hazards. Additionally, to reduce the risk injury from pinch points, the operator's actions when interacting with the attachment were especially taken into consideration during design. This ranges from what is required of the operator to do during the connection of the attachment to the windrower to where the operator is supposed to stand while doing so.

From an economic standpoint this attachment has the potential to both save money for the producer and make MacDon's line of self-propelled windrowers more marketable. A 70 HP range tractor can cost anywhere from \$20000 to \$60000 depending on the brand, hours, and options installed. A used M155 windrower in decent condition can be purchased for \$60000 to \$100000 (tractorhouse.com). By marketing this attachment as the replacement for an extra tractor MacDon can economically justify the added value of a windrower for small operators.

Design Concepts

Drawbar

To lower manufacturing costs and processes it was decided that the drawbar for the attachment would be outsourced from another OEM. A drawbar from a John Deere tractor that's horsepower output places it in Category 2 was selected. A SolidWorks model of this drawbar is shown in Figure 12 below. This drawbar was also chosen for its short length of 578 mm. This minimized the size of the frame design.

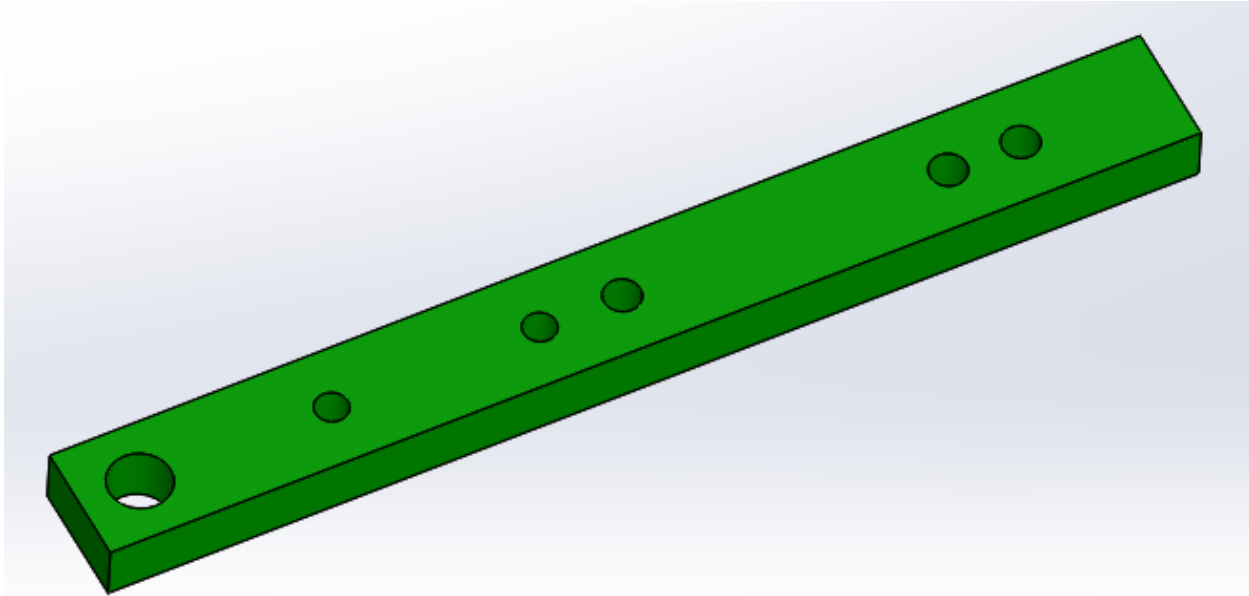

Figure 11: John Deere Category 2 Drawbar

Frame

The initial approach for designing the drawbar attachment was to use a 3-point hitch style design that utilized the windrower's header lift arms and center link as the connection points. After communicating with MacDon it was decided to use only the MacDon two header lift arms with mounting hardware used on MacDon's weight box. These attachments, or boots are shown below in Figure 12.

Before any designs were planned the dynamics of the tractor and baler as an assembly had to be calculated. The baler itself in the static position also had a set of calculations that needed to be performed.

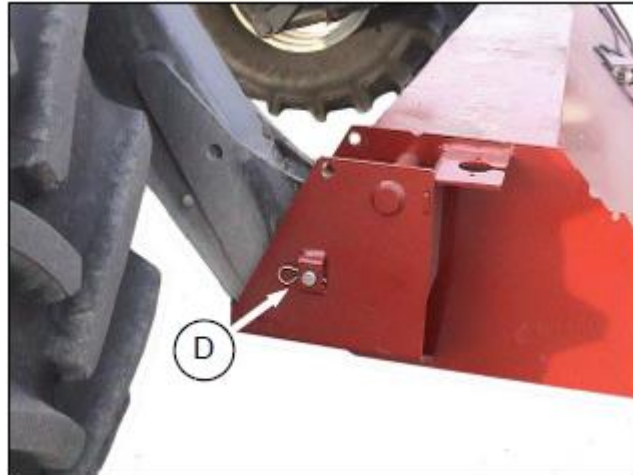

Figure 12: Side view of MacDon weight box from M155’s owner’s manual

The heaviest baler that was researched was a Vermeer 605 Super M. Its static weight was 8,300 lbs with a drawbar weight of 1,650 lbs and it produces a bale with an average weight of 2,400 lbs. With these forces in mind the basic static calculations were made to find the forces on the hitch with a full bale chamber. These values were computed with the assumption that when the bale chamber is full, the full weight of the bale is directly above the baler wheels. The equations used for these calculations are displayed in Equation set 4. These equations produced a resultant of zero vertical drawbar force with a full bale chamber. This is not always going to be true but gives a basis for design purposes.

Equation 4: Static force equations

$$\begin{aligned}\sum F_x &= 0 \\ \sum F_y &= 0 \\ \sum M &= 0\end{aligned}$$

Where

- $\sum F_x$ = sum of forces in the x direction (N)
- $\sum F_y$ = sum of forces in the y direction (N)
- $\sum M$ = sum of the moments about the baler wheels (N*m)

The dynamic conditions of this system consisted of estimating the force it takes to make the baler begin moving and also the vertical force the baler would exert on the drawbar at its maximum weight i.e. full bale chamber. While moving a baler with a full bale chamber is not typical, this situation was used because it simulated the worst case scenario for forces that would be exerted on the drawbar under field conditions. The calculations detailed below in Equation 5 were used to calculate this condition.

Equation 5: Force to begin moving a fully loaded implement

$$\sum F_x = \mu_s N$$

Where:

- μ_s = static coefficient of friction (unitless)
- N = normal force exerted on the wheels (N)

The equation above defined the force that it would take for the baler to start motion. In this case, the static coefficient of friction is used because the wheels are assumed to be rolling when pulling the baler rather than sliding. The force calculated to begin motion of the baler was 14094.5 N or 3,168 lbs.

For frame design the stress-life method was used. The initial calculations were done with the drawbar mounted in a pure bending situation. If, however, the drawbar was mounted in a position where the mounts are at a 45 degree angle this increased the strength of the drawbar and apparatus considerably in the bending moment. This process was modeled out in design for the stress-life method. Using this process involved designating a material and assuming an initial size as a starting point. This process included a set number of “k” factors which accounted for different variations in the material and hardware and are described in Equation 6. These factors include surface finish, profile of hardware, temperature, reliability, and a final miscellaneous factor.

Equation 6: Endurance limit

$$S_e = S_e' k_a k_b k_c k_d k_e k_f$$

Where:

- S_e = endurance strength (ksi)
- S_e' = endurance strength calculated from the ultimate strength (ksi)
- k_a = surface condition factor
- k_b = profile condition factor
- k_c = type of loading factor
- k_d = temperature factor
- k_e = reliability factor
- k_f = general “catch all” factor for any remaining conditions

This generated the stress values to find the safety factor. For these stress calculations the drawbar force was estimated. Then the stress was found that would be on the drawbar and attachment using Equation 7.

Equation 7: Bending stress

$$\sigma = \frac{Mc}{I}$$

Where

- σ = bending stress (ksi)
- M = bending moment (N*m)
- c = radius of profile (m)
- I = second moment of area (m⁴)

Using Equation 7 it was estimated to have produced a stress of 57.95 MPa for pure bending and 11.03 MPa in partial bending and partial shear.

After solving for the initial safety factor, the safety factor determined whether the size of the materials used was adequate. With the initial assumption of square tubing with dimensions of 6"x6" and .25" wall thickness, it was determined that the safety factor was not enough to be able to sustain usage in the field. The second iteration used 8"x8"x.25" wall thickness which resulted in a safety factor of 2.43 in pure bending conditions and a safety factor of 12.78 in partial bending and partial shear conditions. This result was conclusive that the triangular drawbar mount was the best option with the square window frame. Tables in the appendix show the calculations behind these assertions.

The initial design from the fall semester or "Mule" included a 3-point mounting concept that would attach at the points of connection on the windrower. Figure 14 shows the final fall design. It featured a window frame with connection points at the top, and on the sides. Slot and tab design concepts were used on the back of the drawbar mount to add strength and stability.

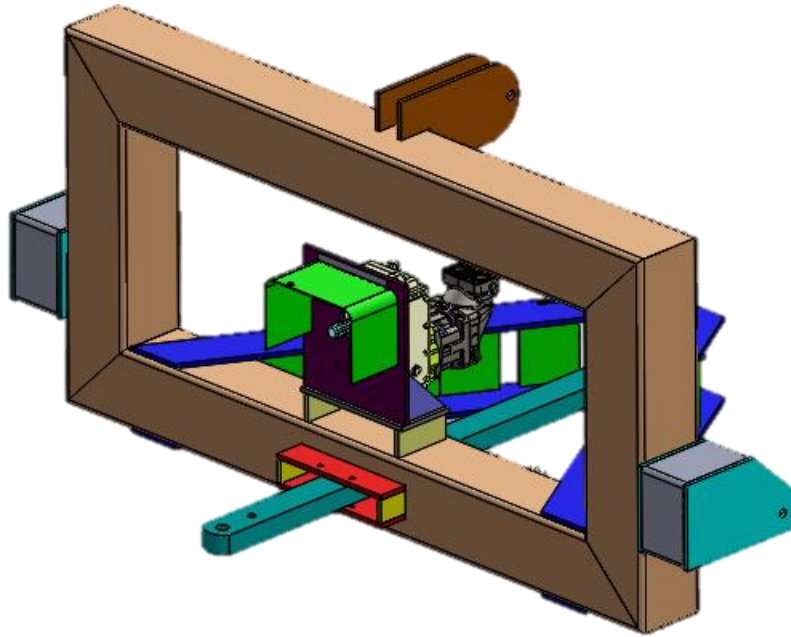

Figure 13: Square frame, plate mounting

Figure 15 shows the redesigned version of the original design. Instead of using the top center link as a support, this has been eliminated and only used the two side boots that fit over the windrower's lifting arms are used. The PTO mounting plate has also been redesigned to be manufactured from a single plate of steel. The holes in the top of the frame itself are access ports to be able to access the inside of the frame to disconnect the PTO mount from the frame. For added strength and support, two gussets have been added on either side of the boot mounts for added strength and support. Skid legs have been added to keep the attachment at the proper height for mounting to the windrower and to keep it off the ground when not being used.

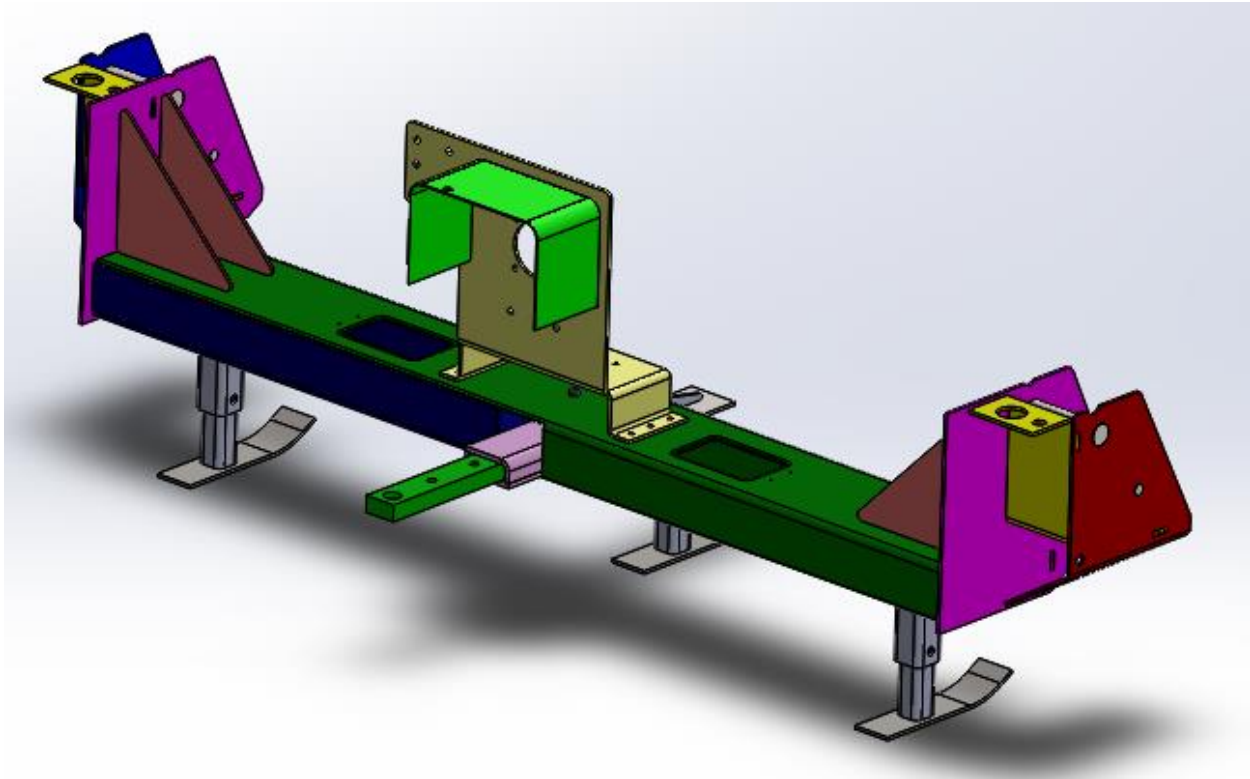

Figure 14: Redesigned Mule Frame

Figures 16 and 17, show the left and right side of the new redesigned frame. The mounting boots seen are the mounts from MacDon weight box. These mounts have been trimmed down of excess material. By using predesigned boots from MacDon, this allows easier transition for MacDon to produce the new stream lined boots.

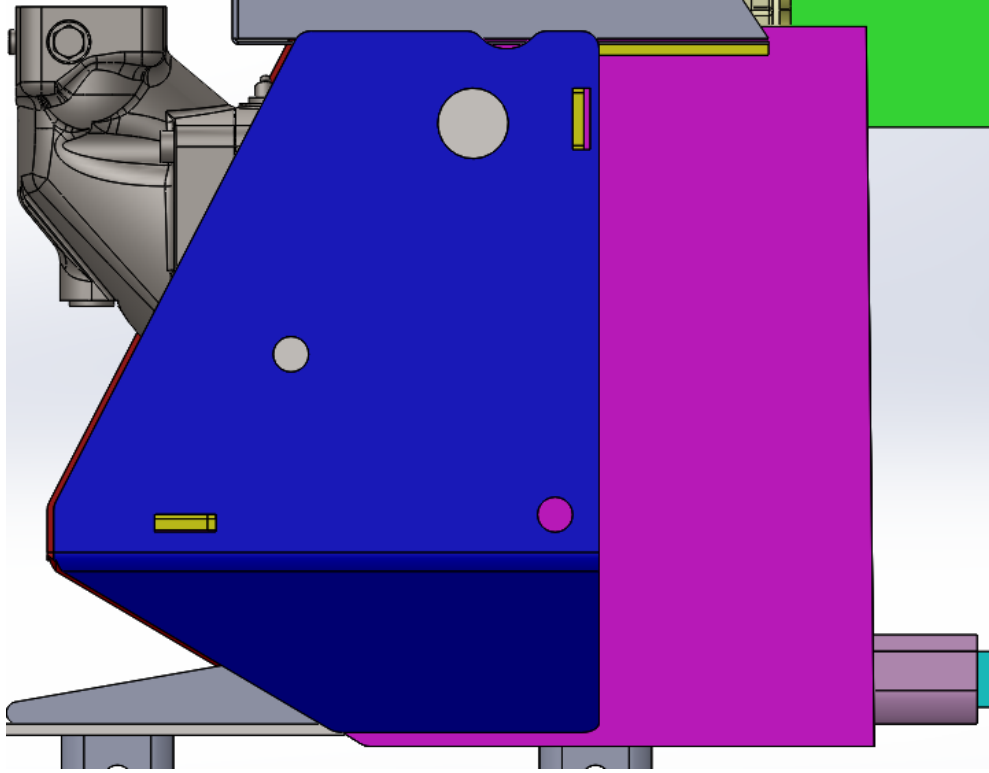

Figure 15: Left Side Boot

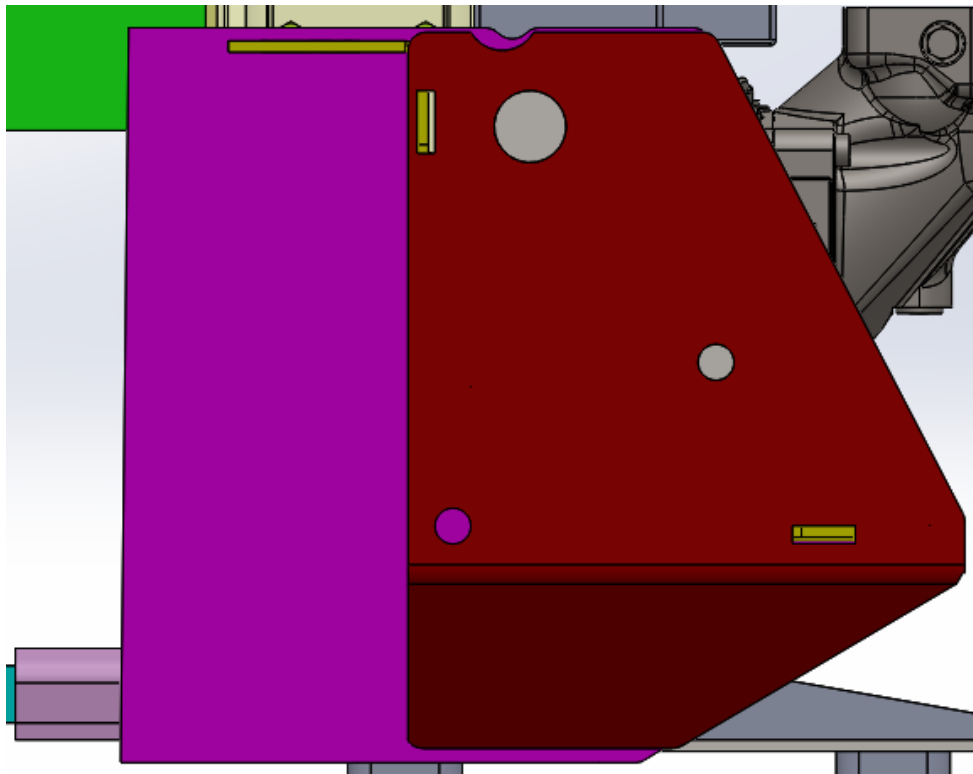

Figure 16: Right Side Boot

Unlike the fall semester design, more components were designed to have higher manufacturability. The main frame members, seen in Figure 18, are formed from two structurally identical plates of 1/4" steel plate rather than tubing seen in Figure 14. Both plates have a hole for the drawbar pin to insert through. The top plate has mounting holes for the gearbox mount and access ports, Figure 19, to allow for the attachment of the gearbox mounts. These can be covered at later time with doors to prevent debris buildup inside of the frame.

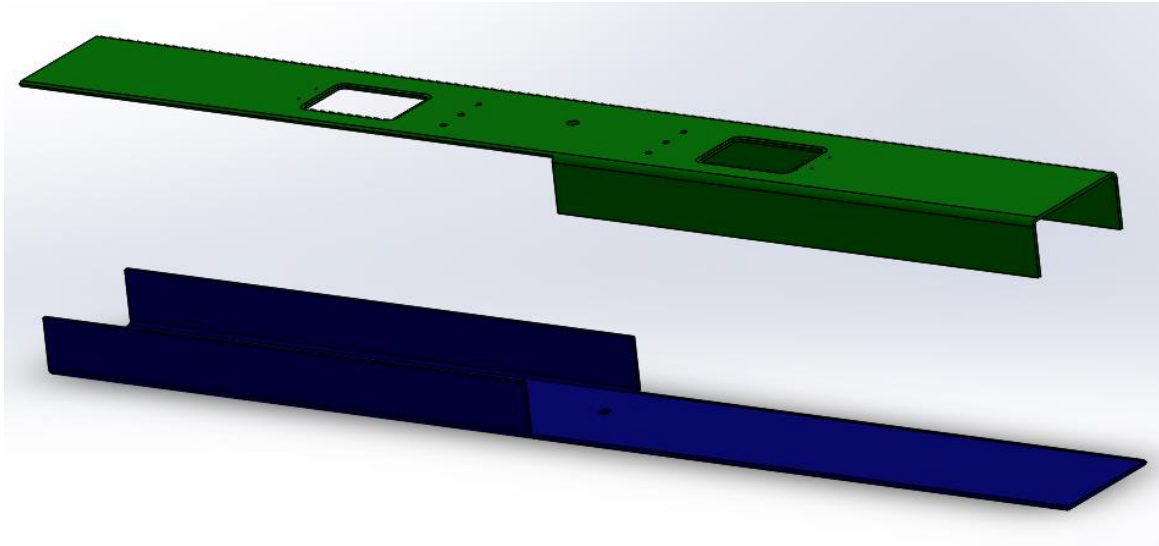

Figure 17: Two Piece Frame Members

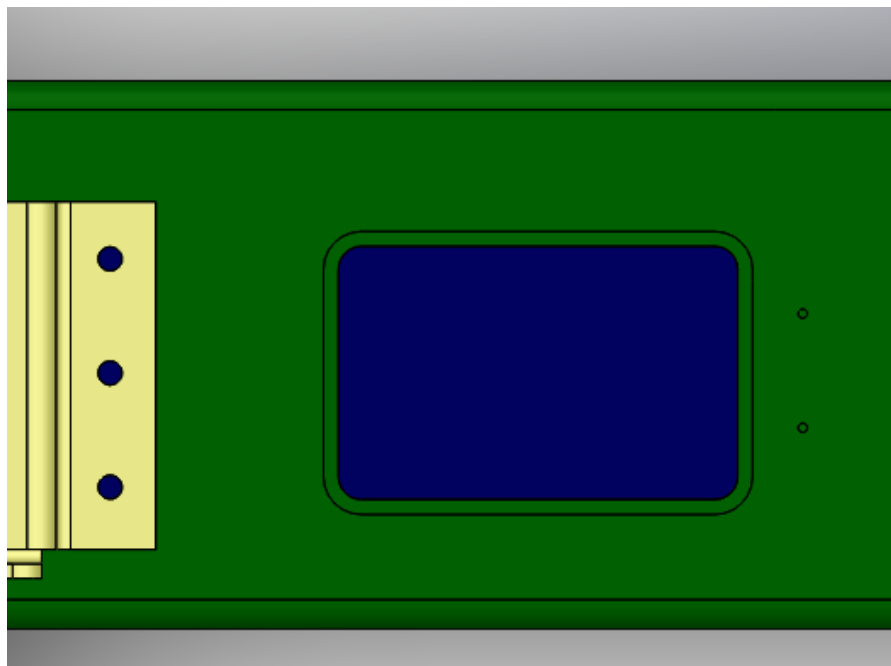

Figure 18: Access Port

An FEA analysis was performed on the drawbar alone and it was determined that the pin holding the drawbar in place was not strong enough to withstand the 15,000 N load applied to the

front of the drawbar as calculated earlier. To address this issue housing that surrounds the drawbar was added. The housing is made out of 3/8" plate, and adds strength and structure to the drawbar and the pin hold the drawbar in place. This housing also keeps the drawbar stationary during field conditions. It is shown below in Figure 20 in pink.

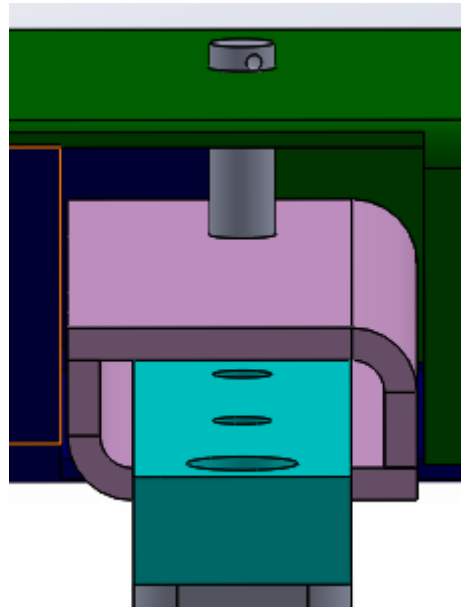

Figure 19: Drawbar Housing

Shown in Figure 21 are skids that the attachment sits on when not attached to the windrower. Three skids were added to the bottom of the frame to raise the frame to the proper height for mounting the Mule onto a windrower. It also keeps the bottom of the frame off the ground and to makes all of the components on the mule easier to access for the operator. The skids mounted on the bottom side are 305 mm in length. This gives the operator better mounting ability when attaching the mule to the windrower. Being raised off the ground, it is less susceptible to rust and decay from moisture on the ground. The feet of the skids have a curved design allowing them to not interfere with windrows or other obstacles in the field. These skids are also designed with two positions, which are changed by removing a pin and sliding the skids up or down. Field mode, is when the skids are raised to their highest position, being out of the way of the windrows. Stationary mode, is when the skids are lowered allowing the frame to have maximum height off of the ground.

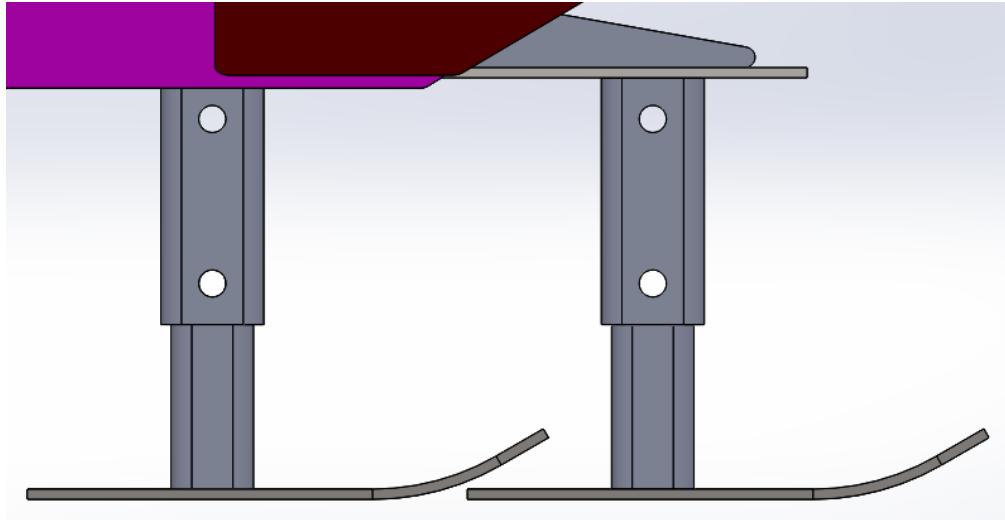

Figure 20: Side View of Support Skids

To lower torsional stress between the main frame of the attachment and the mounting boots, triangular gusset plates were mounted at the meeting point of the two members. These were implemented on both sides and attachment and can be seen in Figure 22.

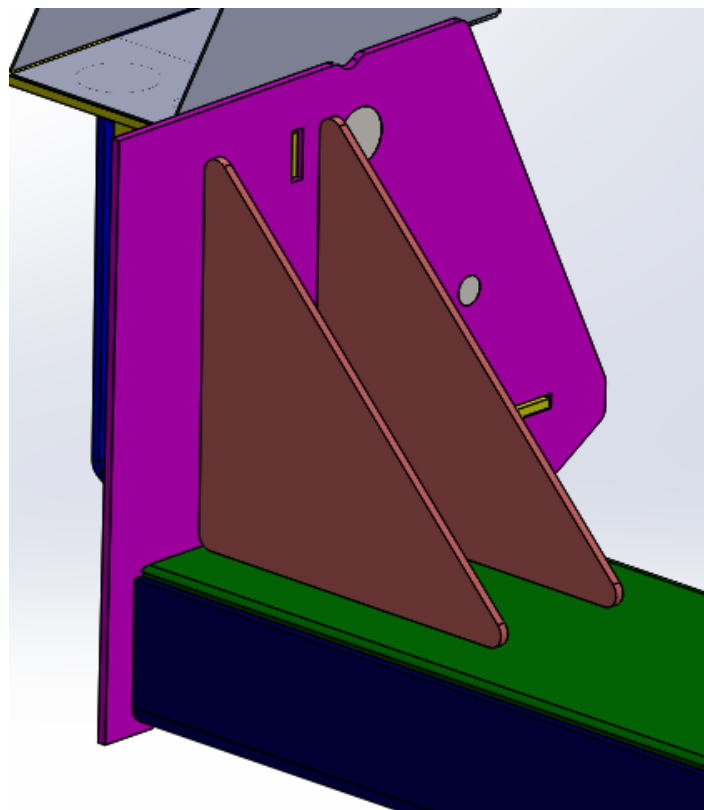

Figure 21: Anti-Torsion Gussets

Stress and displacement analysis was conducted on the main frame. A force of 890 N was applied across the whole face of the PTO mount. This was to account for the weight of the PTO

and gearbox. 15,000 N was applied on the drawbar to simulate a pulling force from a baler. This force was more than any force found when doing research of different balers throughout the industry. A torque of 136 N*m was also applied on the front face of the PTO mount to simulate the torque the PTO would create. The points of fixture for this simulation was the top welded bar on each boot and the bottom pin on the boots. As seen in Figure 23 there was very minimal stress on the design as a whole. The most stress was on the bottom part of the frame, under the drawbar. This was expected since this is where most of the forced occurs, but still very minimal. Displacement analysis on the mule is shown below in Figure 24, this was also minimal, the most displacement occurred in the center of the Mule on the PTO mount and drawbar. This also was expected being this is the center of most of the forces.

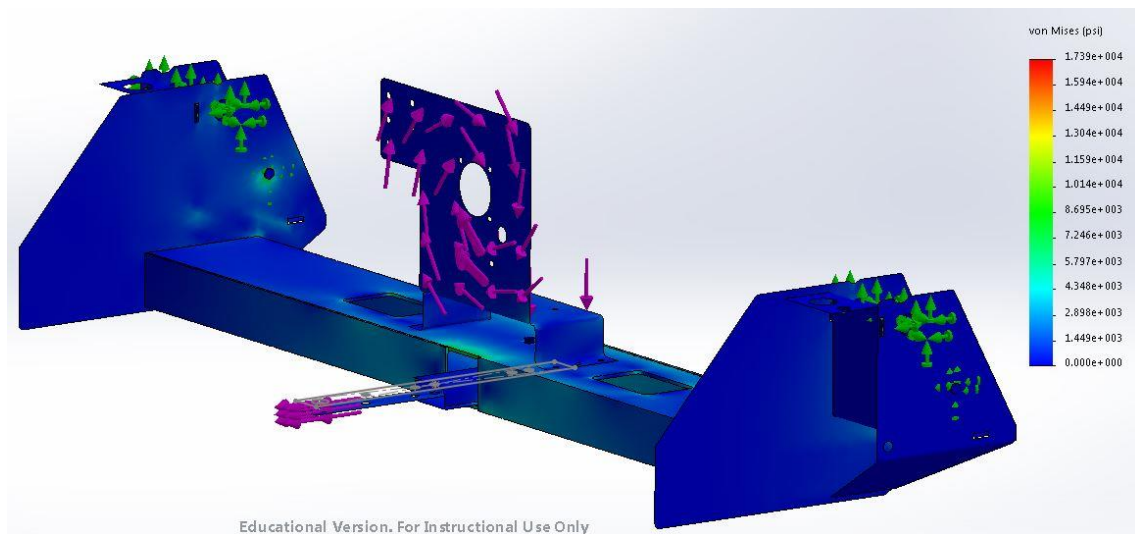

Figure 22: Frame Stress Analysis

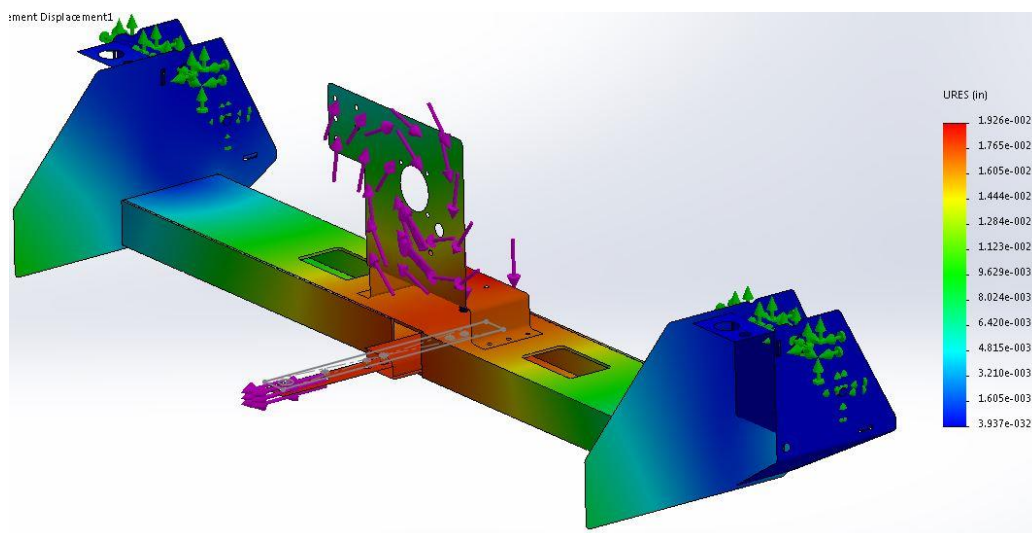

Figure 23: Displacement Analysis

Hydraulic Circuit

The PTO will be powered using a bent axis piston hydraulic motor. MacDon has previously used similar designs on its pull type rotary headers. The 2012 and prior R85 13ft model made use of a Parker Hannifin hydraulic motor and a Comer gearbox in order to convert the tractor PTO mechanical power to hydraulic power, which was then run to the rotary. This system was designed for a 540 rpm PTO shaft. Making use of a similar concept and a 540 rpm shaft, the system can be used for our attachment design. The Parker Hannifin motor can operate over a variety of speeds and by varying the windrower controls to a calibrated point which will increase load in order to meet the horsepower needed. Figure 25 is the Parker Hannifin F12-80 motor with Figure 26 showing the associated Comer A640 gearbox. The performance curve for the pump is displayed in Figure 27. The F12 series pump has a performance above 90% efficiency over the entire range the motor would be operated.

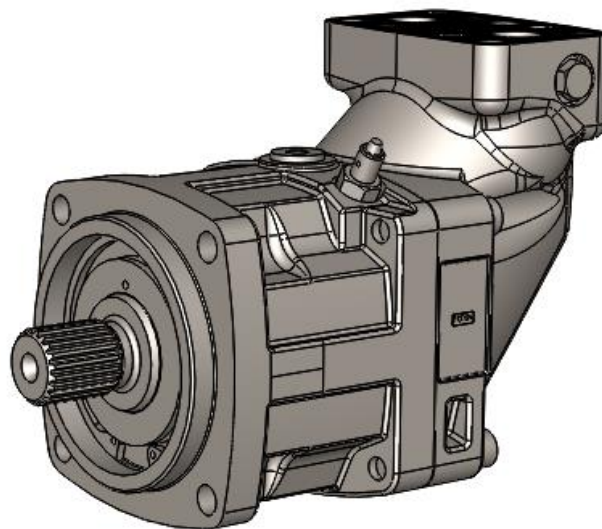

Figure 24: Parker Hannifin Pump Model

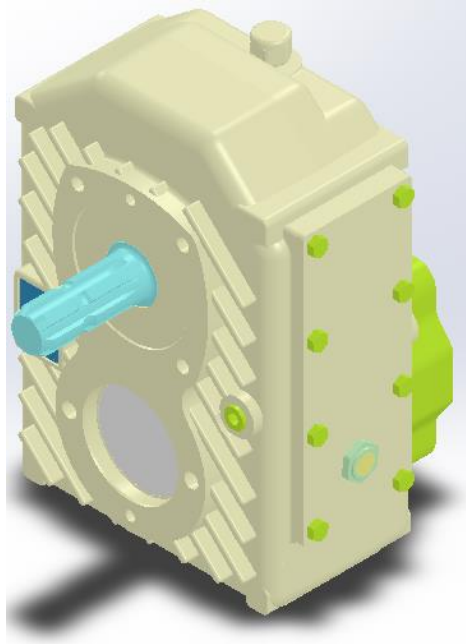

Figure 25: Comer A640 Gearbox

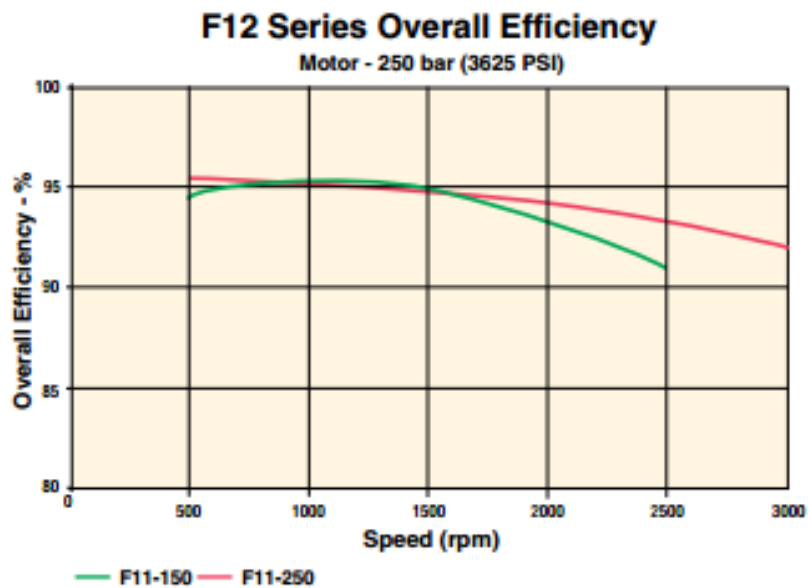

Figure 26: Parker Hannifin Pump Operation Speed

The predicted power generation from the motor and gearbox came from use of Equation 8. Values for each circuit including available flowrate and pressure were gathered from MacDon’s Technical Manual for an M155 Self Propelled Windrower. The available horsepower in Table 8 exceeds the minimum design value of 70 determined in the technical requirements section. The Comer gearbox from MacDon currently has a gear ratio of 1:2. The motor rpm to

output rpm would be double using this setup. This translates to an available horsepower of 53.3 as shown in Table 9. While this is below the design criteria, testing can be completed using this gear ratio and scaling to a 3:1 gearbox reduction can occur.

Equation 8: Equation for hydraulic horsepower

$$HP = \frac{Q * P}{1714}$$

Where:

- HP = Horsepower generated (hp)
- Q = hydraulic flowrate (gpm)
- P = pressure (psi)

Table 8: Available Power

| Drive Hydraulic Power | | | |
|------------------------------|-----------------------|-----------------------|-----------|
| Pump | Flowrate (gpm) | Pressure (psi) | HP |
| Knife | 27 | 4000 | 63 |
| Draper | 15 | 4000 | 35 |
| | | Theoretical | 98 |

Table 9: Available Power Using a 2:1 Gearing

| Variable | Value | Unit |
|-----------------|--------------|-------------|
| Displacement | 80 | cc/rev |
| Pressure | 4000 | psi |
| Speed | 540 | rpm |
| Gear Ratio | 2:1 | |
| Flowrate | 22.8 | gpm |
| Power | 53.3 | HP |

Table 10 shows the predicted horsepower using a 3:1 reduction. The value of 80HP exceeds the design criteria as long as the efficiency of the system stays above 88%. This efficiency can be achieved using the existing setup as long as pressure losses in the piping system are not egregious. In order to simulate a 3:1 reduction, the existing setup can be run at 810rpm which would allow the motor to displace the same fluid flowrate and generate the subsequent power.

Table 10: Available Power Using a 3:1 Gearing

| Variable | Value | Unit |
|--------------|-------------|-----------|
| Displacement | 80 | cc/rev |
| Pressure | 4000 | psi |
| Speed | 540 | rpm |
| Gear Ratio | 3:1 | |
| Flowrate | 34.2 | gpm |
| Power | 79.9 | HP |

Figure 28 shows the proposed circuit for the windrower attachment. The draper and knife circuits will be used for PTO power. The auxiliary block and DWA block will be used in tandem with the Multifunction Control Block to power the outlets. A few things to note in the circuit are the check valves used upstream of a hydraulic manifold. Also, the single point connection will be used for one of the single acting and one of the dual acting circuits for the outlets.

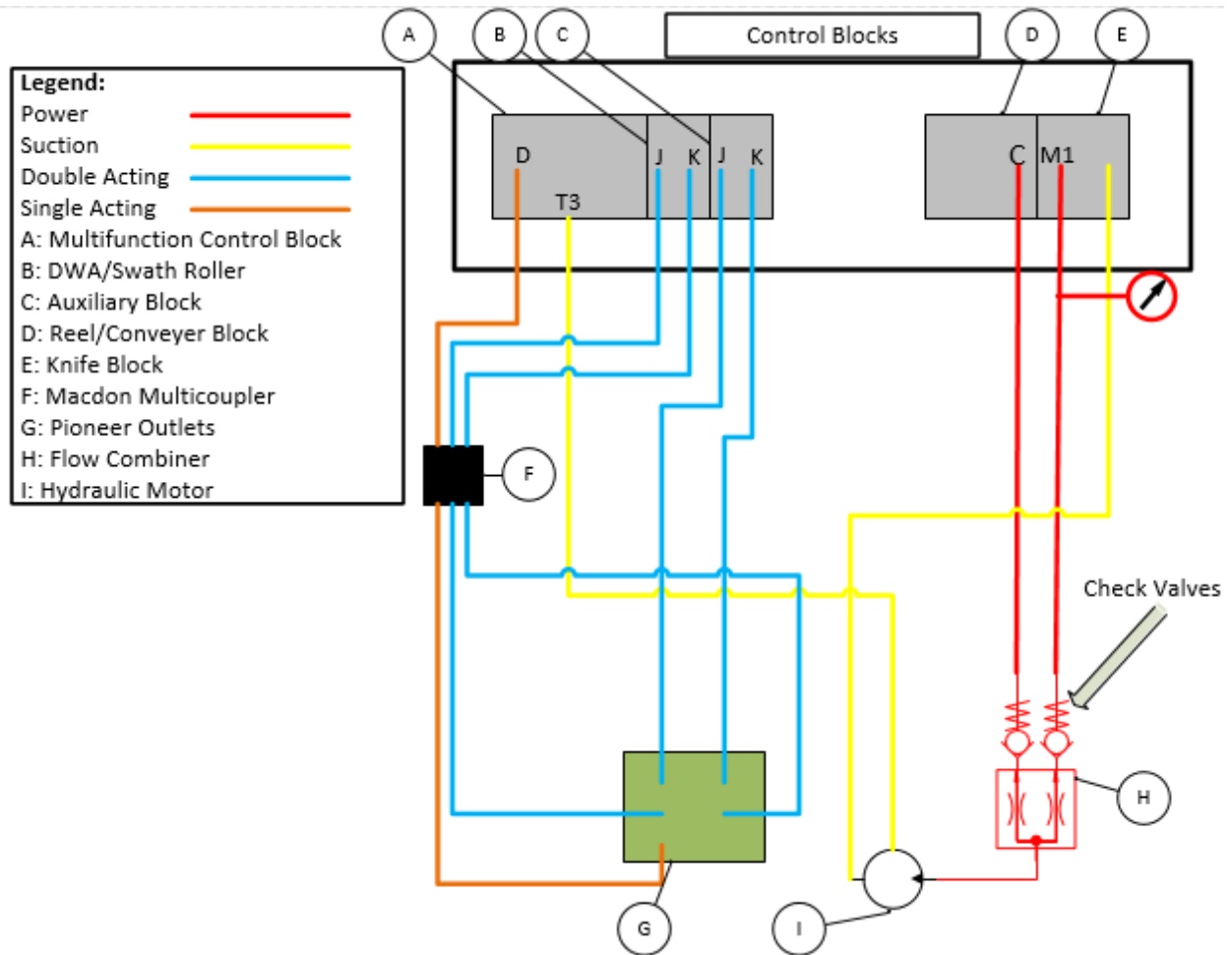

Figure 27: Hydraulic Circuit

Flow Combination Manifold

A manifold, Figure 29, was designed to combine the knife and draper circuits from the windrower. This manifold was designed from 6061-T6 aluminum so that it would be easy to machine and strong enough to withstand the working pressures of the system. The manifold was designed with a factor of safety of 4 using Equation 9. By solving for the outer radius of the pressurized cylinder, the outer thicknesses of the manifold were determined. An FEA analysis was then run using SolidWorks to verify the integrity of the manifold as seen in Figure 30.

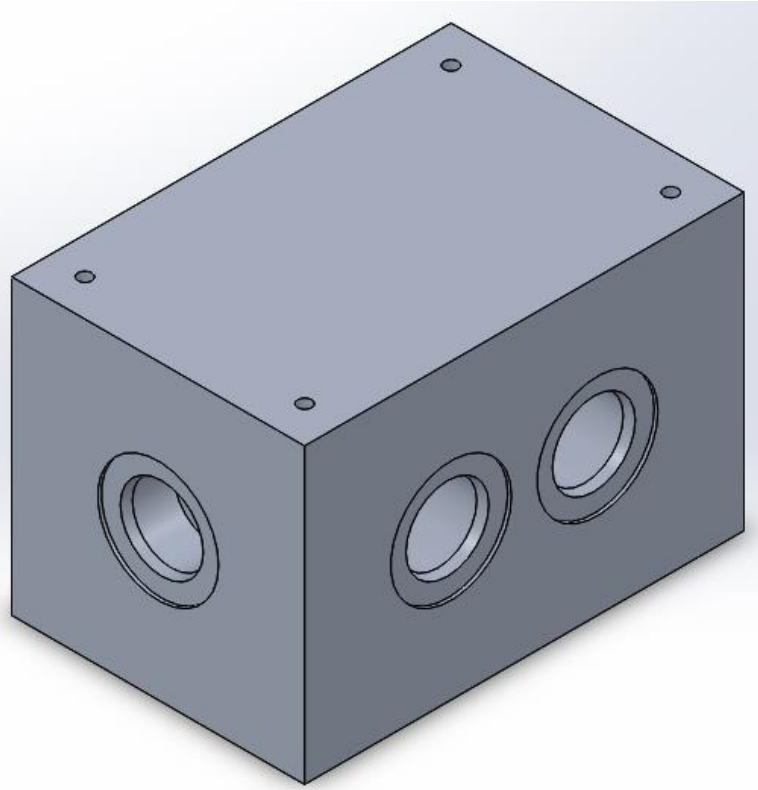

Figure 28: Hydraulic Manifold

Equation 9: Tangential Stress in a Pressurized Cylinder

$$\sigma_{max} = \frac{r_i^2 * p_i}{r_o^2 - r_i^2} * \left(1 + \frac{r_o^2}{r_i^2} \right)$$

Where:

- σ_{max} = the maximum hoop stress developed in the pressure vessel
- r_i = the inner diameter
- r_o = the outside diameter
- p_i = the internal pressure of the pressure vessel

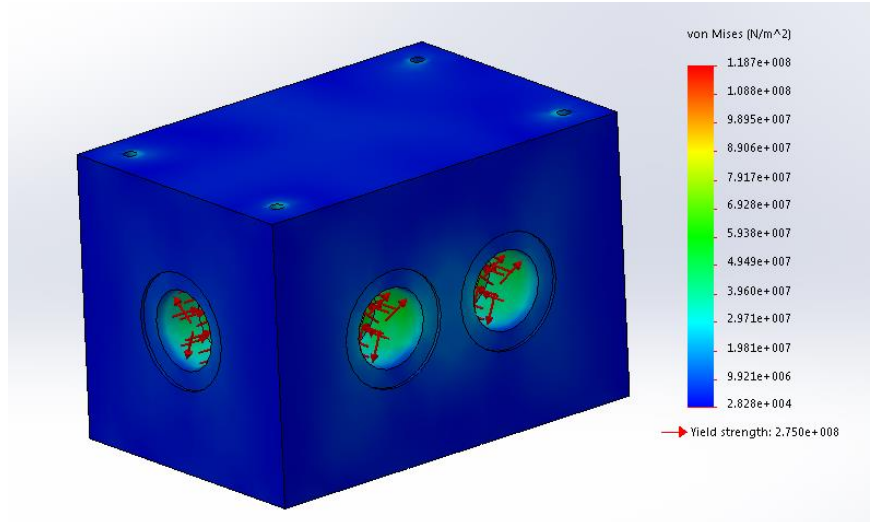

Figure 29: Manifold Static FEA with 4000 psi

Figure 31 below shows the flow characteristics of the manifold. The cross hole was drilled into the manifold on the right side to give a corridor for the two incoming flowrates to combine and then exit the single port. The hole was then capped off. All ports of the manifold were designed for 3/4" O-ring boss fittings.

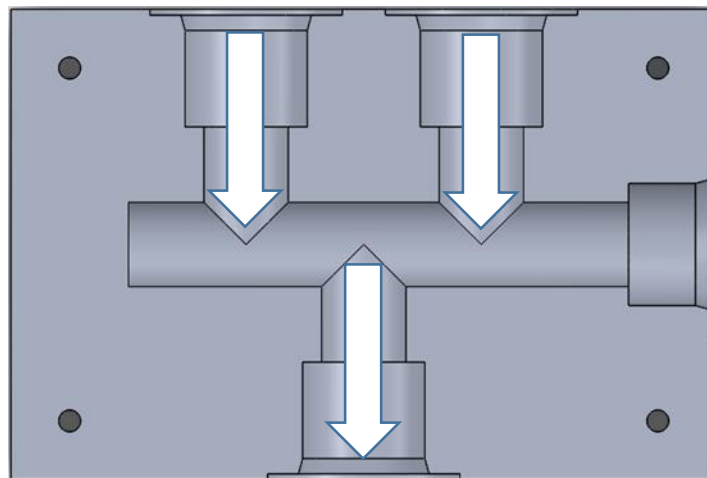

Figure 30: Manifold Flow Combination Illustration

To prevent backflow into either circuit if the pressures are not properly normalized to the same working pressures, two check valves were placed into the circuit before being combined in the manifold. Stucchi check valves seen in Figure 32 were selected to minimize costs. V34 check valves were selected for this application because their technical specifications, seen in Table 11, met all design criteria.



Figure 31: Stucchi Check Valves

Table 11: Stucchi Check Valve Specifications

| DESCRIPTION | SIZE | MAX SUGGESTED FLOW | | MAX OPERATING PRESSURE | | BURST PRESSURE | |
|-------------|-------|--------------------|--------|------------------------|------|----------------|-------|
| | Inch | l/min | GPM | MPa | psi | MPa | psi |
| VU18 | 1/8 | 6 | 1.59 | 40 | 5800 | 160 | 23200 |
| VU14 | 1/4 | 24 | 6.36 | 35 | 5075 | 140 | 20300 |
| VU38 | 3/8 | 46 | 12.19 | 35 | 5075 | 140 | 20300 |
| VU12 | 1/2 | 90 | 23.85 | 30 | 4350 | 120 | 17400 |
| VU34 | 3/4 | 148 | 39.22 | 30 | 4350 | 120 | 17400 |
| VU100 | 1 | 200 | 53 | 30 | 4350 | 120 | 17400 |
| VU114 | 1 1/4 | 378 | 100.17 | 25 | 3625 | 100 | 14500 |
| VU112 | 1 1/2 | 600 | 159 | 25 | 3625 | 100 | 14500 |
| VU200 | 2 | 1000 | 265 | 15 | 2175 | 45 | 6525 |

TEMPERATURE RANGE: FROM -20 °C (-4 °F) TO 120 °C (248 °F)

Mounting

The PTO gearbox that was chosen for the attachment has to be properly mounted and secured while still being serviceable. To improve the design from the fall semester the mount was designed using a single sheet of steel that could be laser cut and bent into the proper shape. Figure 33 shows the concept developed for mounting the PTO gearbox. The mount will be bolted to the main frame of the attachment directly above the drawbar. This mount uses six bolts to attach it to top of the main frame from the tabs on the sides of the mount. The front plate has 6 holes to use the mounting holes of the front of the gearbox. The 5 holes on the left hand side to allow for mounting of the Pioneer outlets. This will place the outlets within the envelope described in ANSI/ASAE S366.2 May 2004. A hole was be cut in the right side of the front of the plate to allow for access to an oil fill port on the front of the gearbox. The face of the plate is wide enough to allow for proper attachment of a PTO shield.

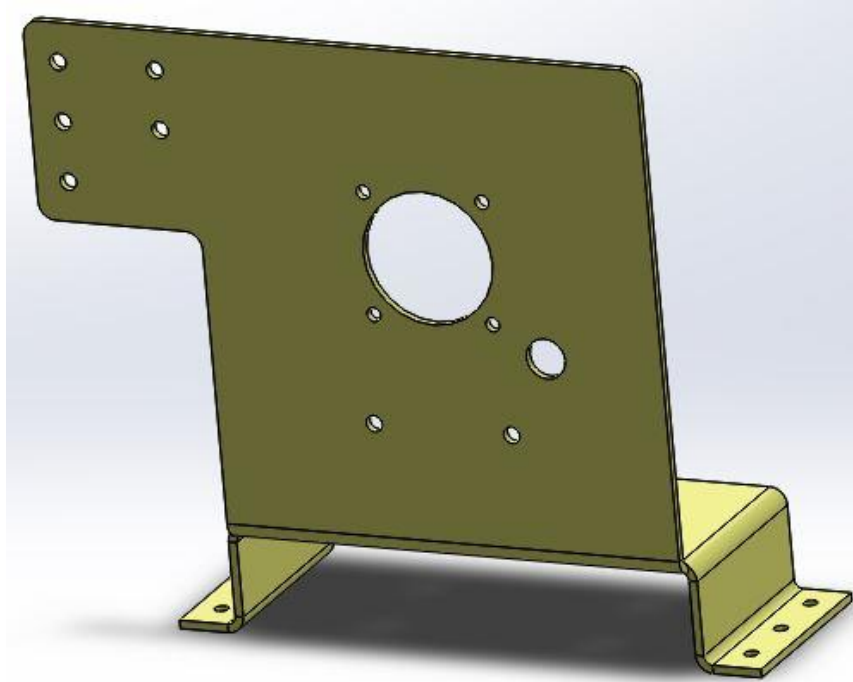

Figure 32: PTO Mount

Figure 34 shows the bottom side of the PTO mount. The mount is 76 mm tall to allow for adequate room to both insert bolts from below and fit a socket under the plate to tighten them. This height also ensures that the PTO is at the proper height above the drawbar as per ASABE standards.

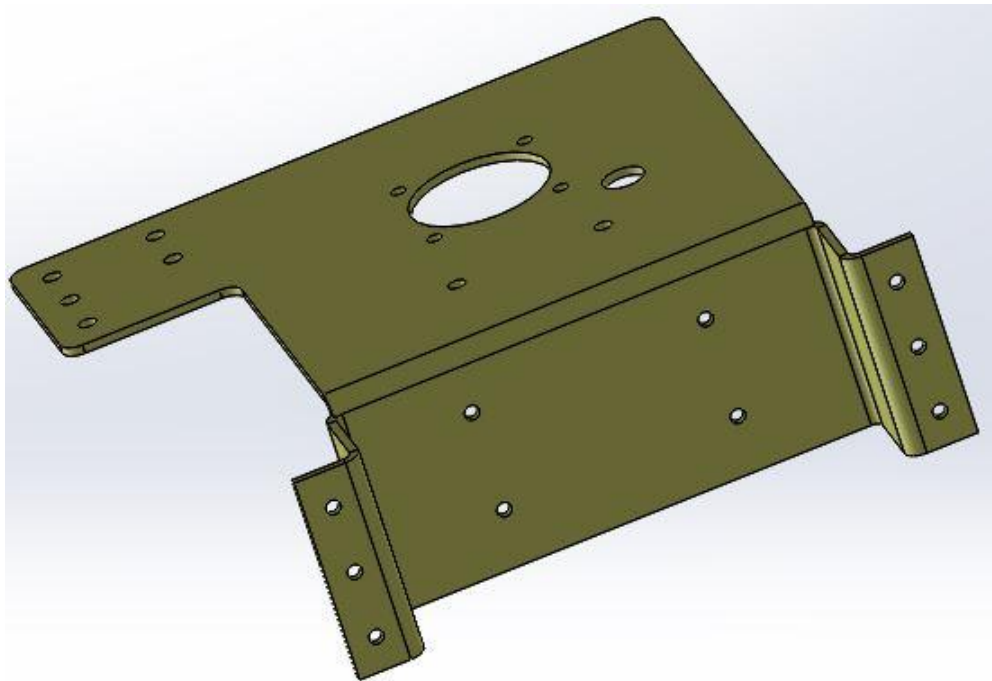

Figure 33: PTO Mount Bottom View

The hydraulic multicoupler mount is shown mounted below in Figure 35. This mount is made out of a single piece of 1/16” sheet. Being made out of a single piece, this mount is very easily manufactured, requiring only bends and welds. The hydraulic connector rests on the very top being screwed into the mount. It needed to be up off the frame itself so they could be easily connected to the hydraulic outlets on the windrower. By doing this it allows ease of attaching and detaching the hydraulics.

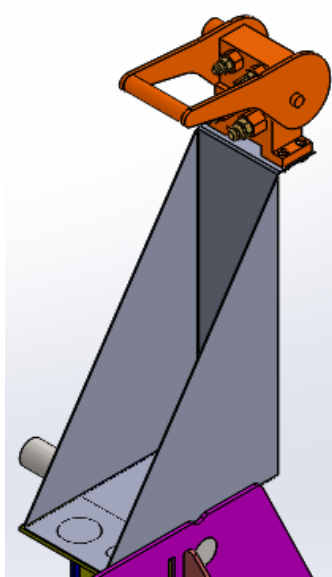

Figure 34: Single Point Hydraulic Mount

The hydraulic manifold also needed a place to mount on the frame. Figure 36 shows this mount below. Like the hydraulic coupler mount, it is fabricated out of a single piece of sheet steel, which is then bent and welded to the frame. The manifold needed to be mounted in the center of the mount so the hydraulic connection at the bottom had enough room. Four bolts hold the manifold in place in the mount ensuring that it will be sturdy.

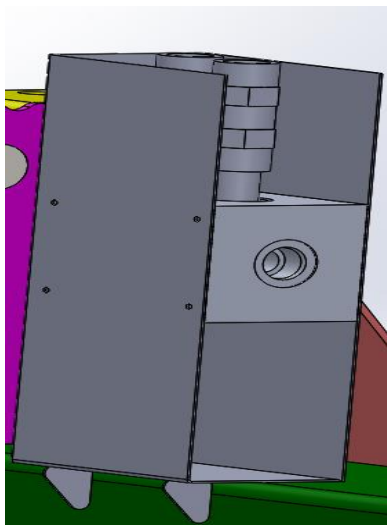

Figure 35: Hydraulic Manifold Mount

Wiring and Speed Sensor

To make the windrower read the correct header code a wiring harness with the properly energized pins had to be utilized. Figure 37 below displays the header connection wiring diagram for the wiring harness. A wiring harness for MacDon’s weight box was acquired to give a connection for trailer wiring, Figure 38, and to allow for wiring of the header code. To make the windrower’s computer read the proper code of 0100, pin H.

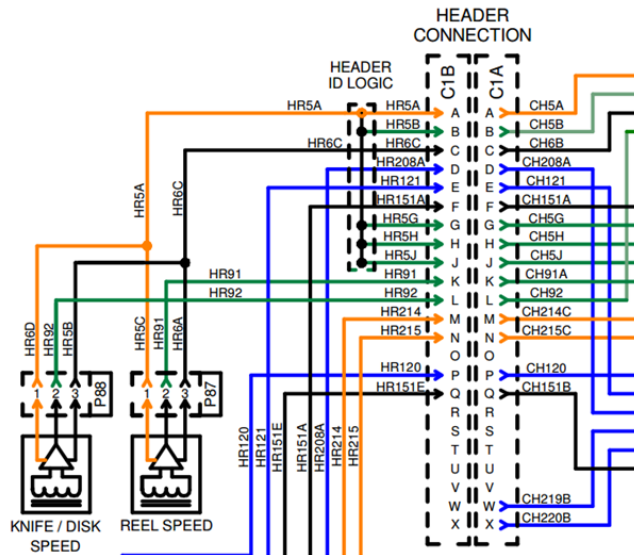

Figure 36: Header ID Wiring Diagram M155



Figure 37: Trailer Wiring Connection

In order to give the operator a live read out of the rotational speed of the PTO in RPM, a speed sensor needed to be implemented into the design. This will allow the user to both set the RPM for their application and make adjustments if they heavily load down the system. The most appealing sensor option was to use the Hall Effect sensor labeled “6” in Figure 39 below. This sensor is used in MacDon’s existing designs and is used to relay important speeds to operator

like the Disc, Knife, and Reel speed. It normally operates 2 mm away from a pulley that has 3 notches cut out of its back face. When this pulley spins the sensor picks up the breaks in its magnetic field and the windrower's programming registers a revelation that it displays as RPM depending on settings.

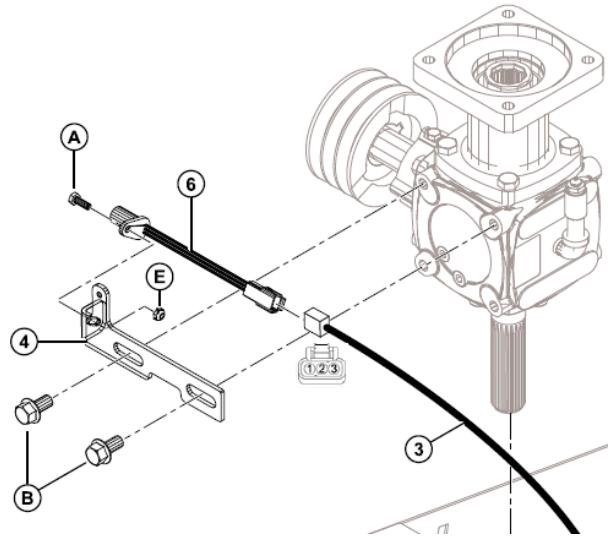

Figure 38: Speed Sensor from R85 Header

The sensor pickup was design was emulated on the attachment. As seen in Figure 40 below a plate was attached to the PTO shaft with a lock collar. This plate has 3 notches cut from it that pass in front of the sensor mounted in the upper right hand corner of the PTO mount. The sensor was wired into pins A, C, and K to make the CDM readout the PTO's RPM as the Knife/Disk Speed.

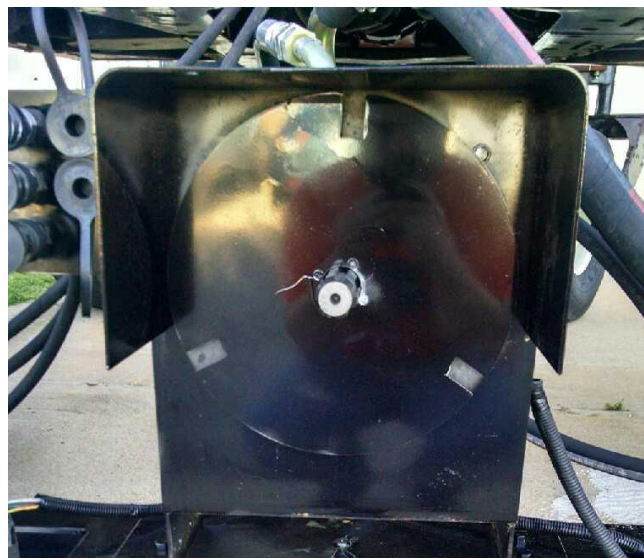

Figure 39: Speed Sensor Pickup

Operation

The attachment has to be designed for ease of use to make the transition from using a windrowing header to pulling an implement effortless for the operator. When operating the attachment, this will be achieved by using the same buttons as during normal windrowing. The header engage/disengage switch in Figure 41 will be used to engage and disengage the PTO drive of the attachment. The hydraulic bank will be activated using the joystick controls as was pointed out in Figure 6.



Figure 40: Header Engage/Disengage Switch from M155 operator's manual

Connecting hydraulics for both the hydraulic bank and powering the PTO will be made easy by the use of the hydraulic couplings points used on the D65 header as seen in Figures 42, 43, and 44.

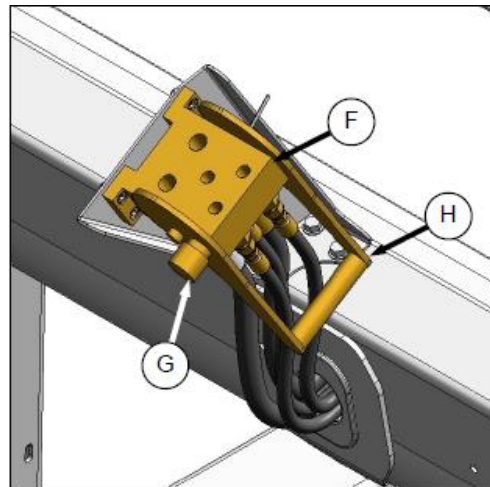

Figure 41: Auxiliary hydraulic coupling plate from D65 owner's manual

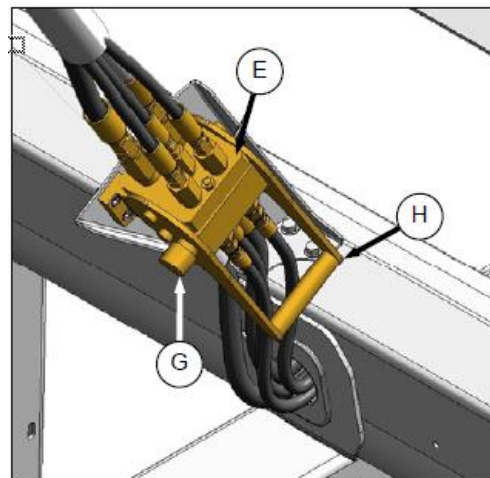

Figure 42: Auxiliary hydraulics attached to coupling plate from D65 owner's manual

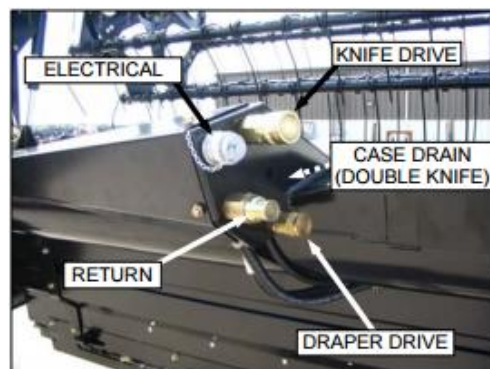

Figure 43: Knife and Draper Hydraulic Connection points PTO power from D65 owner's manual

The connection on the right side is MacDon's assembly B5457 that consists of a block valve that the hydraulic hoses from the right side of the windrower latch onto with a handle.

Hoses will then run to the plate that is the mounting plate for the gearbox. These will attach to the Pioneer quick coupler.

Figure 46 shows the type of Pioneer quick coupler used in the attachment. The couplers use half inch pipe thread fittings. The suggested operating pressure is within the bounds of our design (4300psi). These couplers have O-ring seal sleeve-lock sockets. All hydraulic lines are high-pressure reinforced-rubber hose.



Figure 44: Pioneer quick coupler from McMaster-Carr

In order for the attachment to run while in engine forward mode, the windrower must first be adjusted at several key operating points. First, the pressure on both the reel and draper drives should be adjusted to 4300psi. This can be accomplished using the testing protocol set forth in the M155 owner's manual. The engine will need to run in the upper half of its operating speed in order to power the drive for both the reel and knife drive pumps.

The steps to take a normal M155 windrower configured to run a draper header from operating a header to running the Mule, in its current configuration are:

1. Pick up the attachment with the lower lift arms and set them down onto hydraulic stops. This is the same operating position of MacDon's weight box.
2. Pressure and relief setting must be adjusted up for the draper's pump so that they meet those of the knife circuit.
3. Hoses with couplers must be connected and routed from the DWA hydraulic block to the front of the cab of the windrower.
4. Header controls must be adjusted in the CDM setup menu based on the application.
5. Hydraulic and electrical connections are made exactly like they are on a normal header with the exception being those from the DWA block.

Safety

Safety was of the utmost importance in our design. Both for the manufacturing processes and operating procedures. Most pieces of agricultural equipment are considered inherently dangerous. With this in mind, the overall safety and reducing overall risk for the operator.

Hydraulic Safety

Hydraulic lines contain high pressure fluid that can be detrimental to operators if breaks or pinching occurs in lines. If a leak is found, operators under no circumstances should run any of their appendages over the line to find the leak. A common practice is to use cardboard, or some other material, to shield oneself and to find potential leaks. Proper safety labels should be placed on all lines and around connections on the implement in order to insure operator safety.

PTO Safety

The attachment will feature a 540 PTO shaft. According to farminjuryresource.com, “most PTO accidents occur when the PTO shaft is rotating at slower speeds.” PTO accidents can be caused by a wide range of issues but primarily occur due to some form of operator error. The main risk comes from an operator becoming entangled in either the shaft or directly with the PTO stub shaft. [Farminjuryresource.com](http://farminjuryresource.com) makes it quite clear that “designers and manufacturers of farm machinery have an obligation to make sure their products are as safe as possible.” This means the responsibility of ensuring the attachment is as safe as possible falls on us as the designers.

We must ensure our attachment has a proper PTO master shield. Guidelines for the geometry of a master shield are laid out in ASABE/ISO 500-1 along with the statement that “If the PTO master shield can be used as a step, it shall withstand a vertical static load of 1200 N without permanent deformation.” This load of 1200 N is equivalent to roughly 270 lbf. OSHA regulation 1928.57(b)(1) states that a PTO master shield “shall have sufficient strength to prevent permanent deformation of the shield when a 250 pound operator mounts or dismounts the tractor using the shield as a step.” For design purposes, we will use the values of 1200 N across the top surface of the shield and iterate with various thicknesses to design a proper shield. We constructed a shield model in SolidWorks from ASABE/ISO 500-1 with dimensions and geometry from Table 9 and Figure 13 and iterated the various sheet metal sizes MacDon told us we could use i.e. 7, 11, 14, and 16 gauge steel. Models were fixed along the back of the shield. Fixtures are represented by the green arrows in Figure 43. The 1200 N load was applied across the entire top of the model and is represented by the purple arrows in Figures 47 and 48. The first model to not fail was one made of 11 gauge A36 steel and produced a factor of safety of 2.77, which meets MacDon’s parameters. This was calculated using Equation 10.

Equation 10: Static factor of safety

$$n = \frac{S_y}{S}$$

Where:

- n = factor of safety
- S_y = yield strength of the material (psi)
- S = stress developed in the member (psi)

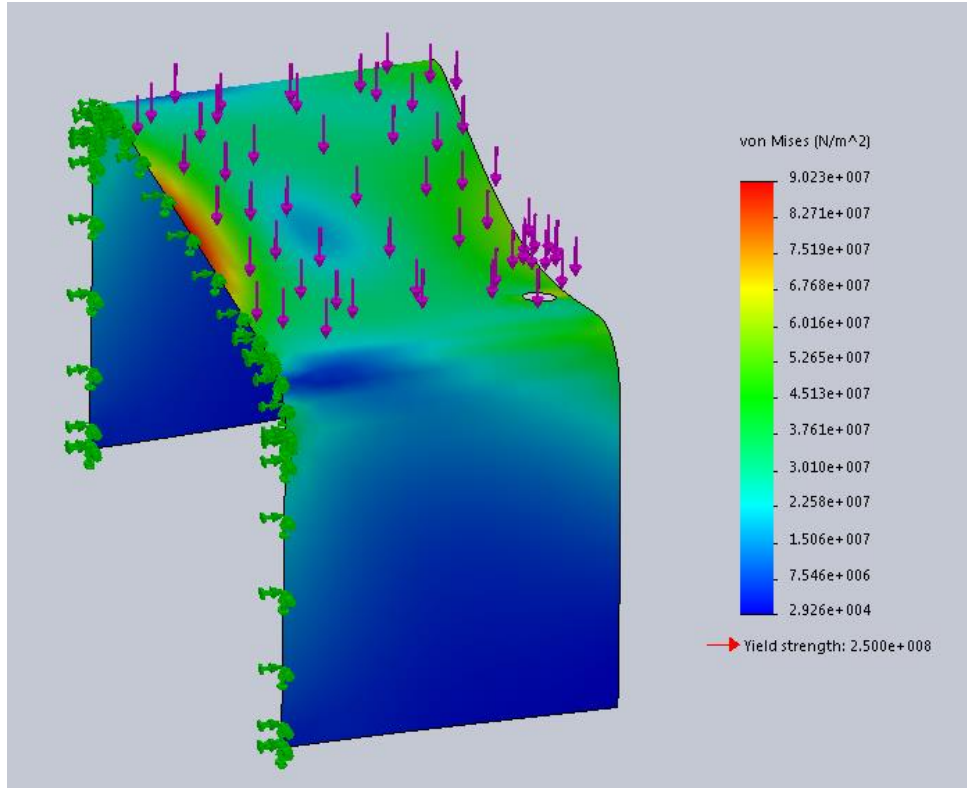

Figure 45: PTO master shield stress simulation with 1200 N load and 11 gauge A36 steel

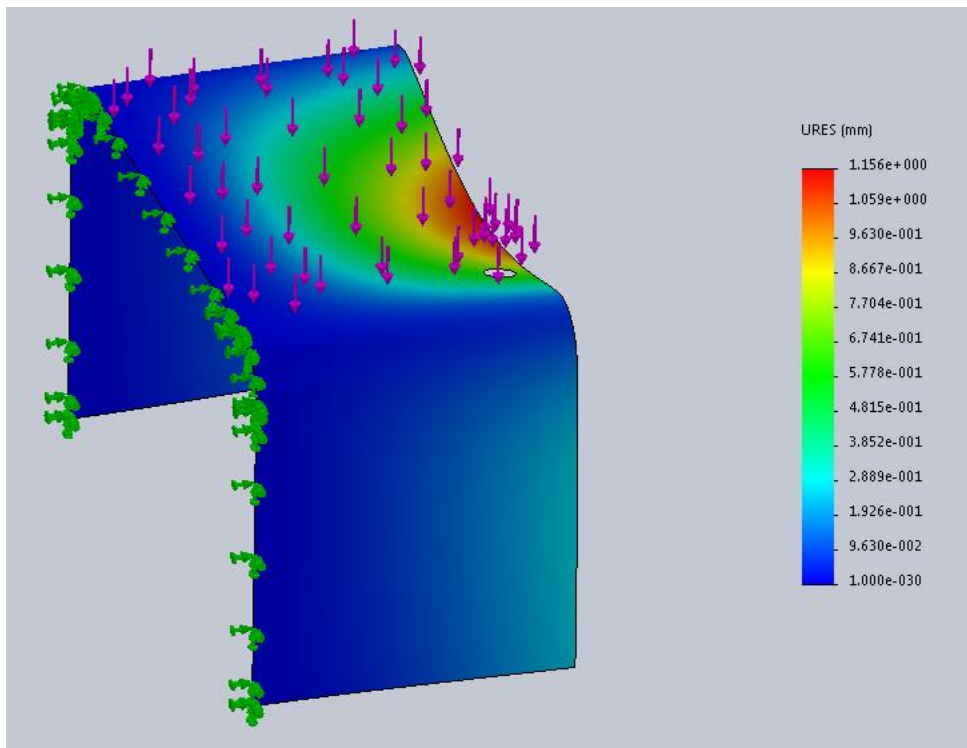

Figure 46: PTO master shield deflection simulation with 1200 N load and 11 gauge A36 steel

OSHA regulation 1928(b)(1)(iii) and (iv) states that “Signs shall be placed at prominent locations on tractors and power take-off driven equipment specifying that power drive system safety shields must be kept in place.” PTO shields are generally able to rotate up away from their downward position to allow for easier connection of an implement to the PTO shaft. Because this is not necessary for prototype and testing purposes the PTO shield will be welded to the face of PTO mount. Additionally proper safety warning signs or stickers, like Figure 49, were be placed on the attachment to give proper warnings for PTO safety, pinch points, high pressure hydraulic oil, and hot surfaces. Guidelines for proper safety images are outlined in ANSI/ASABE Standard AD11384:1995(April 2011).

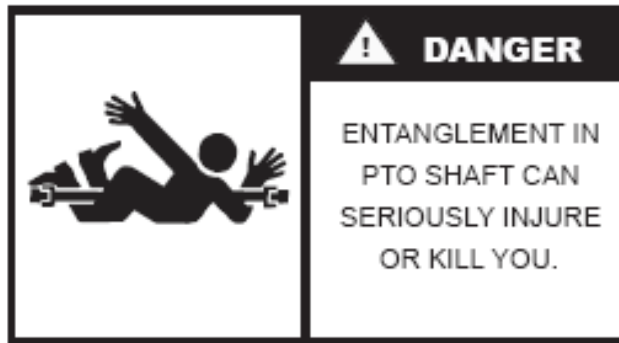

Figure 47: PTO Safety Sign

Flying Debris Safety

The addition of rock shield may need to be an added option to the attachment as it will allow the windrower to pull PTO powered implements that may throw debris towards the cab such as a PTO driven mower. Because the windrower is operating engine forward while using the attachment, what would normally be considered the front windshield is now acting as the rear windshield. This means there is a large surface area of glass that has the potential of having foreign objects thrown through it by the PTO powered implement. While it was not necessary to build a rock shield for prototype purposes, this should be addressed by MacDon if they decide to market this product.

Prototype

With all aspects of the design previously described taken into consideration, the following prototype, seen in Figure 50, was fabricated and built.



Figure 48: Project Prototype: The Mule 2.0

Testing

To verify the performance of the prototype the PTO was attached to a PTO dynamometer, seen in Figure 52. Torque (ft*lb), shaft speed (RPM), and power (HP) were read directly from the dynamometer's display. From these values performance curves were generated. The draper circuit's pressure was adjusted up to 4300 as previously stated by adjusting the settings in Figure 52. The wiring harness was confirmed to provide the proper header code of 0100. Dynamometer tests were conducted by setting the PTO rpm at a desired number at full throttle and with engine and hydraulic at normal operating temperatures as per the testing protocols in the tech manual. Load was gradually applied with the dynamometer. Torque and rpm values were taken until the system was in danger of locking down the hydraulic motor.

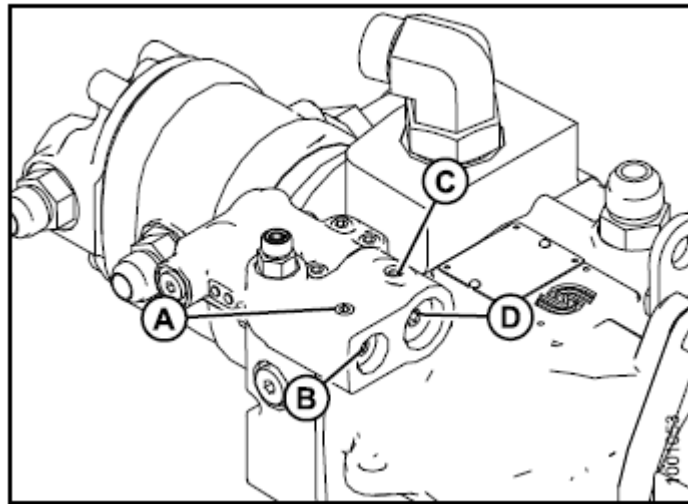

Figure 49: Draper Hydraulic Motor Adjustment Diagram from M155 Tech Manual



Figure 50: PTO Dynamometer Testing Setup

The first test of the system was run with the engine ISC (Intermediate Speed Control) at 1800 RPM. Draper flow was adjust on the GSL controls to reach desired RPM. This test only achieved 30 HP as seen in Figure 53. This was only 31% of the theoretical horsepower the system should have been able to produce with the given header inputs. The knife drive alone should have created an output power almost double that which the test displayed. Further troubleshooting of both lines then occurred in order to determine the root of the perceived flowrate loss.

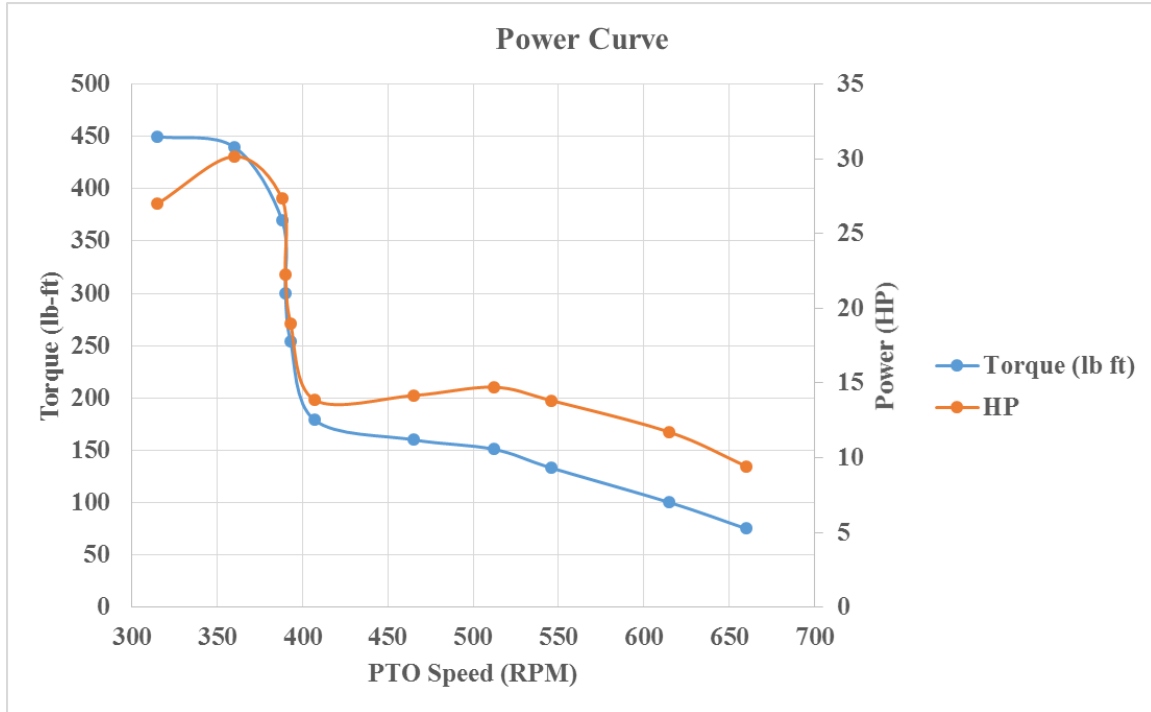

Figure 51: PTO Power Curve from First Test

After the initial dynamometer test it was determined due to the uncertainty of the combination of the Knife and Draper circuits that the Knife circuit would be tested alone to see if it could meet its theoretical power as shown in Table 12. Additionally, a pressure gauge was placed into the Knife drive’s outlet port, Figure 54, to confirm that the system pressure was reaching 4000 psi. The last test was run with the ISC engine RPM set to 2200. By putting the windrower into Diagnostic Mode and going into the Activate Functions menu only the Knife circuit was energized until the scaled RPM was achieved with no load from the dynamometer. The scaled RPM as previously stated was 810rpm to simulate a 3:1 reduction gearbox.

Table 12: Knife Circuit Theoretical Horsepower Calculation

| Drive Hydraulic Power | | | |
|------------------------------|-----------------------|-----------------------|-----------|
| Pump | Flowrate (gpm) | Pressure (psi) | HP |
| Knife | 29 | 4000 | 68 |



Figure 52: Pressure Gauge Plumbed into Knife Circuit

Figure 55 shows the verification of the knife circuit. The theoretical power was 68 hp with an achieved of 61hp. The results verified that further troubleshooting should be performed in the windrower itself to determine why the system is not performing as expected. Further testing would need to be done in order to find potential issues with solenoids, errors in the CDM, or problems with the windrower's hydraulic components.

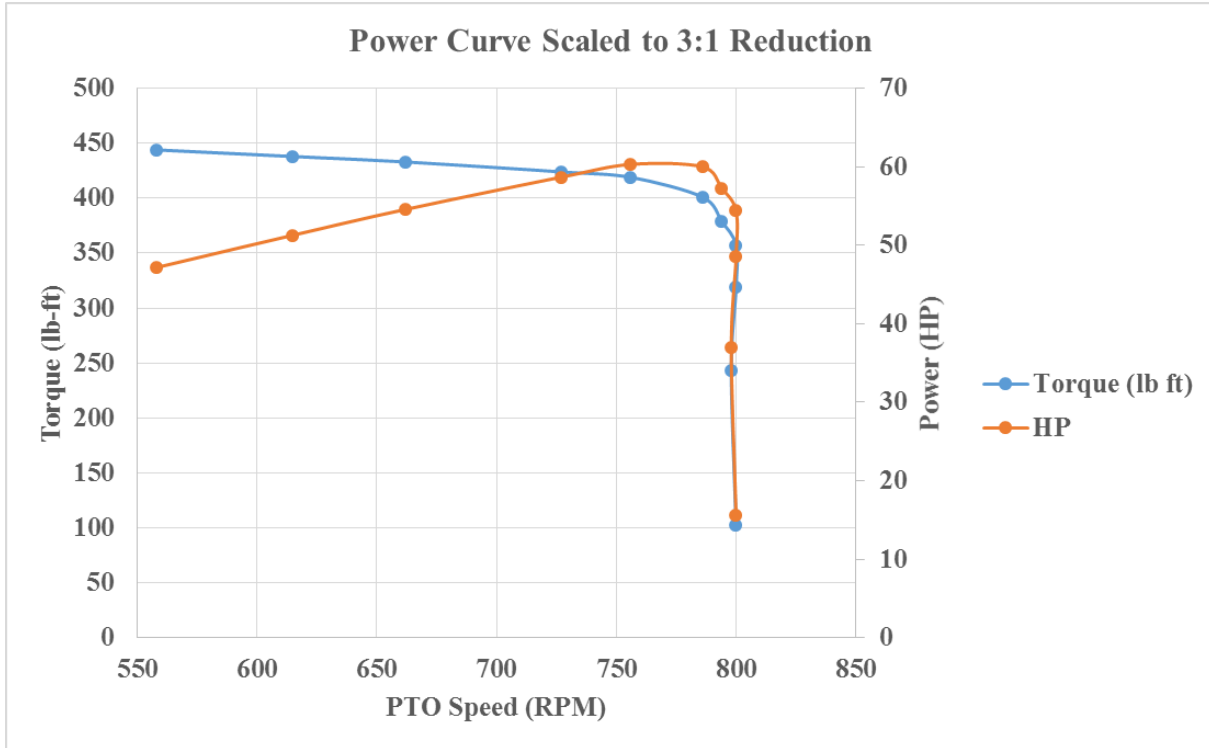

Figure 53: PTO Dynamometer Test with only Knife Circuit Operated Manually

The auxiliary hydraulic outlets are pictured in Figure 56 with dust covers. The top two outlets are controlled by the DWA’s movement circuit. The middle outlets are controlled by the reel fore and aft movement circuit. The bottom single acting outlet is controlled by the reel lift lower circuit. These circuits are all controlled by controls on the operator’s display as previously stated. The two double acting circuit were tested by connecting a hydraulic cylinder to them and moving it both in and out. The outlets were often hard to release though as there was no way to relieve pressure on both sides of the circuit. This will need to be addressed by MacDon.



Figure 54: Hydraulic Auxiliary Outlets

The speed sensor was installed per the owner's manual instructions. The sensor was placed 2 mm away from the surface of the plate it was reading off of. The power wire was confirmed to have 9 volts and the signal wire during operation showed 4.5 volts. However, the sensor did not provide a readout on CDM. No further testing of this system was performed as it is assumed there is an issue with the windrower's wiring harness upstream of the connection.

Recommendations

Based on the design concepts discussed previously and after comparing the advantages and disadvantages of each option, Missing Link Engineering is proposing to MacDon the following combination of concepts for the further design and construction of a functioning prototype for testing purposes as displayed in Figure 57.

The model is designed around as many preexisting MacDon parts as could be reasonably used i.e. gearbox, hydraulic motor, and hydraulic receivers. It met all standards that could be found to apply to it, and if MacDon believes this is paramount then this configuration of the attachment is primed for testing purposes. The square frame provides strength along with ideal mounting locations for hydraulics, PTO, and drawbar. An operator used to operating the windrower with a normal header would have no problem mounting the attachment to the windrower. The openness of the design allows for easy maintenance for an operator and assembly for the manufacturer.

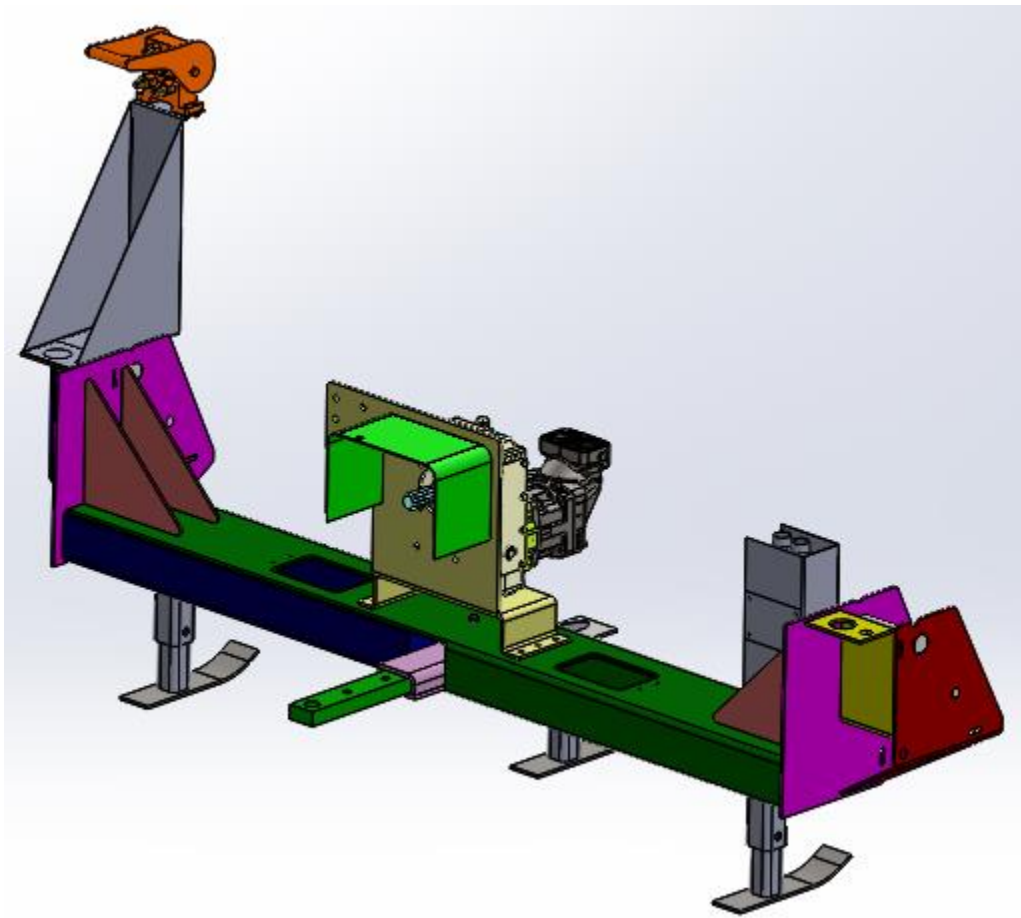

Figure 55: Recommended prototype

Future iterations of this attachment should include the following to increase user friendliness, manufacturability, and to increase cost savings:

- Hydraulic lines should be replaced with bent metal lines to improve routing and cost.
- A safety/Mule engagement switch that on the operators station that:
 - Locks out
 - Lift functions – to keep the lift arms from changing the height of the attachment during operation.
 - Tilt cylinder – to prevent the tilt cylinder from being used
 - Header reverser engagement – to prevent PTO direction changes as the suction hoses cannot handle the pressures of the pressure circuits
 - Allows:
 - Header engagement in engine forward – as the attachment will be operated in the engine forward configuration and currently the header cannot be engaged in this configuration.
- A gearbox with a 3:1 reduction going from the hydraulic motor to the PTO output should be used to attain proper speed and power.
- Automatic pressure adjustments via solenoid or electric motor to the draper pump would make the attachment more appealing to producers as it is currently labor intensive to adjust them.
- PTO motor connection points and wiring harness connector should be routed to a single plate to simplify connections.
- The middle skid may need to be moved or a fourth one may need to be added. The middle currently has very little clearance and may interfere with a windrow if the attachment is used with a baler.

Prototype Budget

Table 13: Prototype budget breakdown

| Component | Source | Qty | Cost |
|--|--------------------------|--------------|-------------------|
| Frame and Drawbar | | | |
| 1/16" Plate | Stillwater Steel | 2'x4' | \$21.60 |
| 1/4" Plate | Stillwater Steel | 4'x16' | \$399.36 |
| 3/8" Plate | Stillwater Steel | 1'x1' | \$26.08 |
| Square Tubing | Stillwater Steel | 3' | \$30.88 |
| Drawbar | John Deere | 1 | \$304.50 |
| 2" Drawbar pin (1' stock) A36 | Stillwater Steel | 1 | \$20.00 |
| PTO Shield (11 gauge 1'x4' sheet) | onlinemetals.com | 1 | \$25.00 |
| PTO | | | |
| Gearbox | MacDon (Comer) | 1 | \$684.00 |
| Hydraulic Motor | MacDon (Parker-Hannifin) | 1 | \$1,437.00 |
| Hydraulic Manifold | onlinemetals.com | 1 | \$80.00 |
| Hoses and Fittings | NAPA | 5 | \$600.00 |
| Check Valves | Stucchi | 2 | \$60.00 |
| Flat Face Connectors | MacDon | 4 | \$200.00 |
| Speed Sensor | MacDon | 1 | \$70.00 |
| Wiring Harnesses | MacDon | 1 | \$60.00 |
| Auxiliary Hydraulics | | | |
| Hydraulic Receiver Block | MacDon | 1 | \$980.00 |
| Pioneer outlets | McMaster-Carr | 5 | \$100.00 |
| Dust Covers | McMaster-Carr | 5 | \$20.00 |
| Flat Face Connectors | Livingston Machinery | 4 | \$200.00 |
| Hoses and Fittings | NAPA | 5 | \$220.00 |
| Shop/Manufacturing | | | |
| Cutting/Welding/Assembly/Etc (\$20/hr) | Biosystems Shop | 20 hrs | \$400.00 |
| Misc. Hardware | | | |
| Nuts/Bolts/Pins | Biosystems Shop | 23 | \$20.00 |
| | | Total | \$5,933.42 |

Project Schedule

Table 14: Project Work Breakdown Structure

| Work Breakdown Structure (Fall) | | | |
|--|----------|--------------|--------------|
| Task Name | Duration | Start | Finish |
| Define Client Requirements | 5 days | Mon 9/28/15 | Fri 10/2/15 |
| Research Applicable Patents | 11 days | Mon 10/5/15 | Mon 10/19/15 |
| Establish Multiple Design Ideas | 20 days | Mon 10/5/15 | Fri 10/30/15 |
| Technical Requirements | 6 days | Mon 10/5/15 | Mon 10/12/15 |
| Power and Strain Analysis | 15 days | Tue 10/13/15 | Mon 11/2/15 |
| Schedule of Work | 5 days | Tue 11/3/15 | Mon 11/9/15 |
| Design Presentation | 1 day | Tue 11/10/15 | Tue 11/10/15 |
| First Draft Final Report | 1 day | Tue 11/10/15 | Tue 11/10/15 |
| Compose Final Report | 16 days | Wed 11/11/15 | Wed 12/2/15 |
| Deliver Fall Report to Client | 1 day | Thu 12/3/15 | Thu 12/3/15 |
| Finalize Design | 2 days | Fri 12/4/15 | Mon 12/7/15 |
| Work Breakdown Structure (Spring) | | | |
| Task Name | Duration | Start | Finish |
| Order Hydraulic Pumps | 6 days | Tue 12/8/15 | Tue 12/15/15 |
| Order hydraulic block and couplers | 6 days | Tue 12/8/15 | Tue 12/15/15 |
| Test Existing lines to find pressure and flow loss | 6 days | Wed 12/16/15 | Wed 12/23/15 |
| Fabricate PTO Assembly | 10 days | Thu 12/24/15 | Wed 1/6/16 |
| Build First Prototype | 61 days | Thu 1/7/16 | Thu 3/31/16 |
| First Draft Final Report | 1 day | Wed 3/30/16 | Wed 3/30/16 |
| Initial Design Performance | 2 days | Thu 3/31/16 | Fri 4/1/16 |
| Revise Prototype Design | 11 days | Fri 4/1/16 | Fri 4/15/16 |
| Second Draft Final Report | 1 day | Fri 4/15/16 | Fri 4/15/16 |
| Final Prototype | 2 days | Fri 4/15/16 | Mon 4/18/16 |
| Test Performance | 8 days | Mon 4/18/16 | Wed 4/27/16 |
| Spring Presentation | 1 day | Thu 4/28/16 | Thu 4/28/16 |
| Write Final Report | 6 days | Fri 4/29/16 | Fri 5/6/16 |

References

Dunn, J.T., et al. 2007. Tractor with reversible operator position for operation and transport, U.S. Patent No. 7159687B2

Fadden, D. K., and Fosco, L.D. 1970. Tractor quick hitch attachment, U.S. Patent No. 3531140A

Honey, G. J. 1991. Swather attachment for bi-directional tractor, U.S. Patent No. 5031394A

Degelman, W. J. 2000. Multi-functional self-propelled farm tractor, U.S. Patent No. 6160643B1

Paumier, J. 2002, Vertical underground stump grinding apparatus, U.S. Patent No. 20040098885A1

ANSI/ASABE Standard AD6489-3:2004, July 2004, “Agricultural vehicles-Mechanical connections between towed and towing vehicles-Part 3: Tractor drawbar,”www.asabe.org

ANSI/ASABE Standard AD11384:1995 (April 2011), May 2011, “Tractors, machinery for agricultural and forestry, powered lawn and garden equipment – Safety signs and hazard pictorials – General principles,” www.asabe.org

ASABE/ISO 500-1:2014, Feb 2015, “Agricultural tractors — Rear-mounted power take-off types 1, 2, 3 and 4 - Part 1: General specifications, safety requirements, dimensions for master shield and clearance zone,” www.asabe.org

ASABE/ISO 500-3:2014, Feb 2015, “Agricultural tractors – Rear-mounted power take-off types 1, 2, 3, and 4 - Part 3: Main PTO dimensions and spline dimensions, location of PTO,” www.asabe.org

ANSI/ASAE S366.2, May 2004, “Agricultural tractors and machinery – General purpose quick-action hydraulic couples,” ISO 5675:1992, www.asabe.org

Occupational Safety & Health Administration [OSHA]. 1976. Regulations (Standard – 29 CFR).1928. Retrieved from http://www.osha.gov/pls/oshaweb/owadisp.show_document?p_table=STANDARDS&p_id=10958

"Farm Injury Resource Center." *Farm Injury Resource Center*. N.p., n.d. Web. 29 Nov. 2015.

MacDon. (2012). *M155 Self-Propelled Windrower: Operator's Manual*. Winnepeg, CA

MacDon. (2012). *D65 Harvest Header For Self-Propelled Windrowers: Operator's Manual*. Winnepeg, CA

Budynas, R. G., Nisbett, J. K., (2015). *Shigley's Mechanical Engineering Design* (10th ed.). New York, NY: McGraw-Hill Education

Srivistava, A. K., et al., (2012). *Engineering Principles of Agricultural Machines* (2nd ed.). ASABE

www.engineeringtoolbox.com

www.tractorhouse.com

Appendix

Fall Semester Frame Design Stress Life Calculation

| ALL UNITS IN METRIC | | <i>Square tubing mounting style, with squared mounts</i> | | | | | | | | | | | | |
|---------------------------------------|-------------|--|----------|----------|--|-------|-------|-------|-------|-------|---|------------|-----|-----|
| tractor model | IH 1086 | S_e | $S_{e'}$ | S_{ut} | k_a | k_b | k_c | k_d | k_e | k_f | material is A500 Grade C | | | |
| tractor power | 84.3 | 140.93 | 213.7375 | 427.475 | 0.81 | 1 | 1 | 1 | 0.814 | 1 | S_{ut} | S_y | | |
| baler model | Vermeer 605 | assumed initial size .1524x.1524 m approx inch dimensions 6"x6" | | | $S_e = S_{e'} k_a k_b k_c k_d k_e k_f$ | | | | | | σ_a | σ_m | Mpa | Mpa |
| baler weight w/ bale | 40270.04 | | | | | | | | | | 57.95 | 28.97 | | |
| | N | | | | | | | | | | Mpa | Mpa | | |
| coefficient of static friction | 0.35 | | | | | | | | | | ASME- elliptic | | | |
| drawbar force(vertical) | 0 | | | | | | | | | | n_f 2.43 FOR BENDING | | | |
| | N | | | | | | | | | | n_f ∞ FOR SHEAR | | | |
| wheel force(vertical) | 40270.04 | | | | | | | | | | $\left(\frac{\sigma_a}{S_e}\right)^2 + \left(\frac{\sigma_m}{S_y}\right)^2 = \frac{1}{n_f^2}$ | | | |
| force to get baler moving(horizontal) | 14094.514 | | | | | | | | | | | | | |
| | N | | | | | | | | | | | | | |
| speed of baling(approx) | 11.26 | | | | | | | | | | | | | |
| | km/hr | | | | | | | | | | | | | |

Figure 56: Pure Bending Factor of Safety Calculations

| ALL UNITS IN METRIC | | <i>Square tubing mounting style with triangular mounts</i> | | | | | | | | | | | |
|---------------------------------------|-------------|--|------------|----------------|--|--|--|--|--|--|-----------|---|------|
| tractor model | IH 1086 | | | | | | | | | | | | |
| tractor power | 84.3 | | | | | | | | | | | | |
| baler model | Vermeer 605 | | | | | | | | | | | | |
| baler weight w/ bale | 40270.04 | σ_a | σ_m | ASME- elliptic | | | | | | | | | |
| | N | 15.60 | 7.80 | | | | | | | | | n_f | 9.04 |
| coefficient of static friction | 0.35 | Mpa | Mpa | | | | | | | | | FOR BENDING | |
| drawbar force(vertical) | 0 | | | | | | | | | | n_f | | |
| | N | | | | | | | | | | FOR SHEAR | | |
| wheel force(vertical) | 40270.04 | | | | | | | | | | | $\left(\frac{\sigma_a}{S_e}\right)^2 + \left(\frac{\sigma_m}{S_y}\right)^2 = \frac{1}{n_f^2}$ | |
| force to get baler moving(horizontal) | 14094.514 | | | | | | | | | | | | |
| | N | | | | | | | | | | | | |
| speed of baling(approx) | 11.26 | | | | | | | | | | | | |
| | km/hr | | | | | | | | | | | | |

Figure 57: Split Bending and Shear Factor of Safety Calculations

| | | <i>Flat plate mounting style with triangular positioning</i> | | | | | | | | | | | | |
|---------------------------------------|-------------|--|-------|----------|-------|----------|-------|-------|-------|-------|--|------------|------------|--|
| tractor model | IH 1086 | | | | | | | | | | | | | |
| tractor power | 84.3 kw | S_e | S_e | S_{ut} | k_s | k_b | k_c | k_d | k_e | k_f | | σ_a | σ_m | |
| | | 90.51 | 190 | 380 | 0.81 | 0.85 | 0.85 | 1 | 0.814 | 1 | | 30.97 | 15.48 | |
| | | | | | | | | | | | | Mpa | Mpa | |
| baler model | Vermeer 605 | | | | | | | | | | | | | |
| baler weight w/ bale | 40270.04 N | | | | | | | | | | | | | |
| | | | | | n_f | 9.035524 | | | | | | S_{ut} | S_y | |
| | | | | | | | | | | | | 380 | 210 | |
| | | | | | | | | | | | | Mpa | Mpa | |
| coefficient of static friction | 0.35 | | | | | | | | | | | | | |
| | 0 | | | | | | | | | | | | | |
| drawbar force(vertical) | N | | | | | | | | | | | | | |
| | 40270.04 | | | | | | | | | | | | | |
| wheel force(vertical) | N | | | | | | | | | | | | | |
| force to get baler moving(horizontal) | 14094.514 N | | | | | | | | | | | | | |
| | | | | | | | | | | | | | | |
| speed of baling(approx) | 11.26 km/hr | | | | | | | | | | | | | |
| | | | | | | | | | | | | | | |

Figure 58: Split Bending and Shear Stress Factor of Safety Calculations with Flat Plate

Hydraulic Manifold Drawings (units in inches)

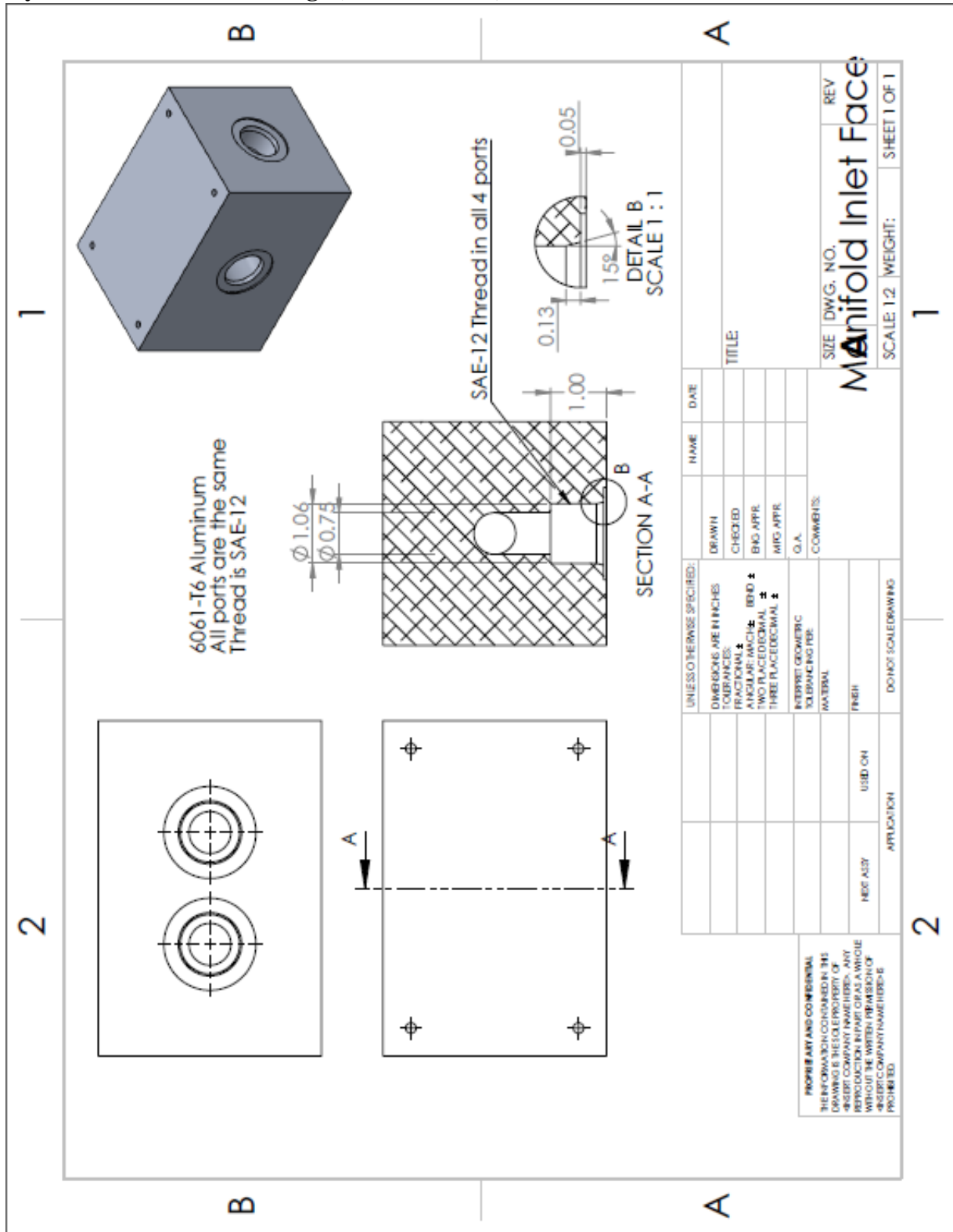

| | | | |
|--------------------------------------|--|----------------------|------|
| UNLESS OTHERWISE SPECIFIED: | | NAME | DATE |
| DIMENSIONS ARE IN INCHES | | DRAWN | |
| TOLERANCES: | | CHECKED | |
| FRACTIONAL ± | | ENG. APPR. | |
| ANGULAR: MAX ± BEND ± | | MFG. APPR. | |
| TWO PLACED DECIMAL ± | | G.A. | |
| THREE PLACED DECIMAL ± | | COMMENTS: | |
| INTERPRET GEOMETRIC TOLERANCING PER: | | | |
| MATERIAL: | | | |
| FINISH: | | | |
| NEXT ASY | | USED ON | |
| APPLICATION | | DO NOT SCALE DRAWING | |

PROPERTY AND CONFIDENTIAL INFORMATION CONTAINED IN THIS DRAWING IS THE SOLE PROPERTY OF MISSING LINK ENGINEERING. ANY REUSE OR REPRODUCTION OF THIS DRAWING WITHOUT THE WRITTEN PERMISSION OF MISSING LINK ENGINEERING IS PROHIBITED.

SIZE DWG. NO. REV
Manifold Inlet Face
SCALE: 1:2 WEIGHT: SHEET 1 OF 1

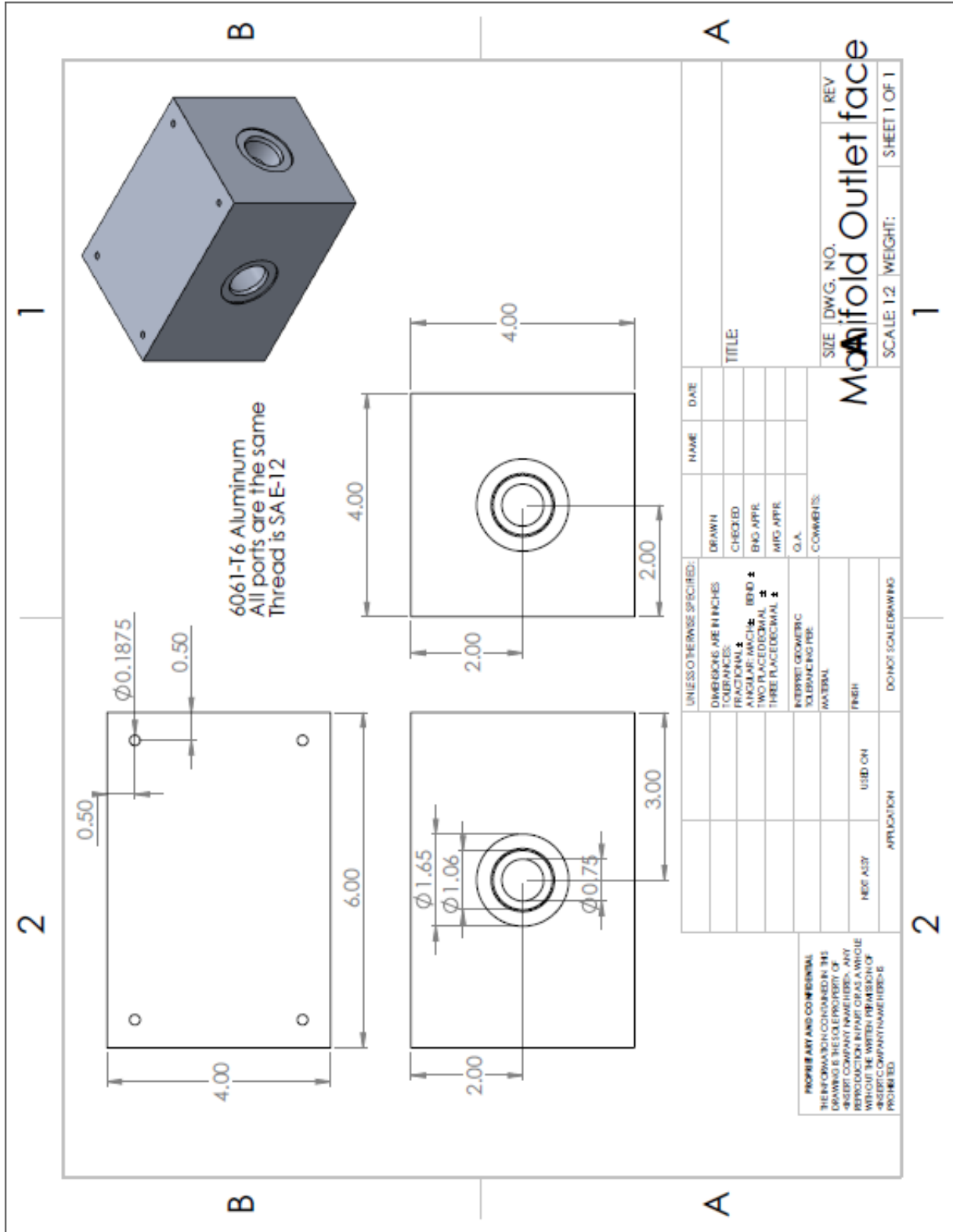

Structural Member Drawings (units in mm)

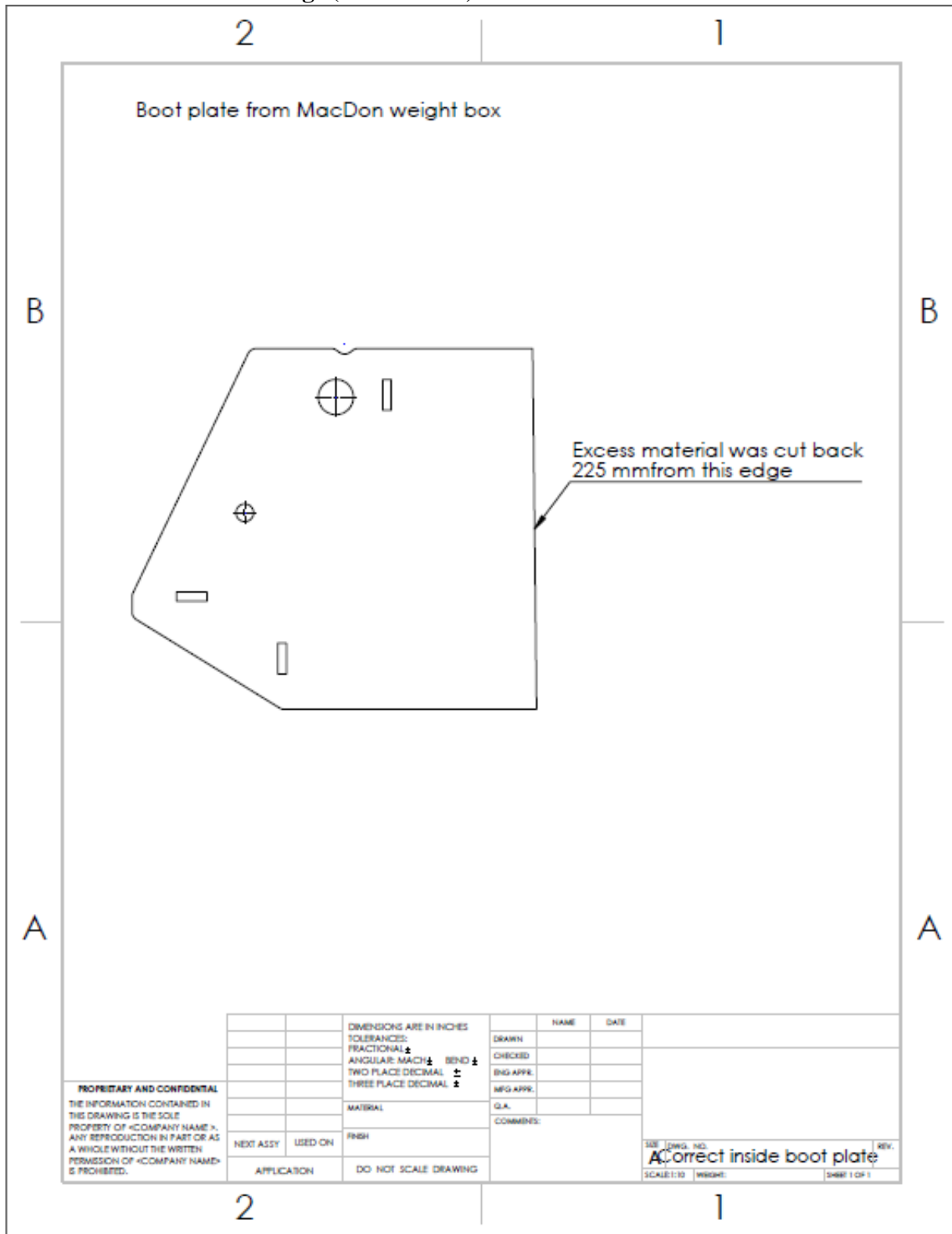

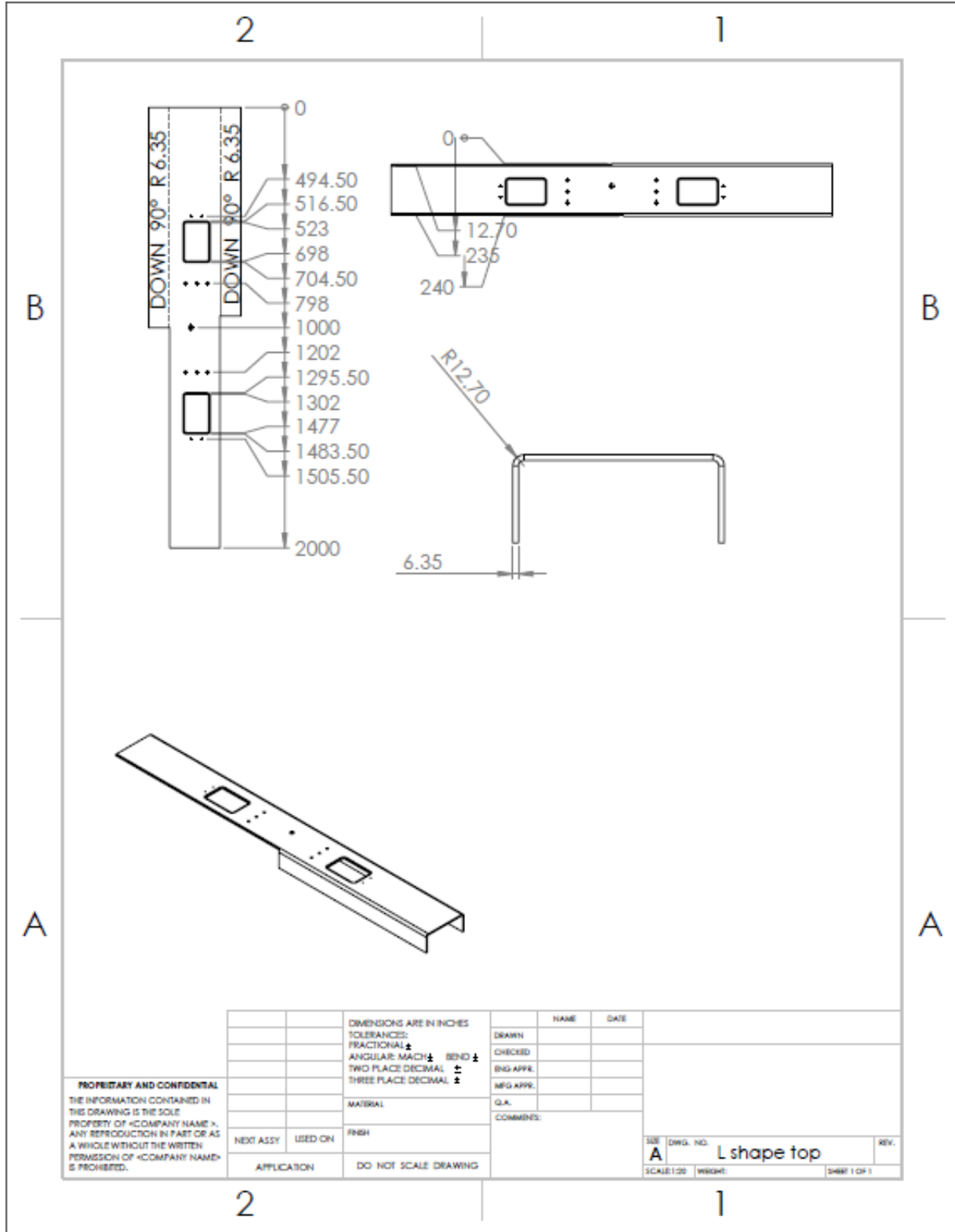

PROPRIETARY AND CONFIDENTIAL
 THE INFORMATION CONTAINED IN THIS DRAWING IS THE SOLE PROPERTY OF <COMPANY NAME>. ANY REPRODUCTION IN PART OR AS A WHOLE WITHOUT THE WRITTEN PERMISSION OF <COMPANY NAME> IS PROHIBITED.

| | | | | | |
|-------------|----------------------|--------------------------|---|-------------|----------------------|
| | | DIMENSIONS ARE IN INCHES | | NAME | DATE |
| | | TOLERANCES: | | DRAWN | |
| | | FRACTIONAL ± | | CHECKED | |
| | | ANGULAR: MATCH ± BEND ± | | ENG APPR. | |
| | | TWO PLACE DECIMAL ± | | MFG APPR. | |
| | | THREE PLACE DECIMAL ± | | Q.A. | |
| | | MATERIAL | | COMMENTS: | |
| NEXT ASSY | USED ON | FINISH | | SIZE | DWG. NO. |
| APPLICATION | DO NOT SCALE DRAWING | | A | | L shape top |
| | | | | SCALE: 1:20 | WEIGHT: SHEET 1 OF 1 |

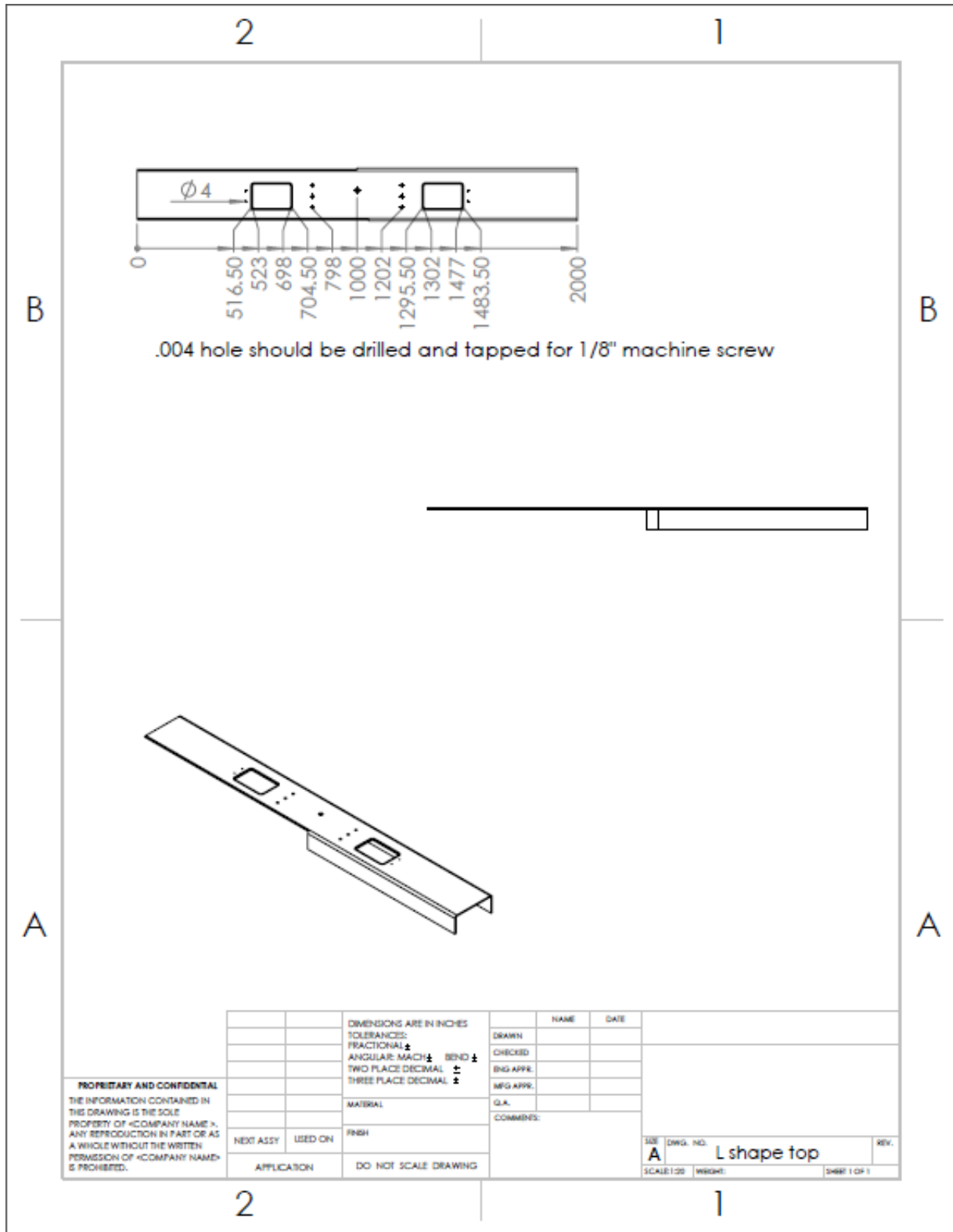

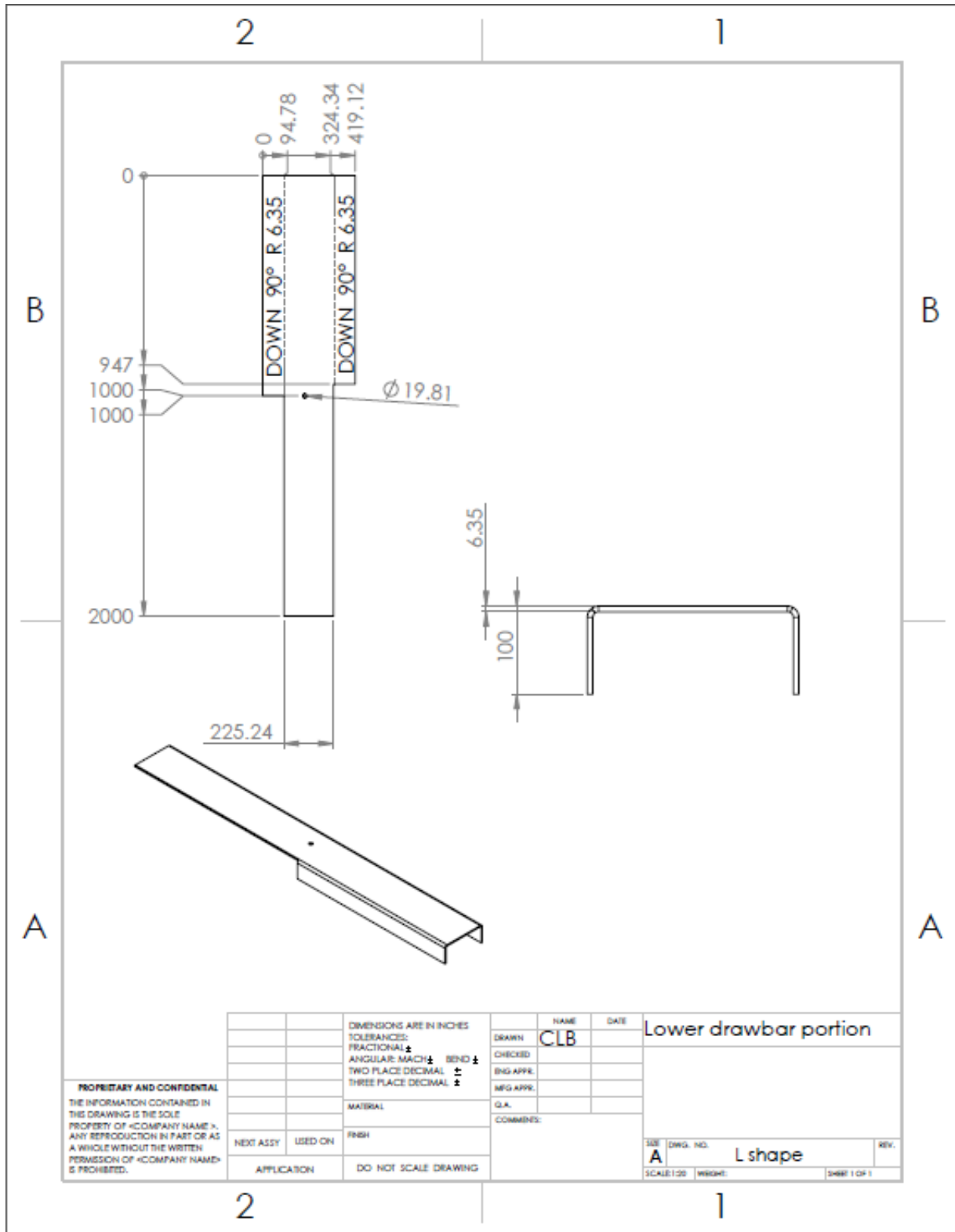

PROPRIETARY AND CONFIDENTIAL
 THE INFORMATION CONTAINED IN THIS DRAWING IS THE SOLE PROPERTY OF <COMPANY NAME>. ANY REPRODUCTION IN PART OR AS A WHOLE WITHOUT THE WRITTEN PERMISSION OF <COMPANY NAME> IS PROHIBITED.

| | | | | | | |
|-------------|---------|--------------------------|--|-----------|------|--|
| | | DIMENSIONS ARE IN INCHES | | NAME | DATE | Lower drawbar portion |
| | | TOLERANCES: | | CLB | | |
| | | FRACTIONAL ± | | CHECKED | | |
| | | ANGULAR: MATCH ± BEND ± | | ENG APPR. | | |
| | | TWO PLACE DECIMAL ± | | MFG APPR. | | |
| | | THREE PLACE DECIMAL ± | | Q.A. | | |
| | | MATERIAL | | COMMENTS: | | SIZE A DWG. NO. L shape REV. SCALE: 1:20 WEIGHT: SHEET 1 OF 1 |
| NEXT ASSY | USED ON | FINISH | | | | |
| APPLICATION | | DO NOT SCALE DRAWING | | | | |

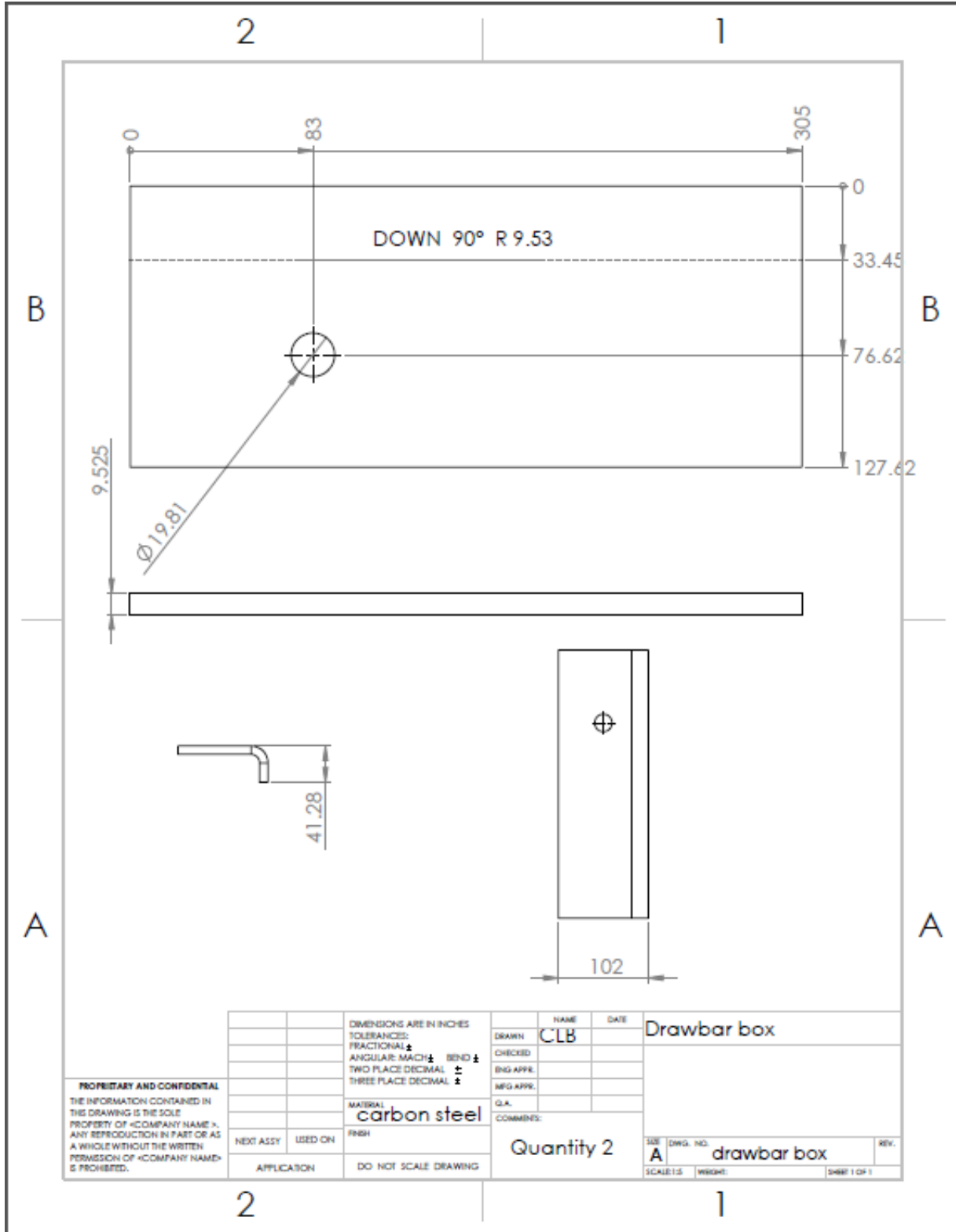

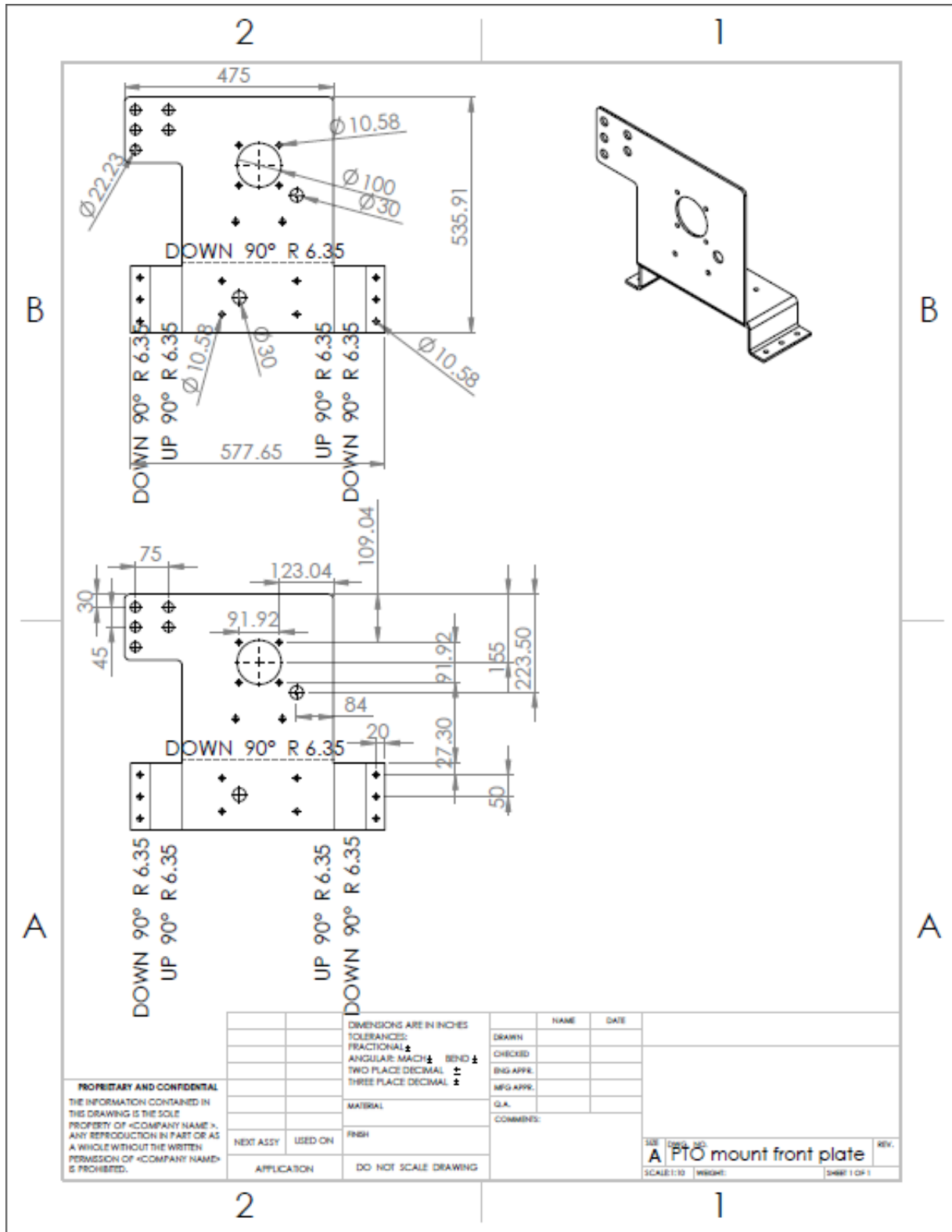

PROPRIETARY AND CONFIDENTIAL
 THE INFORMATION CONTAINED IN THIS DRAWING IS THE SOLE PROPERTY OF «COMPANY NAME». ANY REPRODUCTION IN PART OR AS A WHOLE WITHOUT THE WRITTEN PERMISSION OF «COMPANY NAME» IS PROHIBITED.

| | | | |
|--------------------------|----------------------|-------------------------|----------------------|
| DIMENSIONS ARE IN INCHES | | NAME | DATE |
| TOLERANCES: | | DRAWN | |
| FRACTIONAL ± | | CHECKED | |
| ANGULAR: MATCH ± BEND ± | | ENG APPR. | |
| TWO PLACE DECIMAL ± | | MFG APPR. | |
| THREE PLACE DECIMAL ± | | Q.A. | |
| MATERIAL | | COMMENTS: | |
| NEXT ASSY | USED ON | REV. | |
| FINISH | | A PTO mount front plate | |
| APPLICATION | DO NOT SCALE DRAWING | SCALE: 1:10 | WEIGHT: SHEET 1 OF 1 |

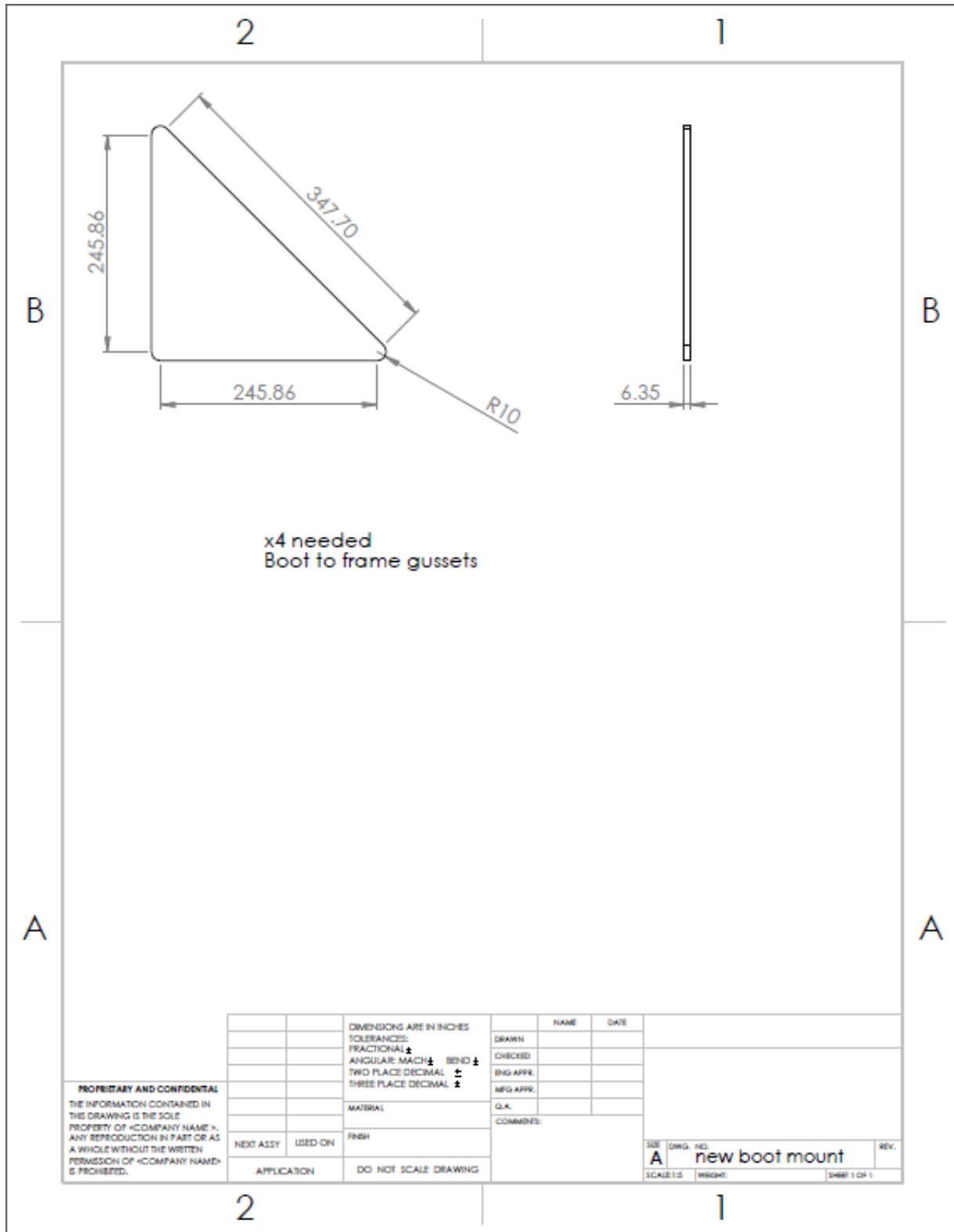

PROPRIETARY AND CONFIDENTIAL
 THE INFORMATION CONTAINED IN
 THIS DRAWING IS THE SOLE
 PROPERTY OF <COMPANY NAME>.
 ANY REPRODUCTION IN PART OR AS
 A WHOLE WITHOUT THE WRITTEN
 PERMISSION OF <COMPANY NAME>
 IS PROHIBITED.

| | | | | | |
|-------------|---------|--------------------------|--|--------------|----------------|
| | | DIMENSIONS ARE IN INCHES | | NAME | DATE |
| | | TOLERANCES: | | DRAWN | |
| | | FRACTIONAL: ± | | CHECKED | |
| | | ANGULAR: MATCH ± BEND ± | | ENG APPR. | |
| | | TWO PLACE DECIMAL: ± | | MFG APPR. | |
| | | THREE PLACE DECIMAL: ± | | Q.A. | |
| | | MATERIAL | | COMMENTS: | |
| NEXT ASSY | USED ON | FINISH | | | |
| APPLICATION | | DO NOT SCALE DRAWING | | SIZE | DWG. NO. |
| | | | | A | new boot mount |
| | | | | SCALE: 1:1 | WEEKS: |
| | | | | SHEET 1 OF 1 | |

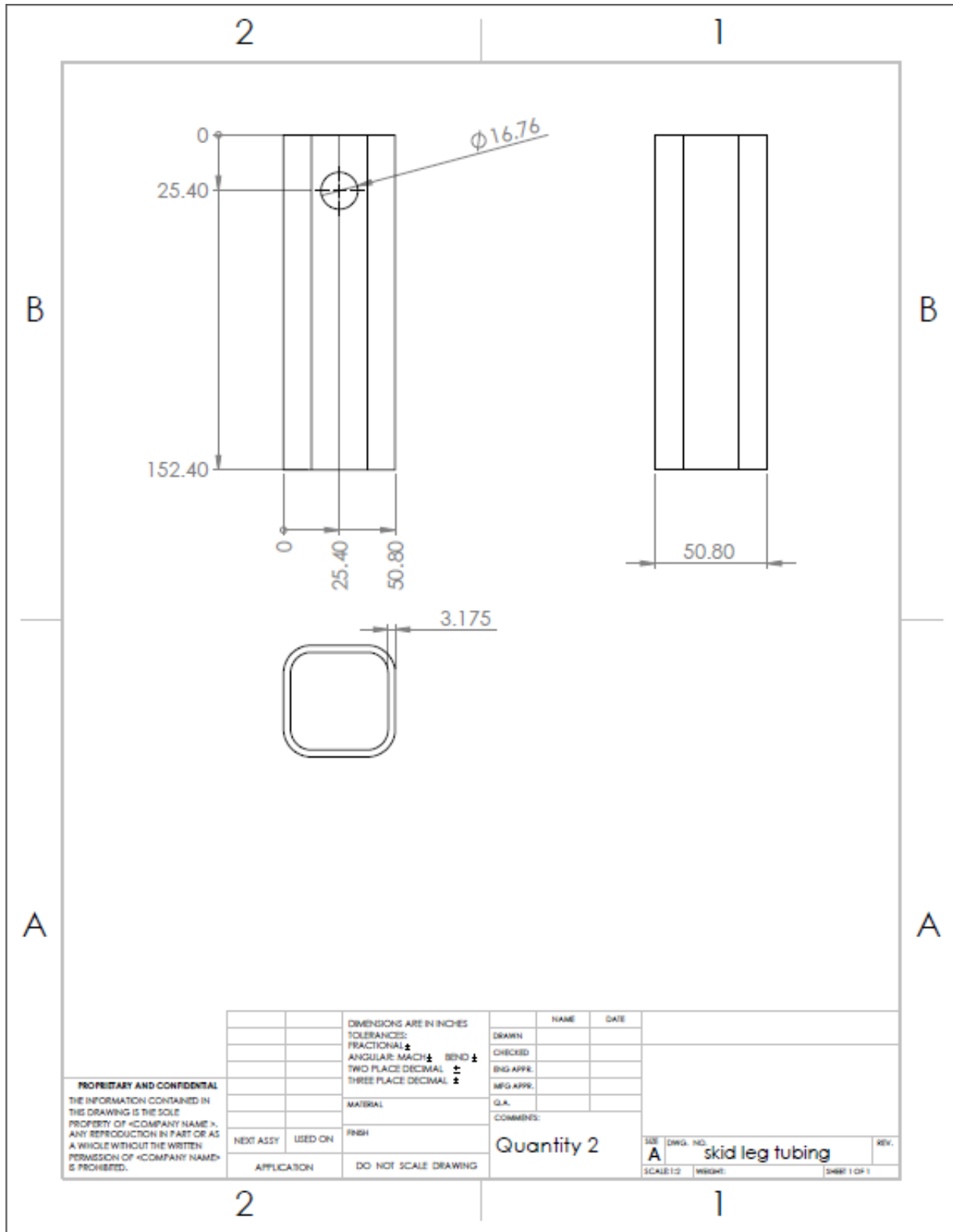

| | | | | | |
|--|---------|--------------------------|-----------|------------|--------------------------|
| <p>PROPRIETARY AND CONFIDENTIAL THE INFORMATION CONTAINED IN THIS DRAWING IS THE SOLE PROPERTY OF <COMPANY NAME>. ANY REPRODUCTION IN PART OR AS A WHOLE WITHOUT THE WRITTEN PERMISSION OF <COMPANY NAME> IS PROHIBITED.</p> | | DIMENSIONS ARE IN INCHES | | NAME | DATE |
| | | TOLERANCES: | | DRAWN | |
| | | FRACTIONAL ± | | CHECKED | |
| | | ANGULAR: MATCH ± BEND ± | | ENG APPR. | |
| TWO PLACE DECIMAL ± | | MFG APPR. | | | |
| THREE PLACE DECIMAL ± | | Q.A. | | | |
| MATERIAL | | COMMENTS: | | Quantity 2 | |
| NEXT ASSY | USED ON | FINISH | SIZE A | | DWG. NO. skid leg tubing |
| APPLICATION | | DO NOT SCALE DRAWING | SCALE 1:2 | WEIGHT: | SHEET 1 OF 1 |

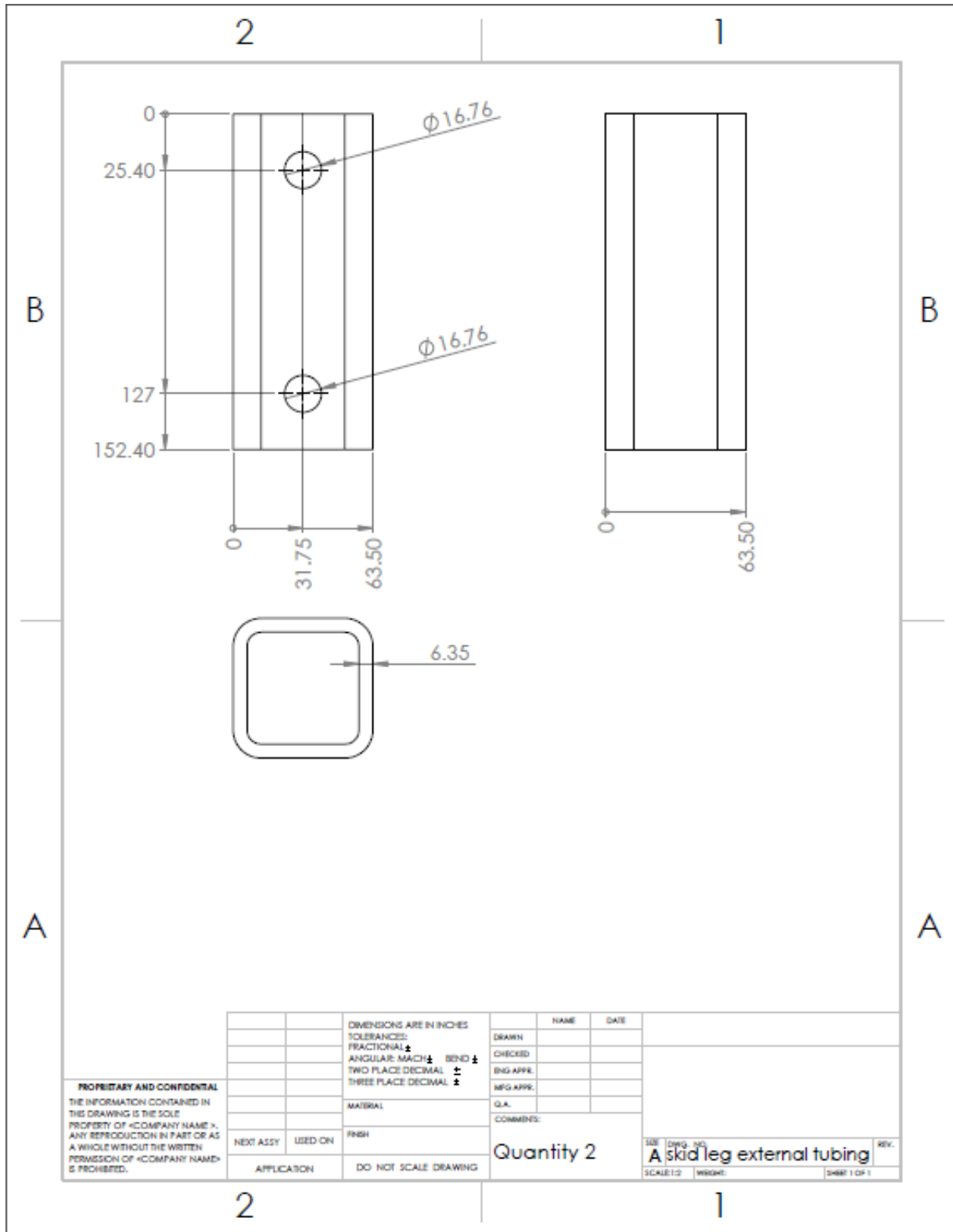

PROPRIETARY AND CONFIDENTIAL
 THE INFORMATION CONTAINED IN THIS DRAWING IS THE SOLE PROPERTY OF <COMPANY NAME>. ANY REPRODUCTION IN PART OR AS A WHOLE WITHOUT THE WRITTEN PERMISSION OF <COMPANY NAME> IS PROHIBITED.

| | | | | | |
|-------------|---------|---------------------------------|--|---|------|
| | | DIMENSIONS ARE IN INCHES | | NAME | DATE |
| | | TOLERANCES: | | DRAWN | |
| | | FRACTIONAL \pm | | CHECKED | |
| | | ANGULAR: MATCH \pm BEND \pm | | ENG APPR. | |
| | | TWO PLACE DECIMAL \pm | | MFG APPR. | |
| | | THREE PLACE DECIMAL \pm | | Q.A. | |
| | | MATERIAL | | COMMENTS: | |
| NEXT ASSY | USED ON | FINISH | | Quantity 2 | |
| APPLICATION | | DO NOT SCALE DRAWING | | SIZE: (DRG. NO.) A skid leg external tubing SCALE: 1:2 WEIGHT: SHEET 1 OF 1 | |

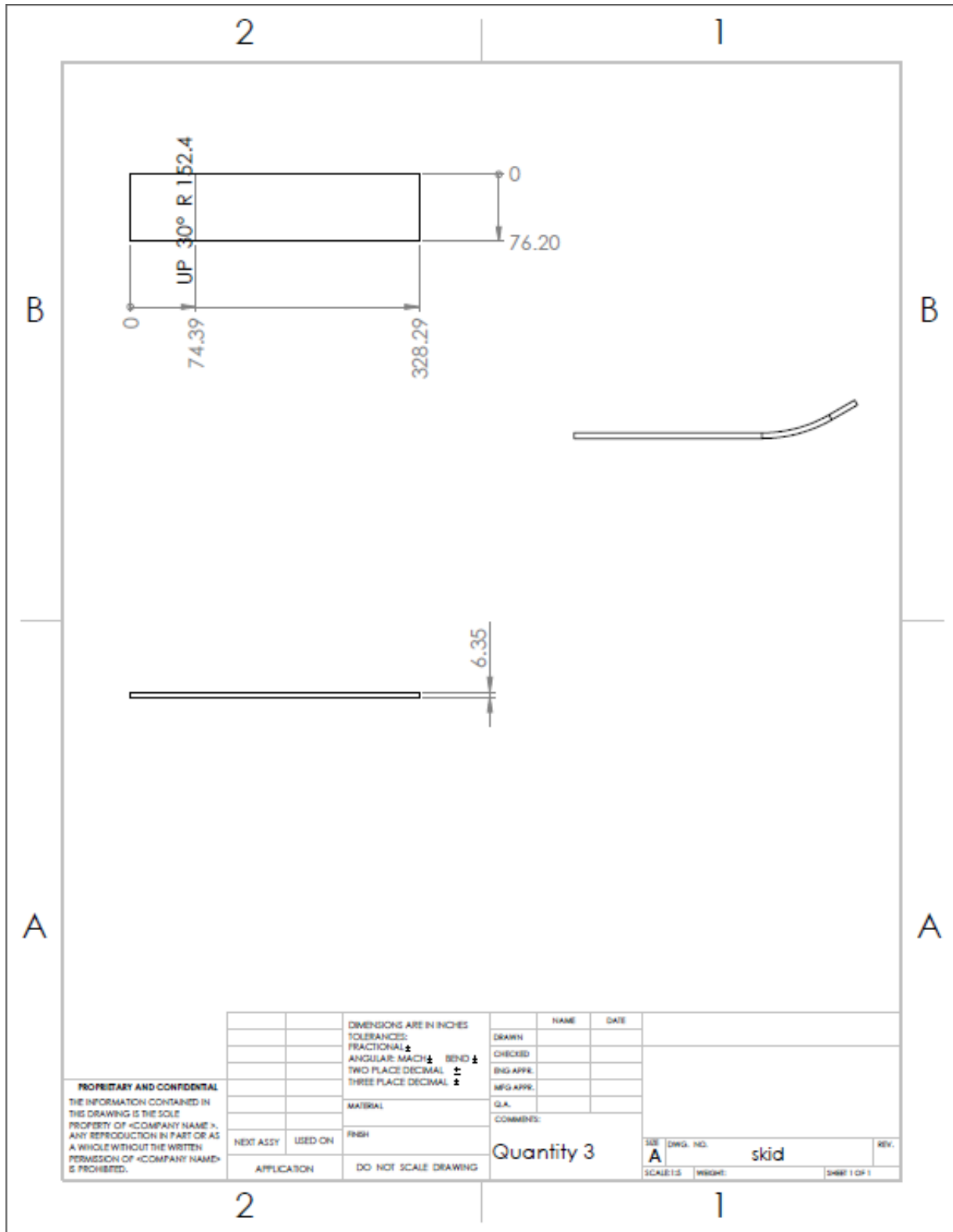

PROPRIETARY AND CONFIDENTIAL
 THE INFORMATION CONTAINED IN THIS DRAWING IS THE SOLE PROPERTY OF <COMPANY NAME>. ANY REPRODUCTION IN PART OR AS A WHOLE WITHOUT THE WRITTEN PERMISSION OF <COMPANY NAME> IS PROHIBITED.

| | | | | | |
|-------------|---------|--------------------------|--|--------------|----------|
| | | DIMENSIONS ARE IN INCHES | | NAME | DATE |
| | | TOLERANCES: | | DRAWN | |
| | | FRACTIONAL ± | | CHECKED | |
| | | ANGULAR: MATCH ± BEND ± | | ENG APPR. | |
| | | TWO PLACE DECIMAL ± | | MFG APPR. | |
| | | THREE PLACE DECIMAL ± | | Q.A. | |
| | | MATERIAL | | COMMENTS: | |
| NEXT ASSY | USED ON | FINISH | | Quantity 3 | |
| APPLICATION | | DO NOT SCALE DRAWING | | SIZE | DWG. NO. |
| | | | | A | skid |
| | | | | SCALE: 1:1 | WEIGHT: |
| | | | | SHEET 1 OF 1 | |

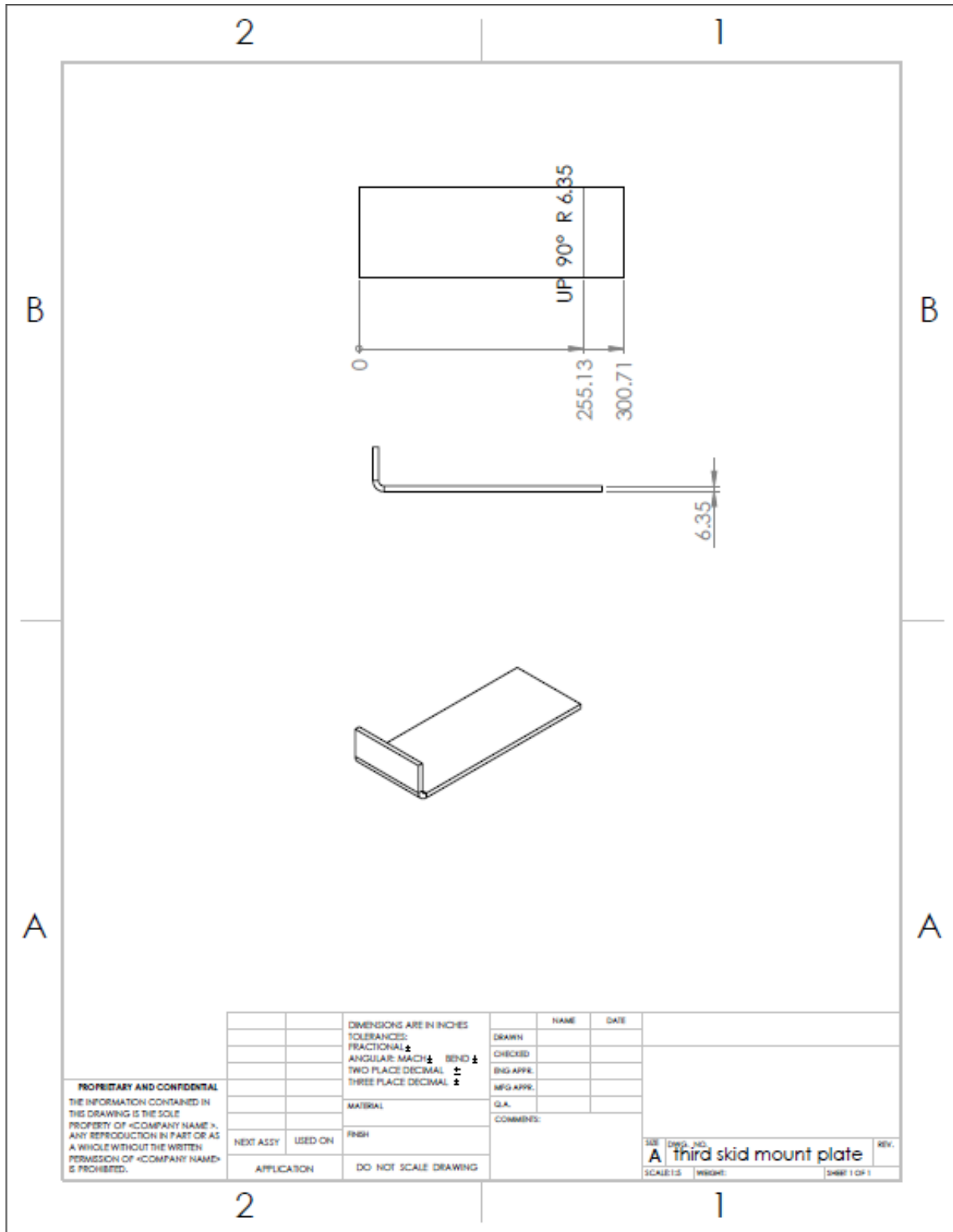

PROPRIETARY AND CONFIDENTIAL
 THE INFORMATION CONTAINED IN THIS DRAWING IS THE SOLE PROPERTY OF <COMPANY NAME>. ANY REPRODUCTION IN PART OR AS A WHOLE WITHOUT THE WRITTEN PERMISSION OF <COMPANY NAME> IS PROHIBITED.

| | | | | | |
|-------------|---------|--------------------------|--|---|------|
| | | DIMENSIONS ARE IN INCHES | | NAME | DATE |
| | | TOLERANCES: | | DRAWN | |
| | | FRACTIONAL ± | | CHECKED | |
| | | ANGULAR: MATCH ± BEND ± | | ENG APPR. | |
| | | TWO PLACE DECIMAL ± | | MFG APPR. | |
| | | THREE PLACE DECIMAL ± | | Q.A. | |
| | | MATERIAL | | COMMENTS: | |
| NEXT ASSY | USED ON | FINISH | | JOB | |
| APPLICATION | | DO NOT SCALE DRAWING | | Dept. NO. A third skid mount plate SCALE: 1:1 WEIGHT: SHEET 1 OF 1 | |

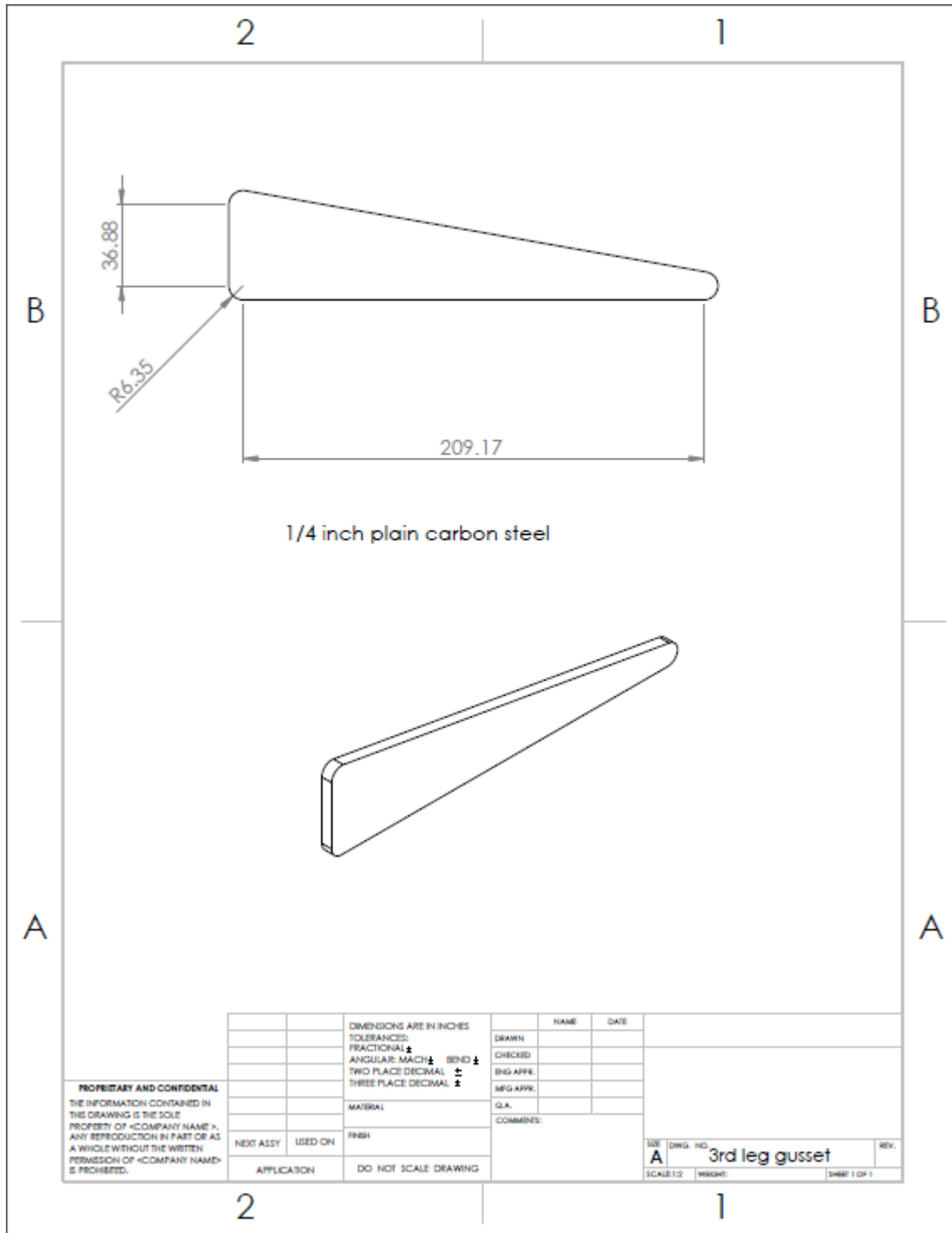

| | | | | | |
|---|---------|--------------------------|--|-----------|--------------|
| PROPRIETARY AND CONFIDENTIAL THE INFORMATION CONTAINED IN THIS DRAWING IS THE SOLE PROPERTY OF *COMPANY NAME*. ANY REPRODUCTION IN PART OR AS A WHOLE WITHOUT THE WRITTEN PERMISSION OF *COMPANY NAME* IS PROHIBITED. | | DIMENSIONS ARE IN INCHES | | NAME | DATE |
| | | TOLERANCES: | | DRAWN | |
| | | FRACTIONAL ± | DECIMAL ± | CHECKED | |
| | | ANGULAR: MATCH ± | BEND ± | ENG APPR. | |
| | | TWO PLACE DECIMAL ± | MFG APPR. | | |
| | | THREE PLACE DECIMAL ± | Q.A. | | |
| | | MATERIAL | COMMENTS: | | |
| NEXT ASSY | USED ON | FINISH | | | |
| APPLICATION | | DO NOT SCALE DRAWING | SIZE: A DWG. NO: 3rd leg gusset REV. | | |
| | | | SCALE: 1:1 | WEIGHT: | SHEET 1 OF 1 |

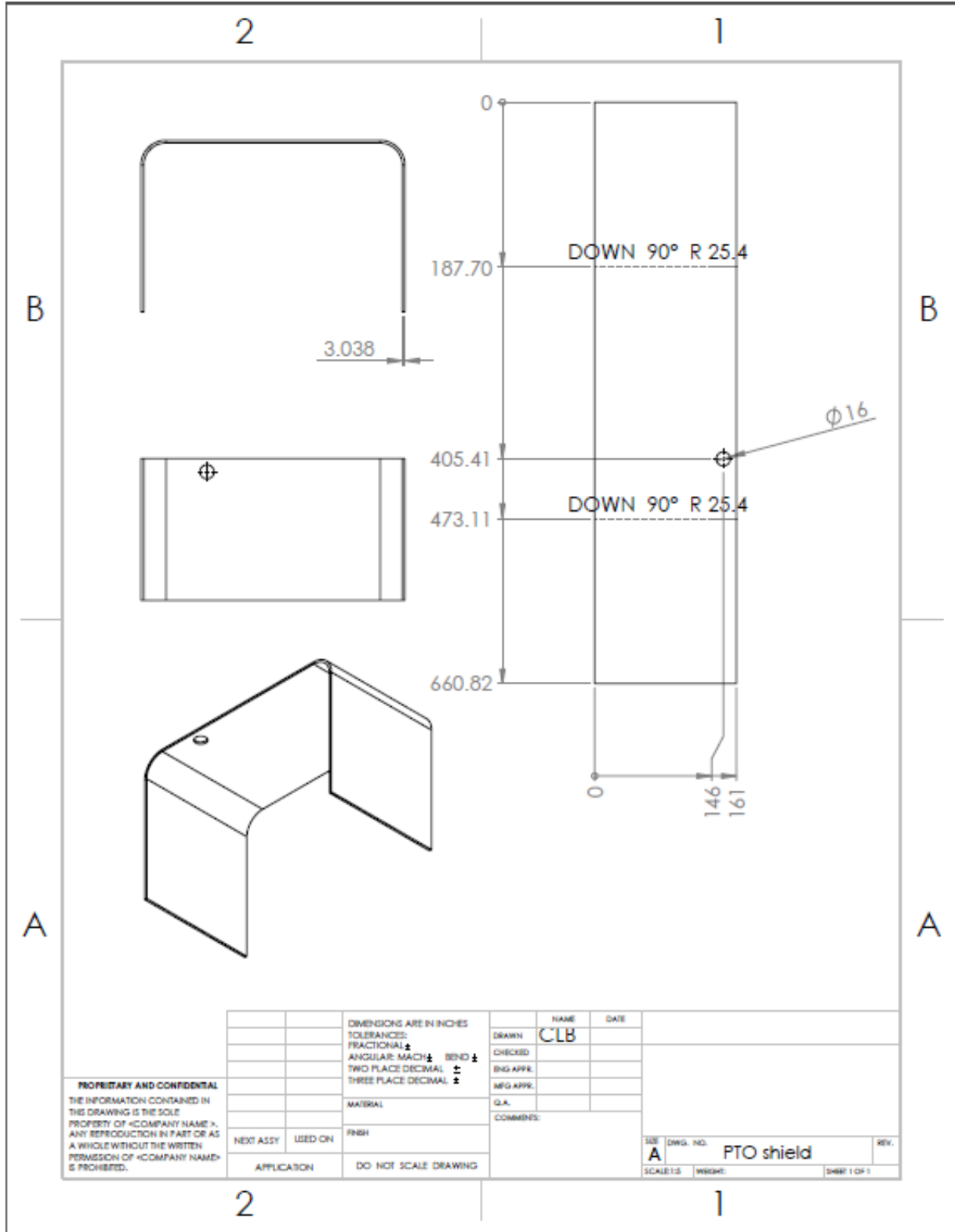

PROPRIETARY AND CONFIDENTIAL
 THE INFORMATION CONTAINED IN THIS DRAWING IS THE SOLE PROPERTY OF <COMPANY NAME>. ANY REPRODUCTION IN PART OR AS A WHOLE WITHOUT THE WRITTEN PERMISSION OF <COMPANY NAME> IS PROHIBITED.

| | | | | | |
|-------------|----------------------|--------------------------------|--|------------|--------------|
| | | DIMENSIONS ARE IN INCHES | | NAME | DATE |
| | | TOLERANCES: | | DRAWN | CLB |
| | | FRACTIONAL \pm | | CHECKED | |
| | | ANGULAR: MACH \pm BEND \pm | | ENG APPR. | |
| | | TWO PLACE DECIMAL \pm | | MFG APPR. | |
| | | THREE PLACE DECIMAL \pm | | Q.A. | |
| | | MATERIAL | | COMMENTS: | |
| NEXT ASSY | USED ON | FINISH | | SIZE | DWG. NO. |
| APPLICATION | DO NOT SCALE DRAWING | | | A | PTO shield |
| | | | | SCALE: 1:1 | REV. |
| | | | | WEIGHT: | SHEET 1 OF 1 |

Speed Sensor Pickup Plate (units in inches) (designed by Mr. Wayne Kiner)

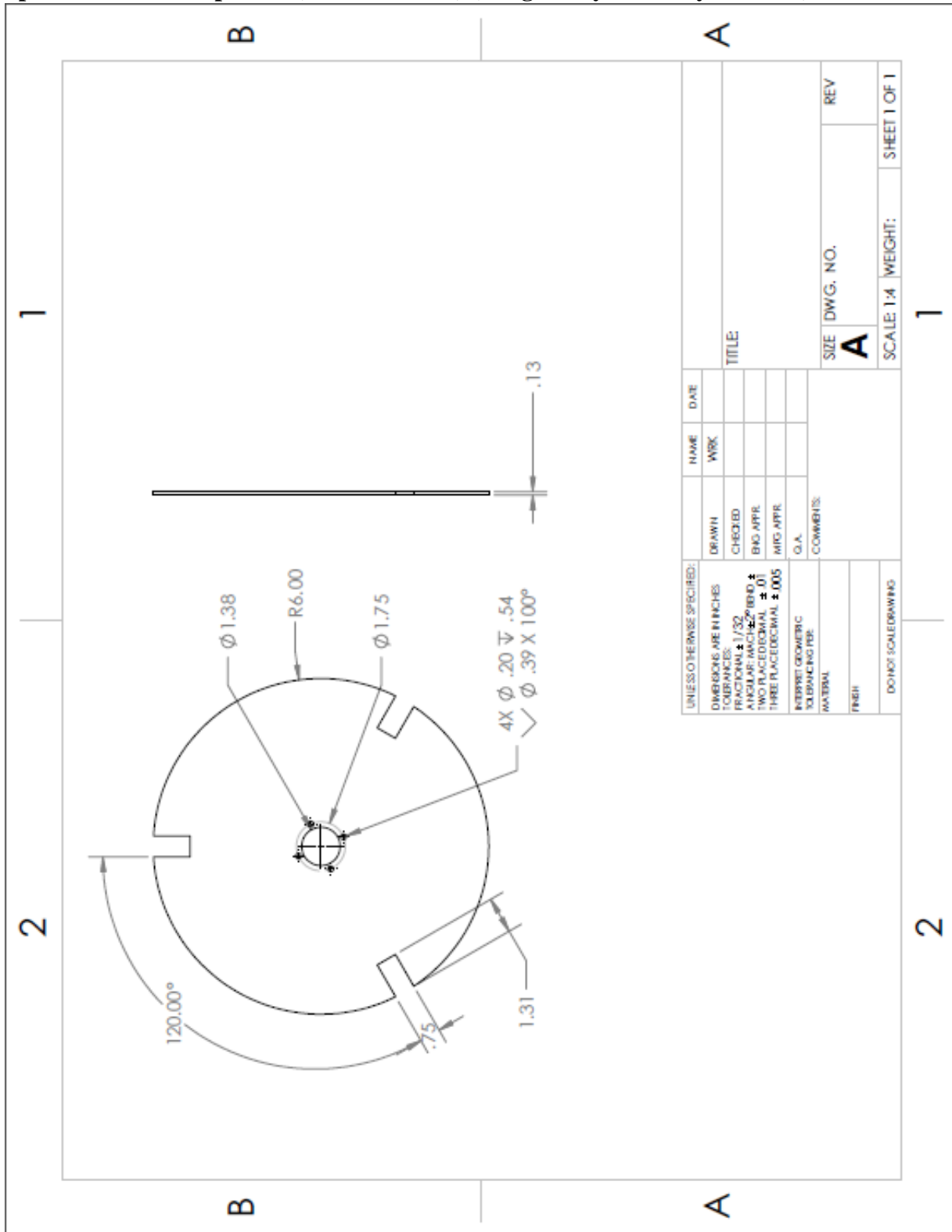

| UNLESS OTHERWISE SPECIFIED: | | NAME | DATE |
|-------------------------------------|--|------------|------|
| DIMENSIONS ARE IN INCHES | | DRWN | |
| TOLERANCES: | | CHKD | |
| FRACTIONAL ± 1/32 | | ENG. APPR. | |
| ANGULAR (MACH) ± 2' 00" | | MFG. APPR. | |
| TWO PLACE DECIMAL ± .01 | | G.A. | |
| THREE PLACE DECIMAL ± .005 | | COMMENTS: | |
| INTERPRET GEOMETRIC TOLERANCING PER | | | |
| MATERIAL | | | |
| FINISH | | | |
| DO NOT SCALE DRAWING | | | |

| | | |
|----------|----------|-----|
| SIZE | DWG. NO. | REV |
| A | | |

| | | |
|------------|---------|--------------|
| SCALE: 1:4 | WEIGHT: | SHEET 1 OF 1 |
| | | |

Hydraulic Mounts (units in mm)

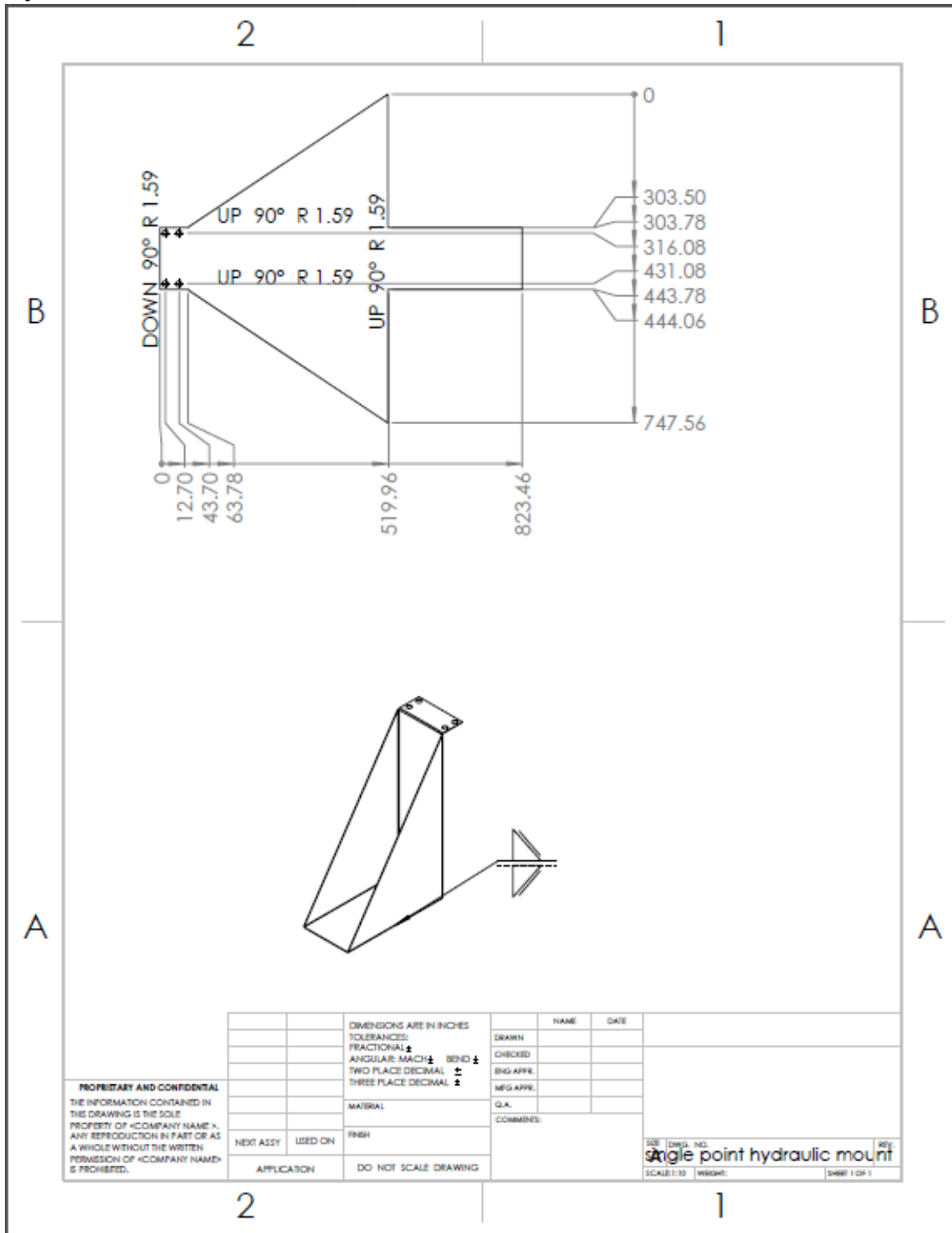

| <p>PROPRIETARY AND CONFIDENTIAL THE INFORMATION CONTAINED IN THIS DRAWING IS THE SOLE PROPERTY OF <COMPANY NAME>. ANY REPRODUCTION IN PART OR AS A WHOLE WITHOUT THE WRITTEN PERMISSION OF <COMPANY NAME> IS PROHIBITED.</p> | | <p>DIMENSIONS ARE IN INCHES TOLERANCES: FRACTIONAL: \pm ANGULAR: MACH \pm BEND \pm TWO PLACE DECIMAL \pm THREE PLACE DECIMAL \pm</p> | <table border="1"> <thead> <tr> <th>NAME</th> <th>DATE</th> </tr> </thead> <tbody> <tr> <td>DRAWN</td> <td></td> </tr> <tr> <td>CHECKED</td> <td></td> </tr> <tr> <td>ENG APPR.</td> <td></td> </tr> <tr> <td>MFG APPR.</td> <td></td> </tr> <tr> <td>G.A.</td> <td></td> </tr> </tbody> </table> | NAME | DATE | DRAWN | | CHECKED | | ENG APPR. | | MFG APPR. | | G.A. | | <p>SCALE: 1:10 WEIGHT: SHEET 1 OF 1</p> |
|---|---------------|---|---|------|------|-------|--|---------|--|-----------|--|-----------|--|------|--|---|
| NAME | DATE | | | | | | | | | | | | | | | |
| DRAWN | | | | | | | | | | | | | | | | |
| CHECKED | | | | | | | | | | | | | | | | |
| ENG APPR. | | | | | | | | | | | | | | | | |
| MFG APPR. | | | | | | | | | | | | | | | | |
| G.A. | | | | | | | | | | | | | | | | |
| <p>NEXT ASSY USED ON</p> | <p>FINISH</p> | <p>COMMENTS:</p> | <p>single point hydraulic mount</p> | | | | | | | | | | | | | |
| <p>APPLICATION DO NOT SCALE DRAWING</p> | | | | | | | | | | | | | | | | |

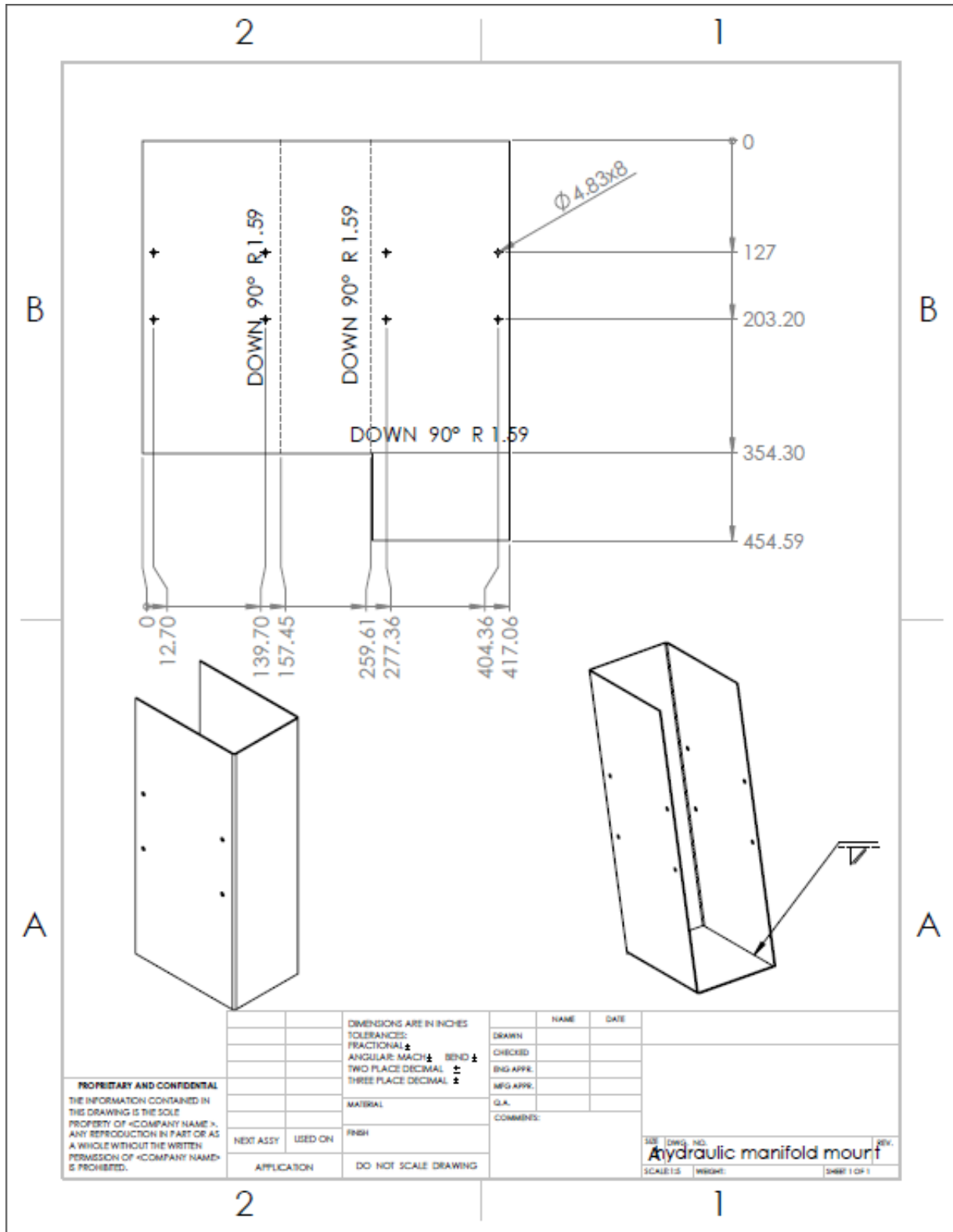

PROPRIETARY AND CONFIDENTIAL
 THE INFORMATION CONTAINED IN THIS DRAWING IS THE SOLE PROPERTY OF <COMPANY NAME>. ANY REPRODUCTION IN PART OR AS A WHOLE WITHOUT THE WRITTEN PERMISSION OF <COMPANY NAME> IS PROHIBITED.

| | | | | | |
|-------------|---------|--------------------------------|--|---|------|
| | | DIMENSIONS ARE IN INCHES | | NAME | DATE |
| | | TOLERANCES: | | DRAWN | |
| | | FRACTIONAL \pm | | CHECKED | |
| | | ANGULAR MATCH \pm BEND \pm | | ENG APPR. | |
| | | TWO PLACE DECIMAL \pm | | MFG APPR. | |
| | | THREE PLACE DECIMAL \pm | | Q.A. | |
| | | MATERIAL | | COMMENTS: | |
| NEXT ASSY | USED ON | FINISH | | DATE | |
| APPLICATION | | DO NOT SCALE DRAWING | | SCALE: 1:1 | |
| | | | | Dwg. No. Hydraulic manifold mount SCALE: 1:1 WEIGHT: SHEET 1 OF 1 | |

Assembly Drawings (units in mm)

The drawing shows an isometric view of a mechanical assembly. Callout '1' points to the main horizontal frame. Callout '2' points to a vertical support structure on the left. Callout 'A' points to the base assembly with wheels. Callout 'B' points to the upper mechanism and sensors.

| | | | | |
|-------------|----------------------|--------------------------|---------------------------|-------------------------|
| | | DIMENSIONS ARE IN INCHES | NAME | DATE |
| | | TOLERANCES: | DRAWN | |
| | | FRACTIONAL ± | CHECKED | |
| | | ANGULAR MATCH ± BEND ± | ENG APPR. | |
| | | TWO PLACE DECIMAL ± | MFG APPR. | |
| | | THREE PLACE DECIMAL ± | G.A. | |
| | | MATERIAL | COMMENTS: | |
| NEXT ASSY | USED ON | FINISH | SITE DWG. NO. REV. | |
| APPLICATION | DO NOT SCALE DRAWING | | Fully assembled test mule | |
| | | | SCALE:1:50 | WEIGHT: SHEET 1 OF 13 |

PROPRIETARY AND CONFIDENTIAL
 THE INFORMATION CONTAINED IN THIS DRAWING IS THE SOLE PROPERTY OF <COMPANY NAME>. ANY REPRODUCTION IN PART OR AS A WHOLE WITHOUT THE WRITTEN PERMISSION OF <COMPANY NAME> IS PROHIBITED.

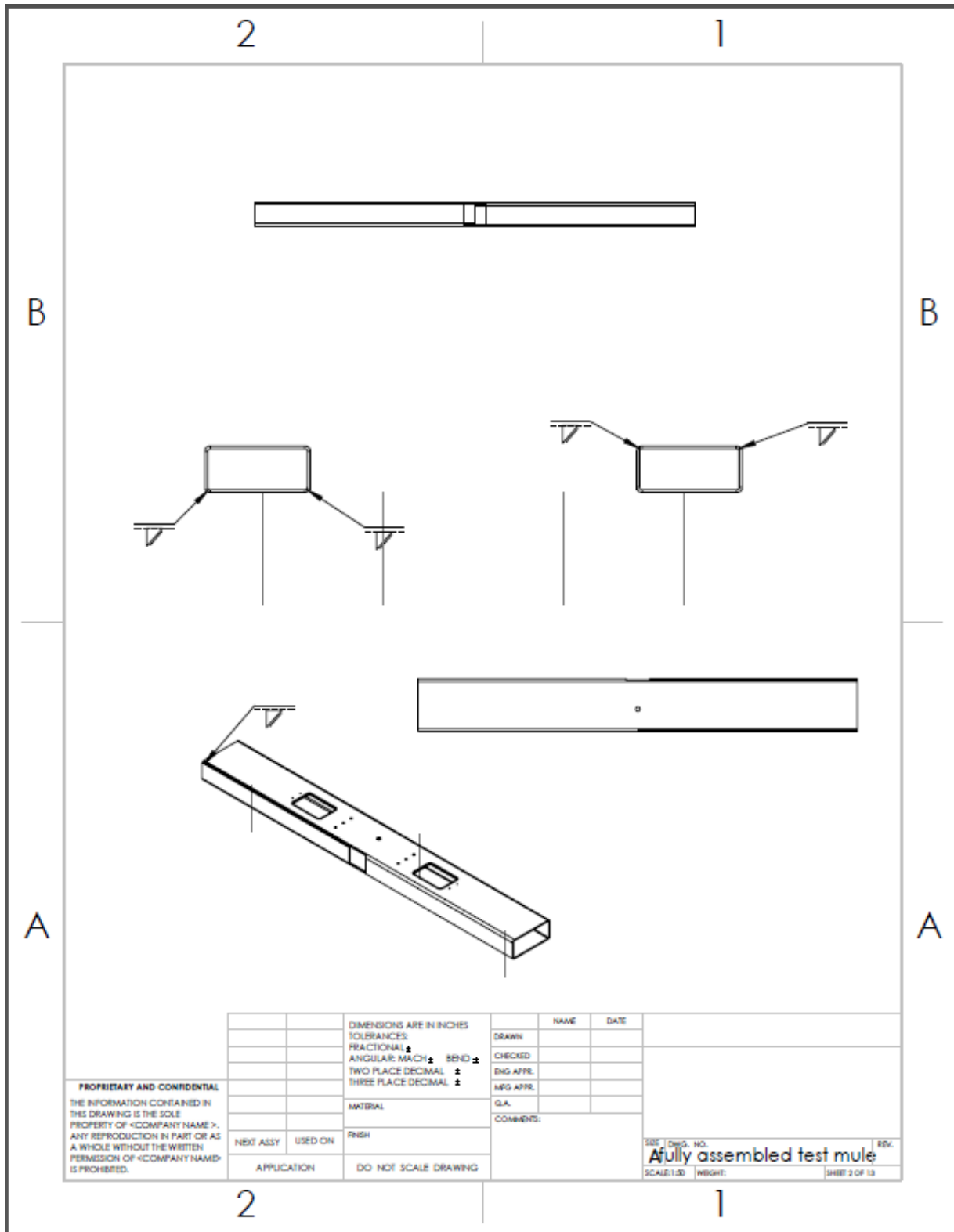

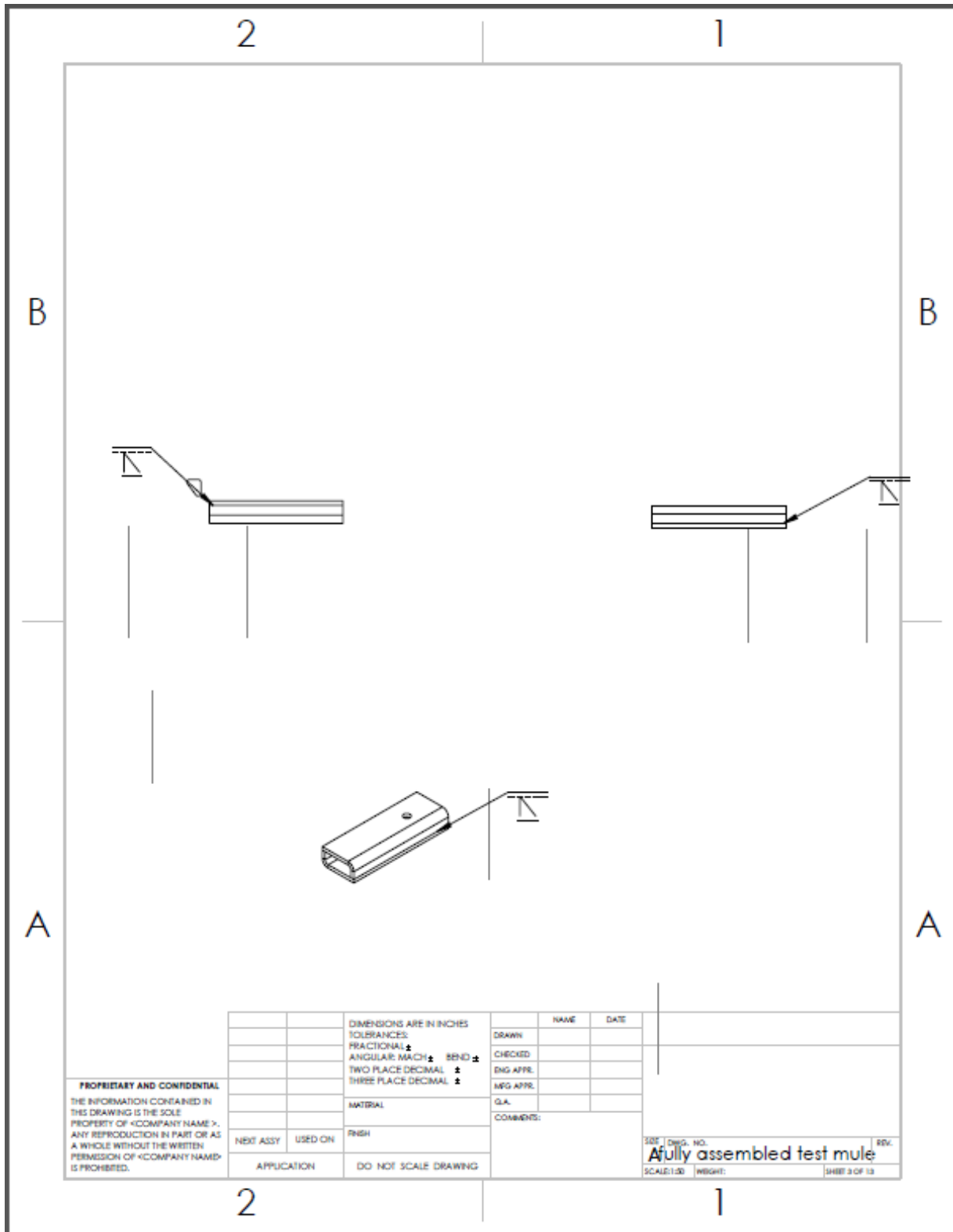

PROPRIETARY AND CONFIDENTIAL
 THE INFORMATION CONTAINED IN THIS DRAWING IS THE SOLE PROPERTY OF <COMPANY NAME>. ANY REPRODUCTION IN PART OR AS A WHOLE WITHOUT THE WRITTEN PERMISSION OF <COMPANY NAME> IS PROHIBITED.

| | | | | | | | | |
|-------------|--|--------------------------|--|---------------------------|--|---------------|--|------|
| | | DIMENSIONS ARE IN INCHES | | NAME | | DATE | | |
| | | TOLERANCES: | | DRAWN | | | | |
| | | FRACTIONAL ± | | CHECKED | | | | |
| | | ANGULAR: MACH ± BEND ± | | ENG APPR. | | | | |
| | | TWO PLACE DECIMAL ± | | MFG APPR. | | | | |
| | | THREE PLACE DECIMAL ± | | Q.A. | | | | |
| | | MATERIAL | | COMMENTS: | | | | |
| NEXT ASSY | | USED ON | | | | | | |
| APPLICATION | | DO NOT SCALE DRAWING | | SIZE | | DWG. NO. | | |
| | | | | SCALE:1:50 | | WEIGHT: | | |
| | | | | | | SHEET 2 OF 13 | | |
| | | | | Fully assembled test mule | | | | REV. |

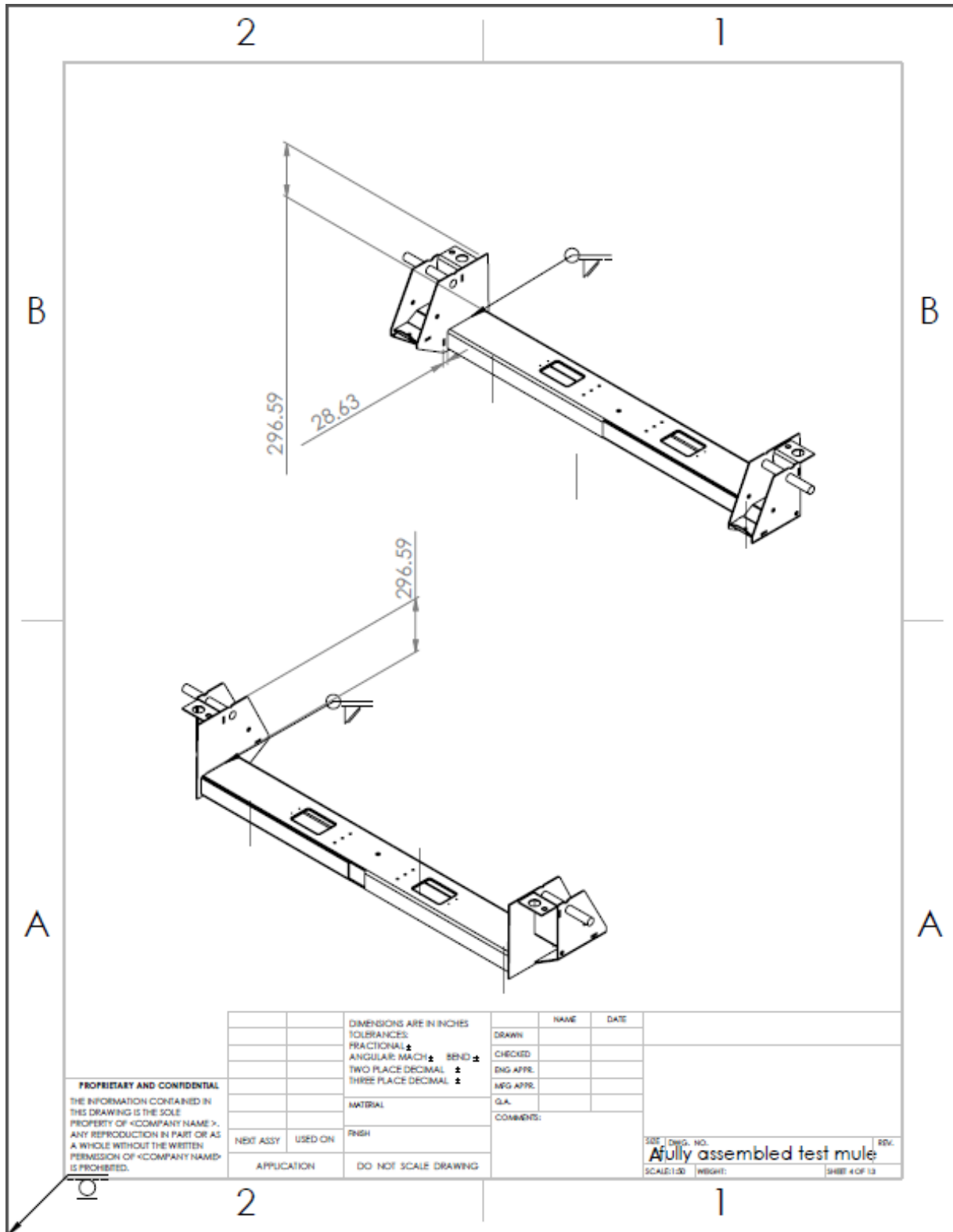

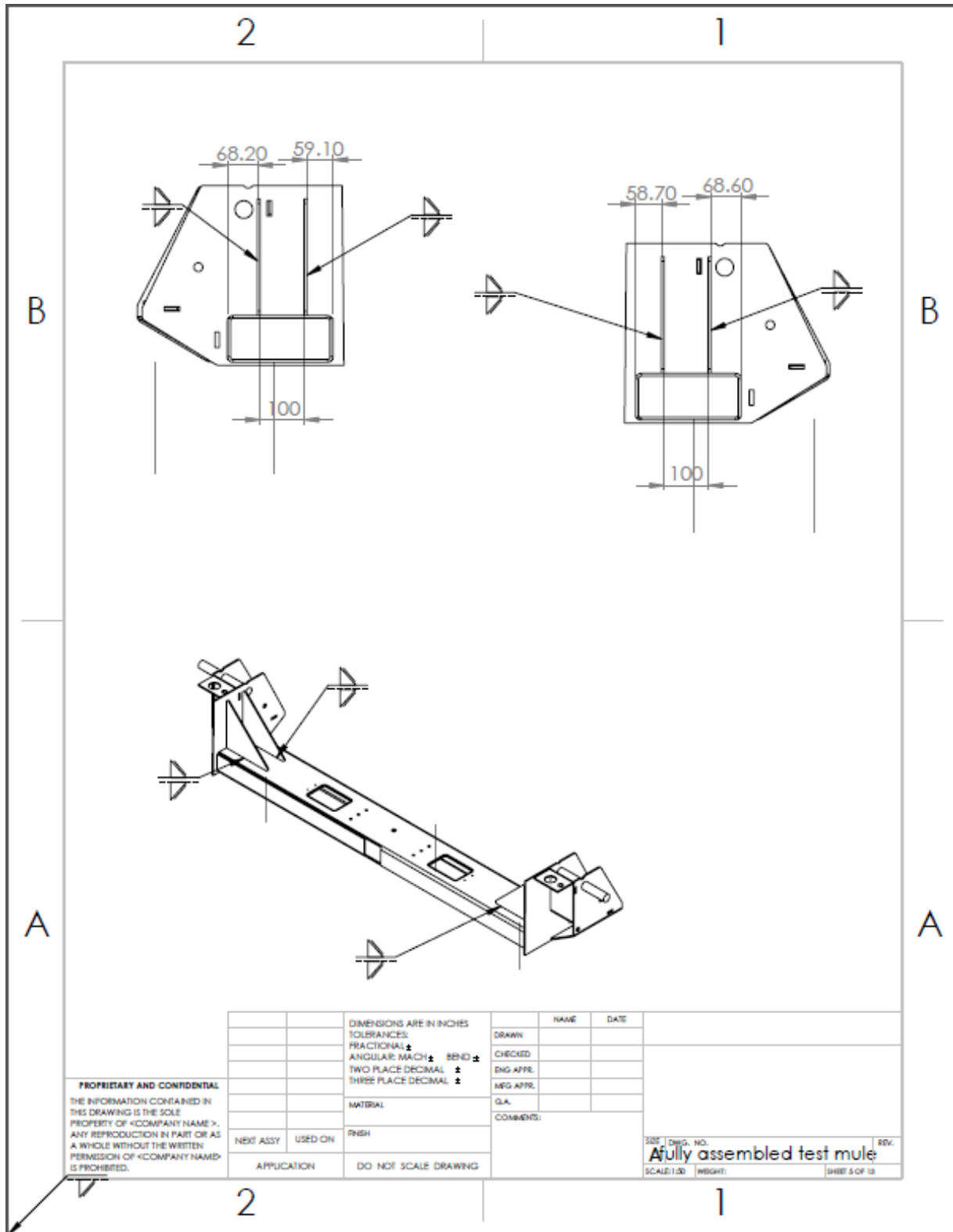

PROPRIETARY AND CONFIDENTIAL
 THE INFORMATION CONTAINED IN THIS DRAWING IS THE SOLE PROPERTY OF <COMPANY NAME>. ANY REPRODUCTION IN PART OR AS A WHOLE WITHOUT THE WRITTEN PERMISSION OF <COMPANY NAME> IS PROHIBITED.

| | | | | | |
|-------------|---------|--------------------------|--|--------------------------------------|------|
| | | DIMENSIONS ARE IN INCHES | | NAME | DATE |
| | | TOLERANCES: | | DRAWN | |
| | | FRACTIONAL ± | | CHECKED | |
| | | ANGULAR MATCH ± BEND ± | | ENG APPR. | |
| | | TWO PLACE DECIMAL ± | | MFG APPR. | |
| | | THREE PLACE DECIMAL ± | | Q.A. | |
| | | MATERIAL | | COMMENTS: | |
| NEXT ASSY | USED ON | FINISH | | SIZE Desig. No. REV. | |
| APPLICATION | | DO NOT SCALE DRAWING | | Fully assembled test mule | |
| | | | | SCALE:1:50 WEIGHT: SHEET 5 OF 13 | |

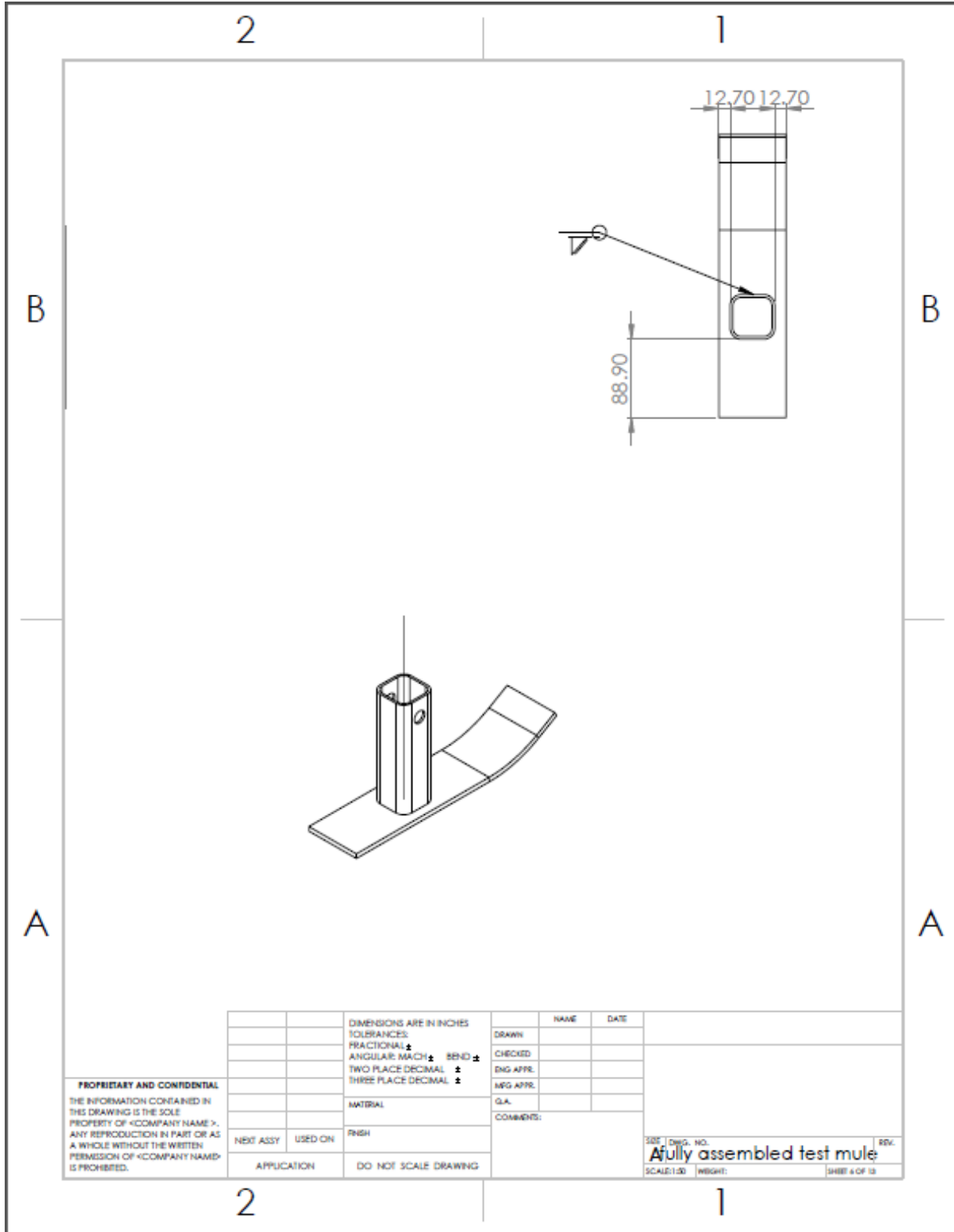

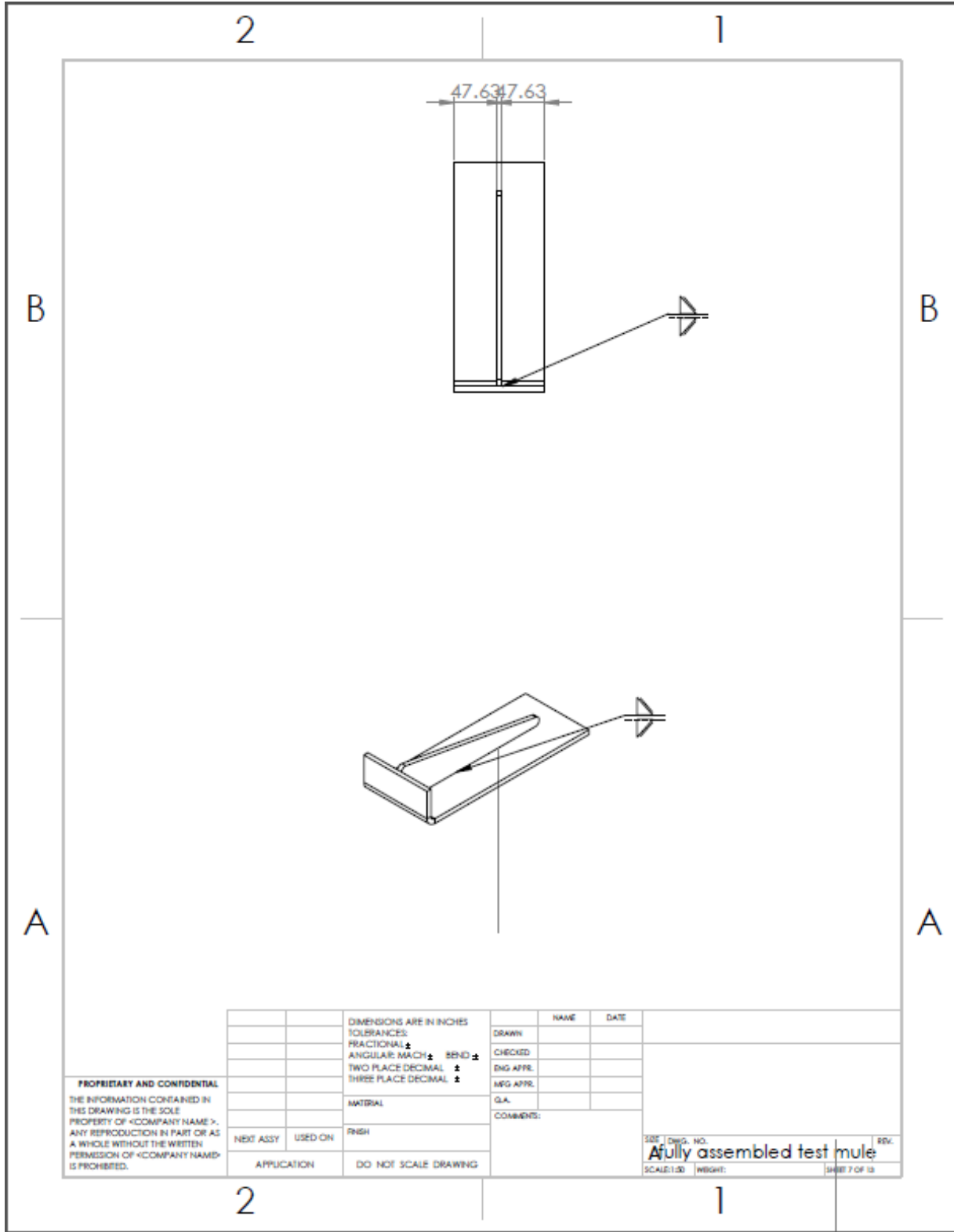

| | | | | | |
|---|--|---|--------------------------------|--|---|
| PROPRIETARY AND CONFIDENTIAL THE INFORMATION CONTAINED IN THIS DRAWING IS THE SOLE PROPERTY OF <COMPANY NAME>. ANY REPRODUCTION IN PART OR AS A WHOLE WITHOUT THE WRITTEN PERMISSION OF <COMPANY NAME> IS PROHIBITED. | | DIMENSIONS ARE IN INCHES TOLERANCES: FRACTIONAL ± ANGULAR: MACH ± BEND ± TWO PLACE DECIMAL ± THREE PLACE DECIMAL ± | | NAME DATE | |
| | | DRAWN CHECKED ENG APPR. MFG APPR. Q.A. | COMMENTS: | | |
| | | NEXT ASSY USED ON APPLICATION | FINISH DO NOT SCALE DRAWING | DES. NO. fully assembled test mule | REV. SCALE: 1:50 WEIGHT: SHEET 7 OF 13 |
| | | | | | |

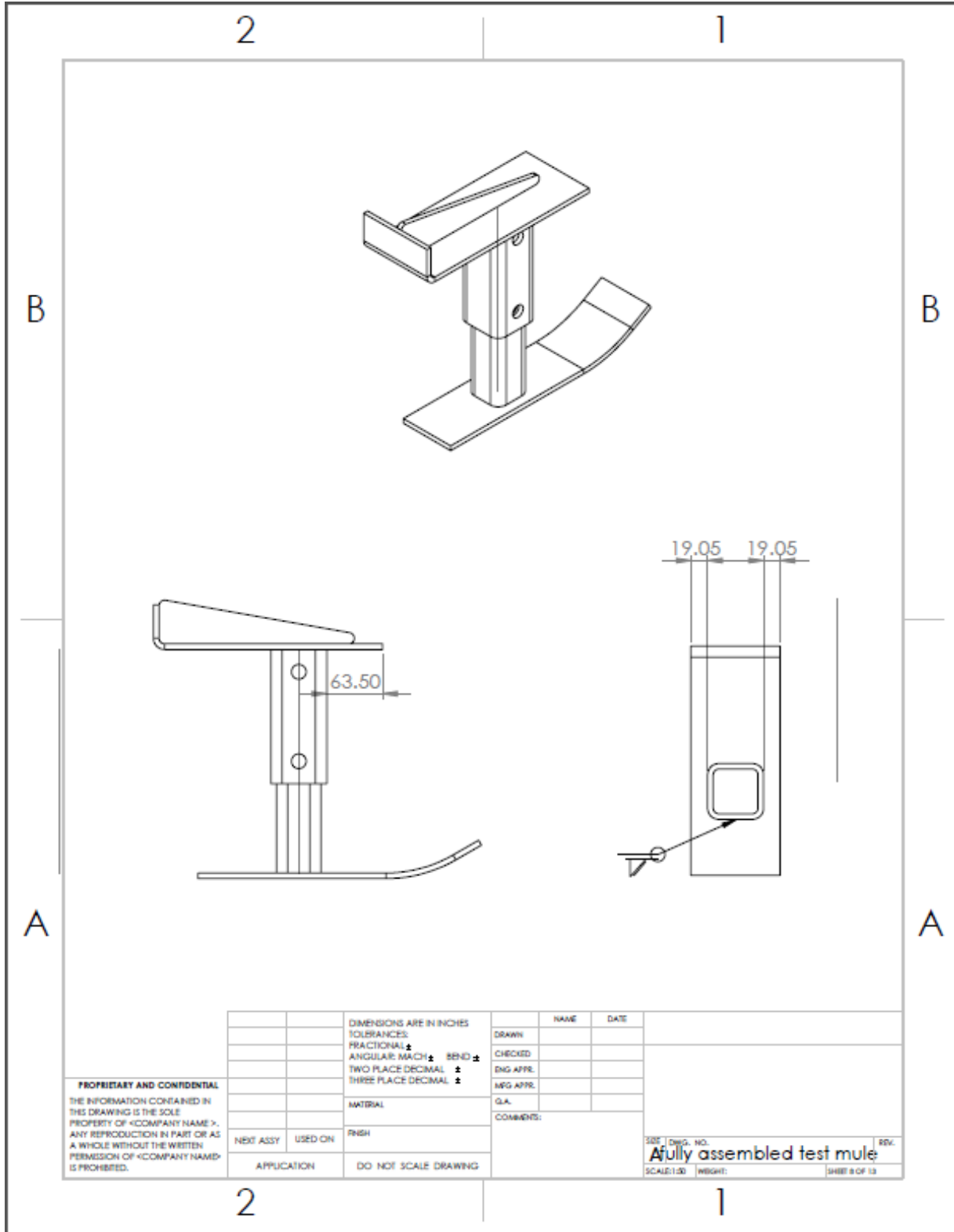

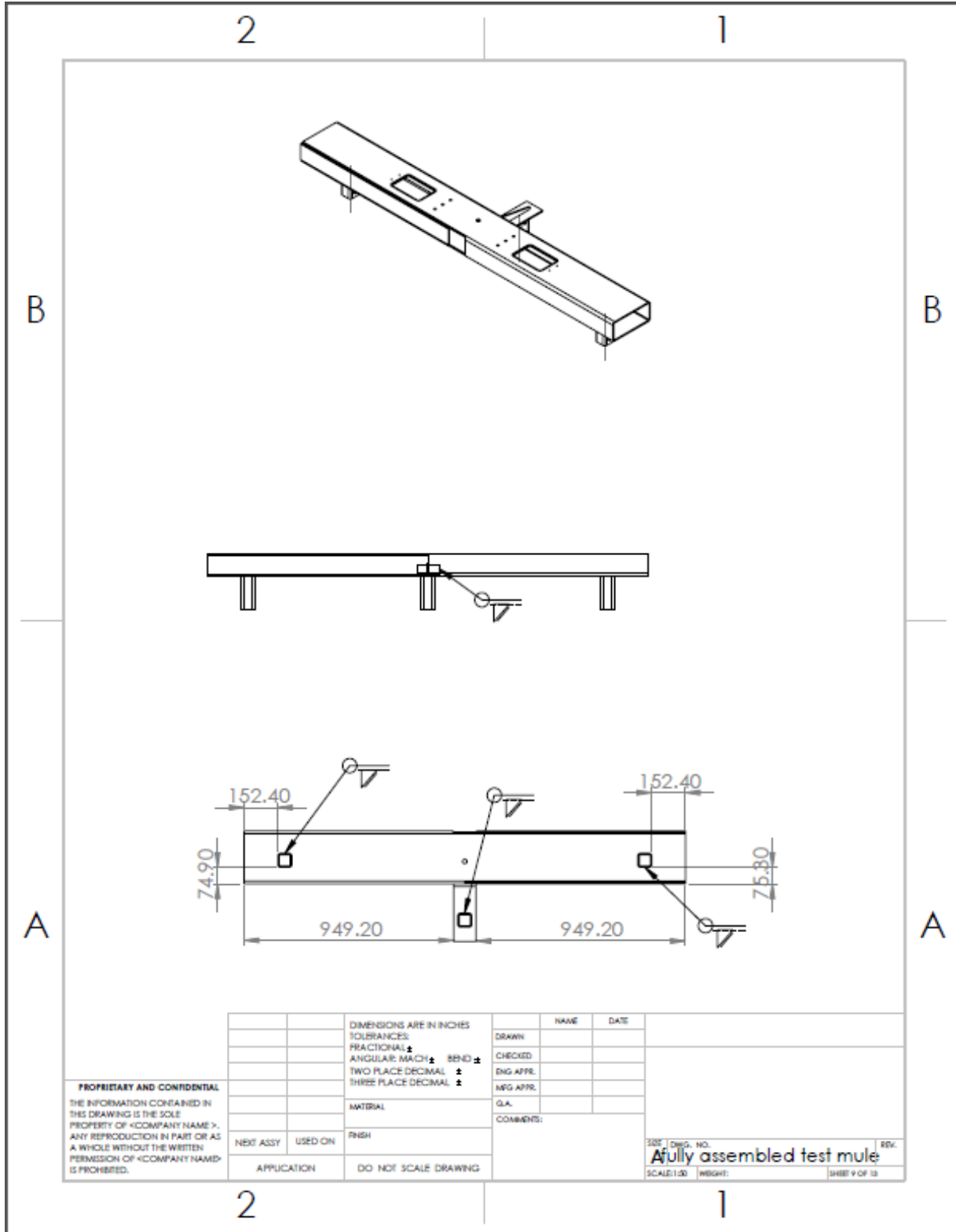

PROPRIETARY AND CONFIDENTIAL
 THE INFORMATION CONTAINED IN THIS DRAWING IS THE SOLE PROPERTY OF <COMPANY NAME>. ANY REPRODUCTION IN PART OR AS A WHOLE WITHOUT THE WRITTEN PERMISSION OF <COMPANY NAME> IS PROHIBITED.

| | | | | | |
|-------------|---------|--------------------------|--|--------------------------------------|------|
| | | DIMENSIONS ARE IN INCHES | | NAME | DATE |
| | | TOLERANCES: | | DRAWN | |
| | | FRACTIONAL ± | | CHECKED | |
| | | ANGULAR MATCH ± BEND ± | | ENG APPR. | |
| | | TWO PLACE DECIMAL ± | | MFG APPR. | |
| | | THREE PLACE DECIMAL ± | | Q.A. | |
| | | MATERIAL | | COMMENTS: | |
| NEXT ASSY | USED ON | FINISH | | SIZE Desig. No. REV. | |
| APPLICATION | | DO NOT SCALE DRAWING | | Fully assembled test mule | |
| | | | | SCALE:1:50 WEIGHT: SHEET 9 OF 13 | |

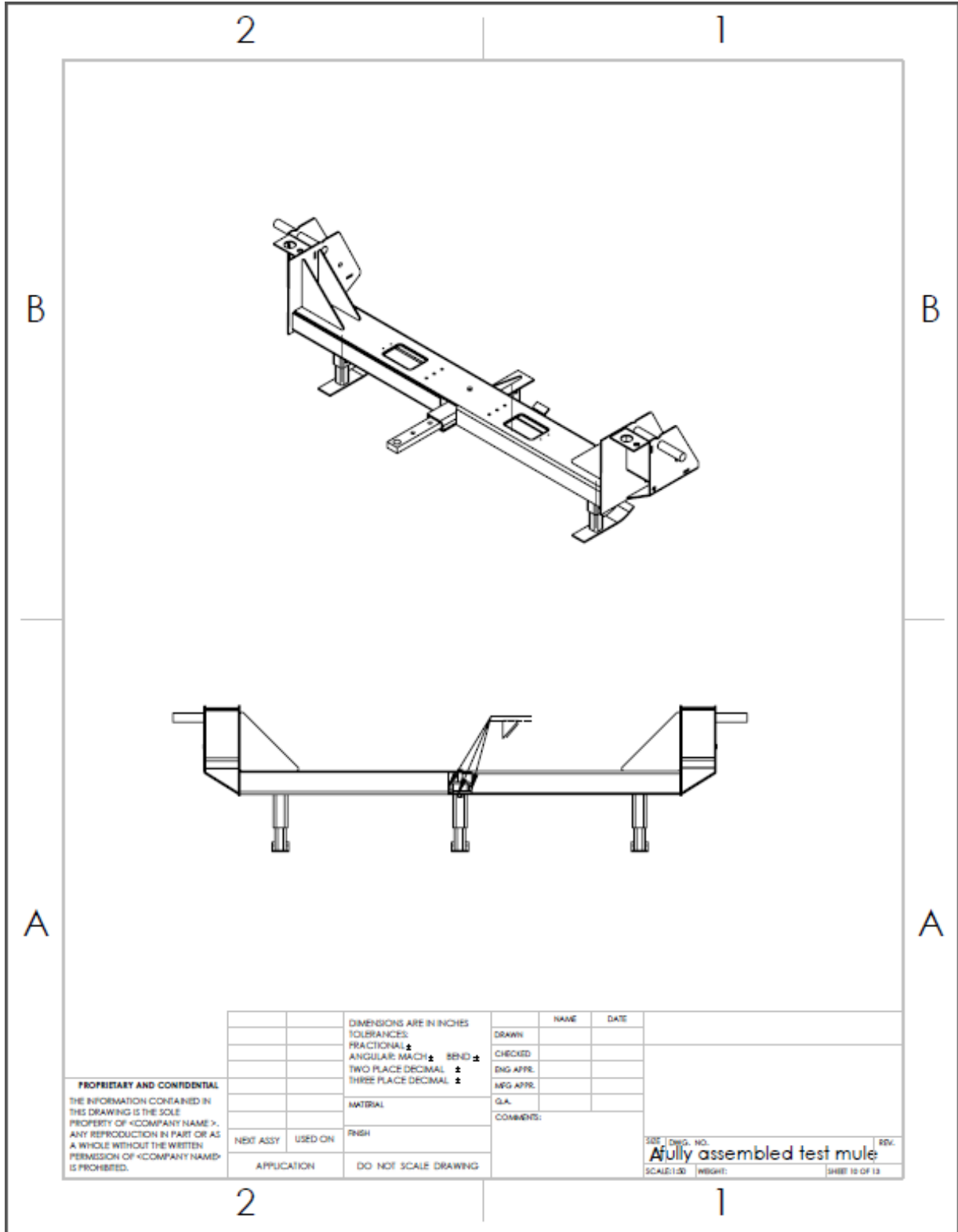

PROPRIETARY AND CONFIDENTIAL
 THE INFORMATION CONTAINED IN THIS DRAWING IS THE SOLE PROPERTY OF <COMPANY NAME>. ANY REPRODUCTION IN PART OR AS A WHOLE WITHOUT THE WRITTEN PERMISSION OF <COMPANY NAME> IS PROHIBITED.

| | | | | | |
|-------------|---------|--------------------------|--|---------------------------|--------------------------|
| | | DIMENSIONS ARE IN INCHES | | NAME | DATE |
| | | TOLERANCES: | | DRAWN | |
| | | FRACTIONAL ± | | CHECKED | |
| | | ANGULAR MATCH ± BEND ± | | ENG APPR. | |
| | | TWO PLACE DECIMAL ± | | MFG APPR. | |
| | | THREE PLACE DECIMAL ± | | Q.A. | |
| | | MATERIAL | | COMMENTS: | |
| NEXT ASSY | USED ON | FINISH | | SIZE Desig. No. REV. | |
| APPLICATION | | DO NOT SCALE DRAWING | | Fully assembled test mule | |
| | | | | SCALE:1:50 | WEIGHT: SHEET 12 OF 13 |

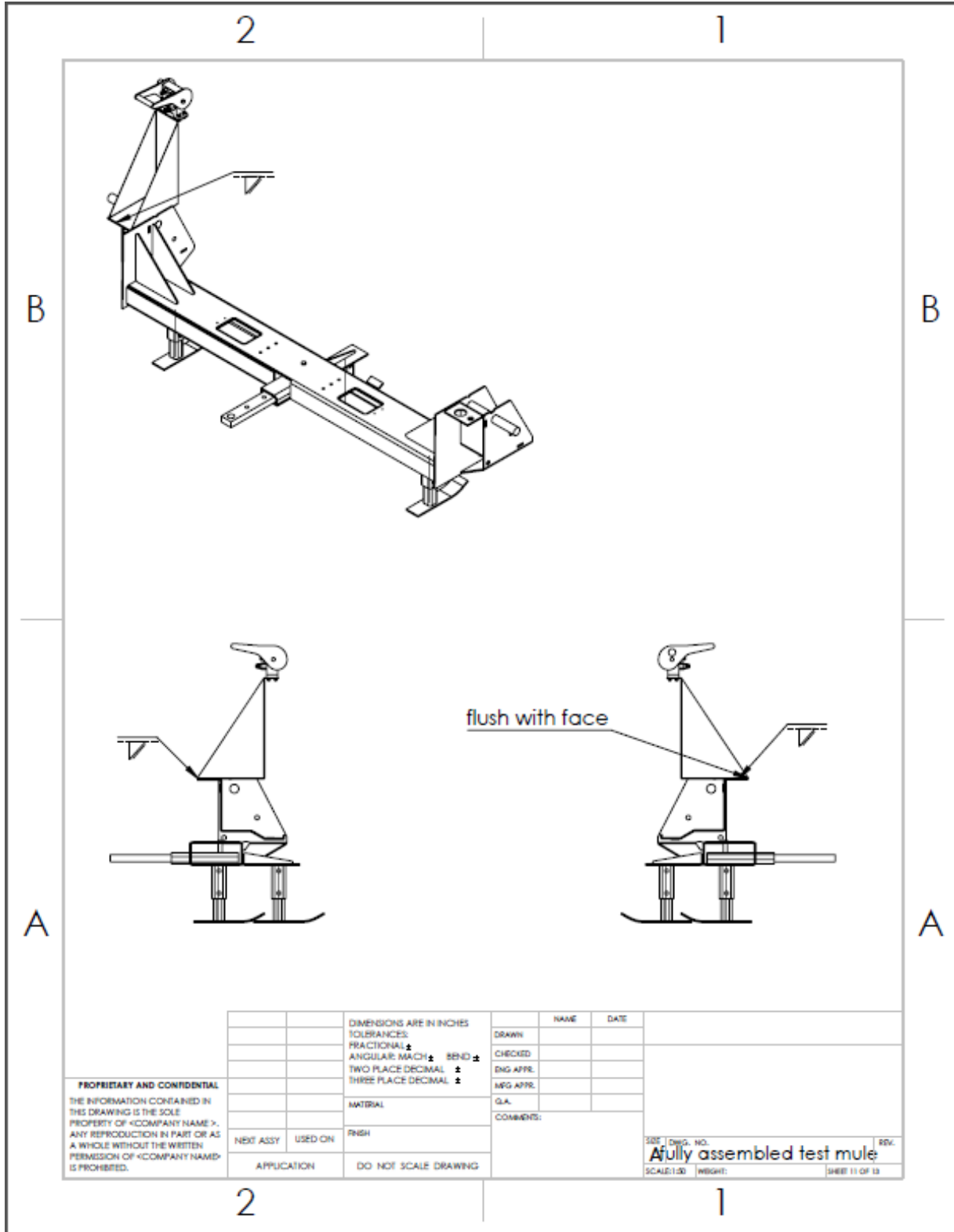

| | | | | | |
|---|--|---|----------------|--|--------------|
| <p>PROPRIETARY AND CONFIDENTIAL THE INFORMATION CONTAINED IN THIS DRAWING IS THE SOLE PROPERTY OF <COMPANY NAME>. ANY REPRODUCTION IN PART OR AS A WHOLE WITHOUT THE WRITTEN PERMISSION OF <COMPANY NAME> IS PROHIBITED.</p> | | <p>DIMENSIONS ARE IN INCHES TOLERANCES: FRACTIONAL ± ANGULAR MATCH ± BEND ± TWO PLACE DECIMAL ± THREE PLACE DECIMAL ±</p> | | NAME | DATE |
| | | <p>NEXT ASSY</p> | <p>USED ON</p> | <p>FINISH</p> | <p>DRAWN</p> |
| <p>APPLICATION</p> | | <p>DO NOT SCALE DRAWING</p> | | <p>CHECKED</p> | |
| | | <p>MATERIAL</p> | | <p>ENG APPR.</p> | |
| | | | | <p>MFG APPR.</p> | |
| | | | | <p>Q.A.</p> | |
| | | | | <p>COMMENTS:</p> | |
| | | | | <p>SIZE Desig. No. REV. fully assembled test mule</p> | |
| | | | | <p>SCALE:1:50 WEIGHT: SHEET 11 OF 13</p> | |

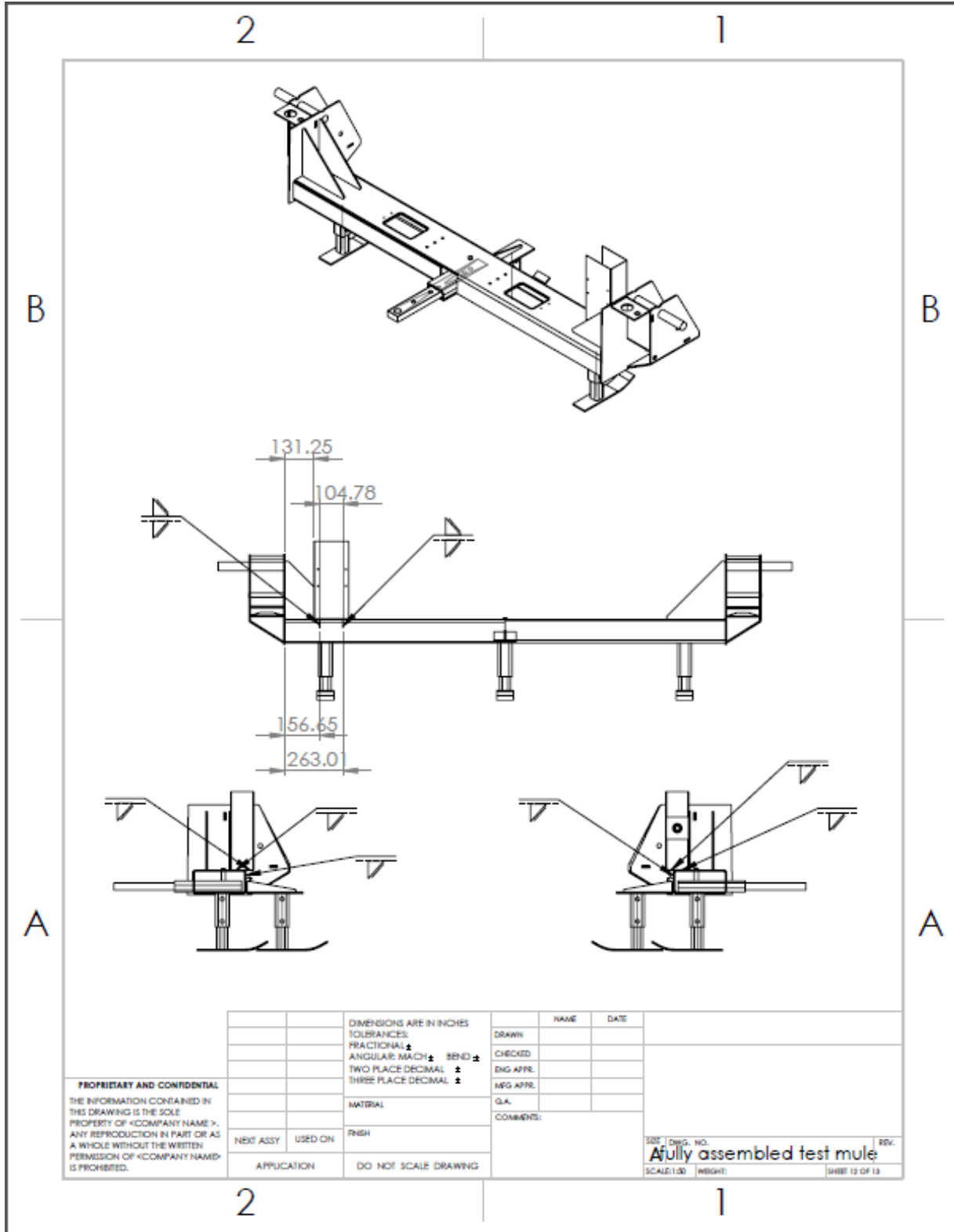

| | | | | | | | | | |
|---|--|---|----------------|------------------|--------------|--------------------|------------------|------------------|-----------------------|
| <p>PROPRIETARY AND CONFIDENTIAL THE INFORMATION CONTAINED IN THIS DRAWING IS THE SOLE PROPERTY OF <COMPANY NAME>. ANY REPRODUCTION IN PART OR AS A WHOLE WITHOUT THE WRITTEN PERMISSION OF <COMPANY NAME> IS PROHIBITED.</p> | | <p>DIMENSIONS ARE IN INCHES TOLERANCES: FRACTIONAL ± ANGULAR MATCH ± BEND ± TWO PLACE DECIMAL ± THREE PLACE DECIMAL ±</p> | | <p>NAME</p> | <p>DATE</p> | | | | |
| | | <p>NEXT ASSY</p> | <p>USED ON</p> | <p>FINISH</p> | <p>DRAWN</p> | <p>CHECKED</p> | <p>ENG APPR.</p> | <p>MFG APPR.</p> | <p>Q.A.</p> |
| <p>APPLICATION</p> | | <p>DO NOT SCALE DRAWING</p> | | <p>COMMENTS:</p> | | <p>SCALE: 1:50</p> | | <p>WEIGHT:</p> | <p>SHEET 12 OF 13</p> |

REV. 1
 Desg. NO. Fully assembled test mule
 SCALE: 1:50 WEIGHT: SHEET 12 OF 13

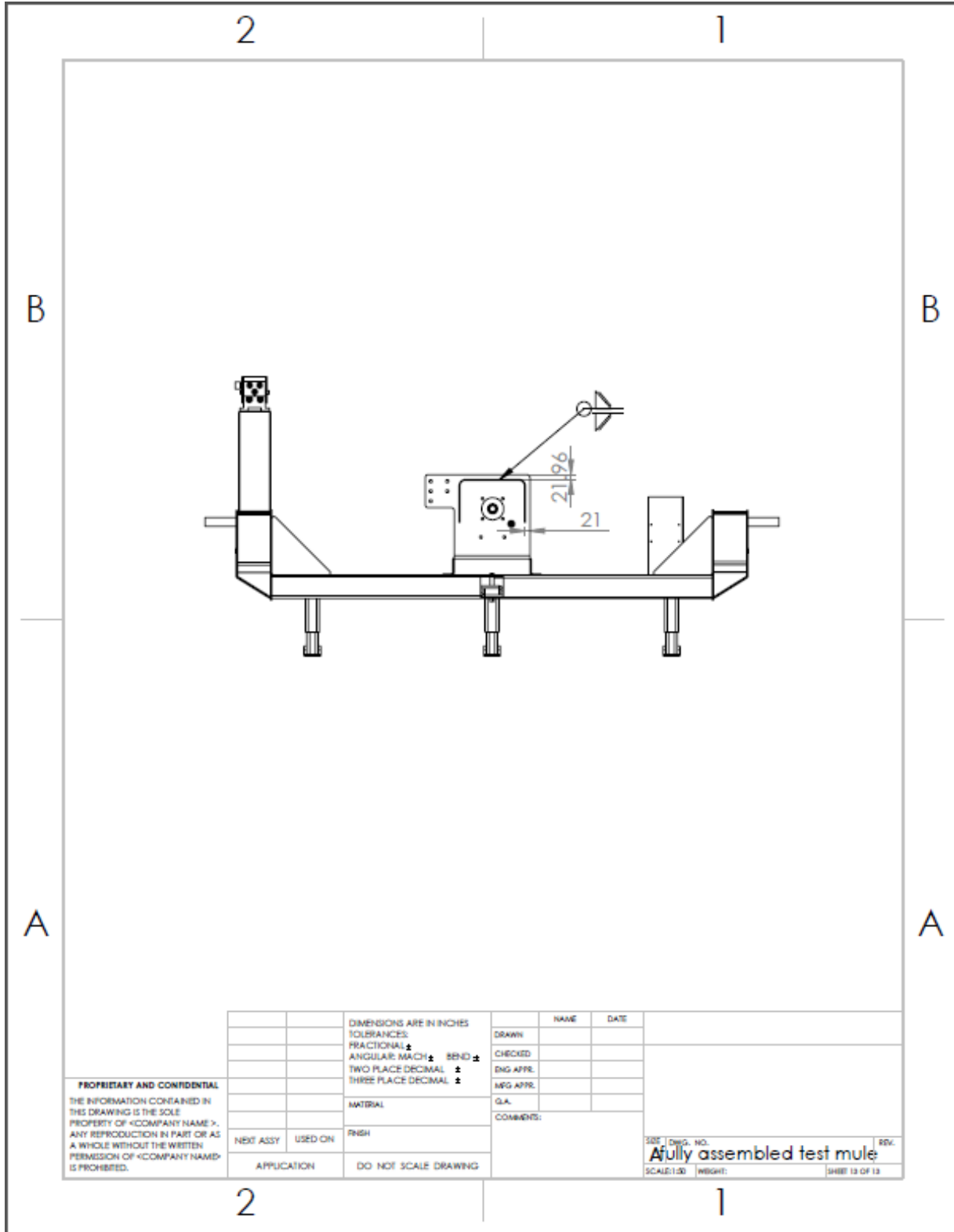



Missing Link Engineering

**Develop & Build a Swather
Implement Mounting Attachment**

MacDon[®]

**Spring Report
4/28/2016**

The Team



Adam

Seth

Carson

Andrew

1. MacDon Background
2. Project Definition
3. Research and Development
4. Hydraulic Systems
5. Structure
6. Testing
7. Recommendations
8. Budget
9. Acknowledgements

Missing Link Engineering

MacDon Industries Ltd.

MacDon®

- Winnipeg, MB
- OEM Company
 - Windrowers
 - Combine Headers



All pictures provided by MacDon Industries Ltd.



MacDon Industries Ltd.

Global Presence

Industry
Preferred

Compatible
with other
major OEMs



- Small farmers need multifunctional equipment
- Windrowers have one very specific purpose
- Tractors and windrowers are expensive
- MacDon's Dual Direction windrowers provide an opportunity for multipurpose equipment



The goal of this project is to create an economical and reliable attachment to allow a MacDon M155 Self-Propelled windrower to pull various non-tillage implements.



- Easily attach to windrower
- Hydraulically driven 540 or 1000 RPM PTO
- Multiple Pioneer quick couplers
- Pull non-tillage equipment only





- Manufacturing cost of \$3500 and MSRP \$5000
- Utilize MacDon's current parts catalog
- Design structural components metric
- Static factor of safety of 1.5-2
- Dynamic factor of safety of 3-4





- Use existing hydraulic power
- Do not modify the existing drive-train or add additional pumps
- Meet ASABE/ISO/OSHA standards
- Mass should not exceed 1700 kg



http://www.rustsales.com/wp-content/uploads/catablog/originals/IMG_4331.JPG



http://www.ssbtractor.com/hay_rakes.jpg

- Patents and competition
- ASABE and industry standards
- Equipment requirements

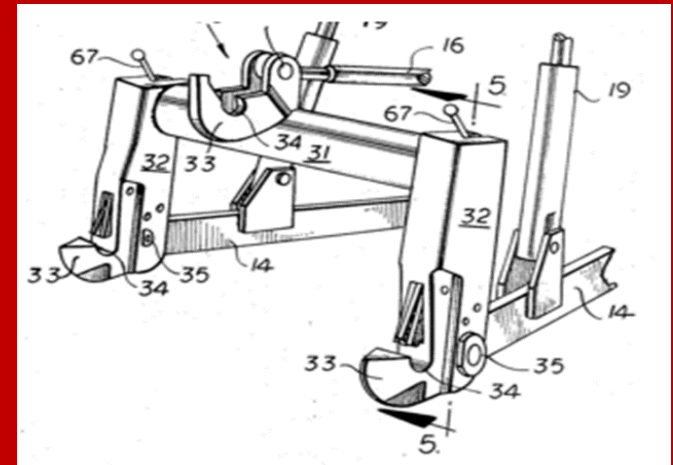

U.S. Patent 3531140A



www.deere.com



www.redpowermagazine.com

Most applicable implement

- 38 balers compiled across 4 brands
- Balers larger than 100 HP omitted
- Target: 70HP

| Baler Analysis | |
|-------------------------|-------|
| Number of brands | 4 |
| Number of balers | 38 |
| Most common HP | 70 |
| Average HP | 61 |
| 540 PTO option | 34 |
| 1000 PTO option | 15 |
| Max Drawbar Weight (N)* | 7829 |
| Max Drawbar Draft (N)** | 14354 |

*Massey Ferguson 2946/2946A

**Vermeer 604 Super M

- Based on PTO HP
- From ANSI/ASABE AD6489-3
- Target HP places windrower in Category 2

| Drawbar Category | PTO power at rated engine (HP) |
|------------------|--------------------------------|
| 0 | ≤ 37 |
| 1 | ≤ 64 |
| 2 | ≤ 154 |
| 3 | ≤ 248 |
| 4 | ≤ 402 |
| 5 | ≤ 671 |

- Assumed to pull in low range (0-11 MPH)
- Inputs taken directly from M155 Tech Manual
- Power reasonable for Category 2

| Power to Wheels Calculations | | | | | | |
|------------------------------|---------|---------|-----------|-----------|-------------|--------|
| V_m (in ³ /rev) | Q (gpm) | P (psi) | T (lb*in) | T (lb*ft) | n_m (rpm) | P (HP) |
| 4.15 | 40 | 5500 | 3633 | 303 | 2227 | 128 |

$$T = \frac{\Delta P * V_m}{2\pi}$$

$$n_m = \frac{Q}{V_m}$$

$$P = \frac{T * n_m}{5252}$$

- ANSI/ASABE Standards Used
- AD6489-3 for drawbar category and design
- AD6489-4 for drawbar category and design

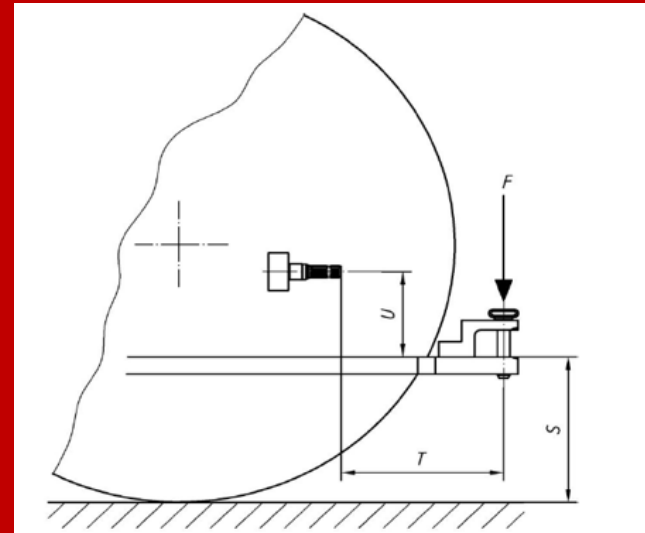
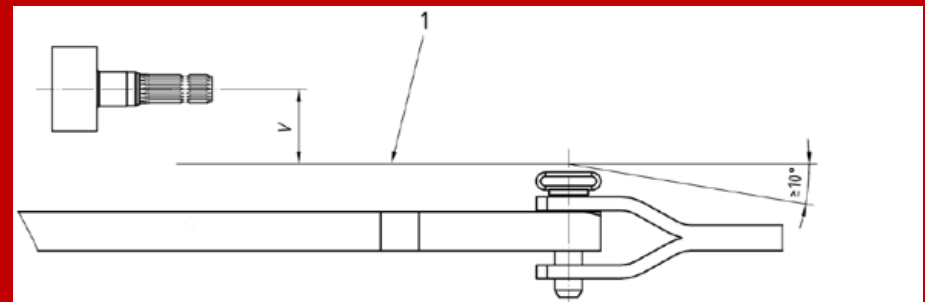

Figure 8-Representation of Table 4 from ANSI/ASABE AD6489-4:2004



a) clevis removed from the drawbar

Figure 11-Representation of Table 7 from ANSI/ASABE AD6489-4:2004

- Use existing hydraulic circuits and compatible hardware
- Five pioneer outlets
- Easy hookup for operator
- Minimize pinch points for safety



From M155 Tech Manual



| Header Type | PIN Code | Max flow (gpm) | Load stall (psi) @ 0 gpm |
|---------------------------|-------------|----------------|--------------------------|
| R80/R85 Disc on M155 | 0001 | 27-30 | 4000-4200 |
| A40-D Auger | 0011 | 26.5-29.5 | 4000-4200 |
| A30-D Auger | 0110 | 26-28 | 4000-4200 |
| A30-S Auger | 0010 | 22-23 | 4000-4200 |
| GSS Auger | 1010 | 26.5-29.5 | 4000-4200 |
| D-Series Draper DK | 0100 | 26.5-29 | 4000-4200 |
| D-Series Draper DK | 1111 | 21-24 | 4000-4200 |
| D-Series Draper DK | 0111 | 19.5-23 | 4000-4200 |
| D-Series Draper DK | 1101 | 18-21 | 4000-4200 |
| D-Series Draper DK | 1100 | 18-21 | 4000-4200 |
| D-Series Draper SK | 1101 | 14.5-17.5 | 4000-4200 |
| D-Series Draper SK | 0101 | 18-21 | 4000-4200 |
| D-Series Draper SK | 1001 | 18-21 | 4000-4200 |
| D-Series Draper SK | 1000 | 17-20 | 4000-4200 |
| D-Series Draper Dk | 1001 | 18-21 | 4000-4200 |

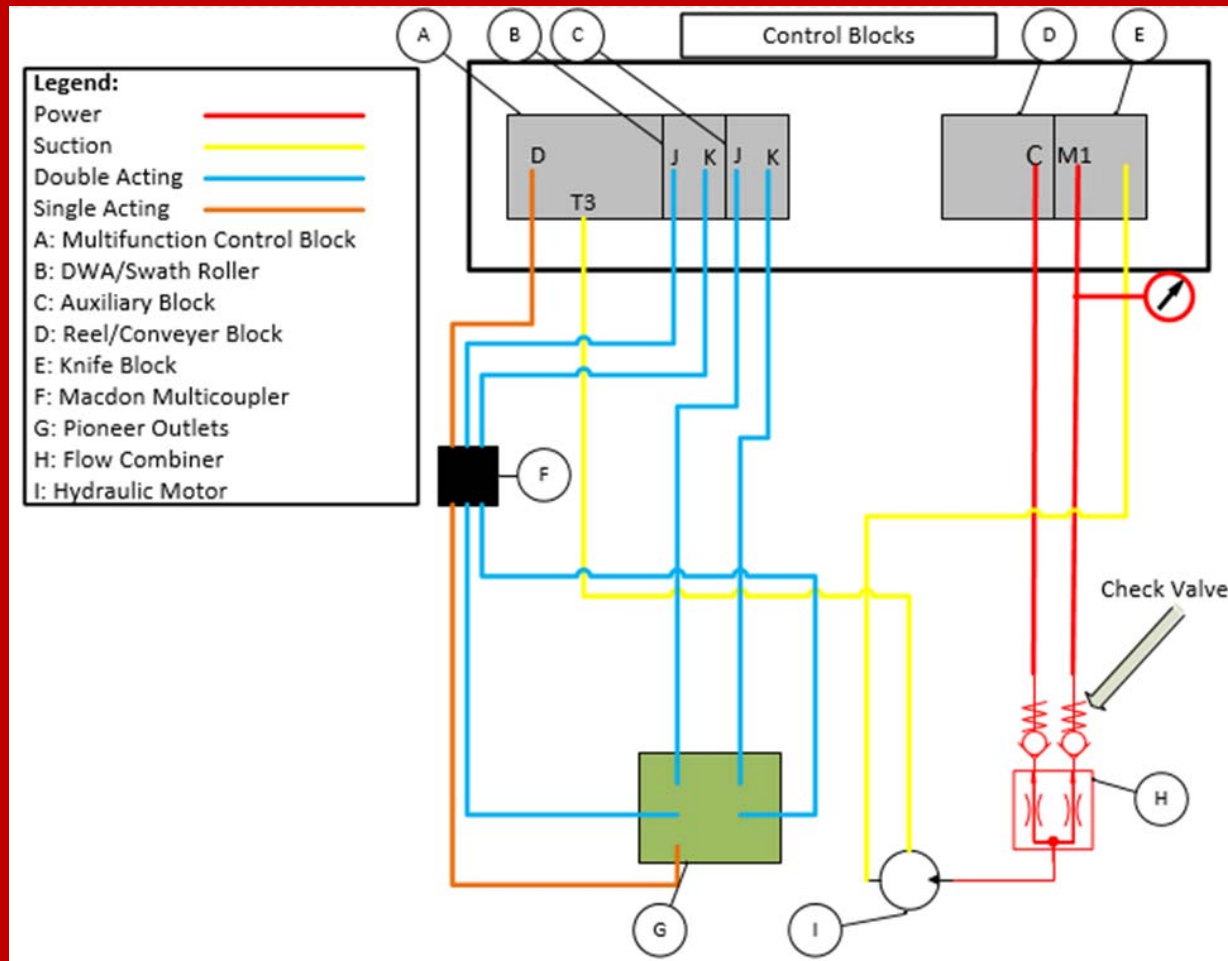



- D-series has multiple header drive functions
- Draper Pressure changed to 4000 psi
- Meets criteria for 70HP

| Drive Hydraulic Power | | | |
|-----------------------|----------------|--------------------|-----------|
| Pump | Flowrate (gpm) | Pressure (psi) | HP |
| Knife | 27 | 4000 | 63 |
| Draper | 15 | 4000 | 35 |
| | | Theoretical | 98 |

$$HP = \frac{Q * P}{1714}$$

- Used on R85 Pull-Type Disc Mower
- Parker Hannifin F12 Series 80cc/rev
- High efficiency over a wide range of speeds

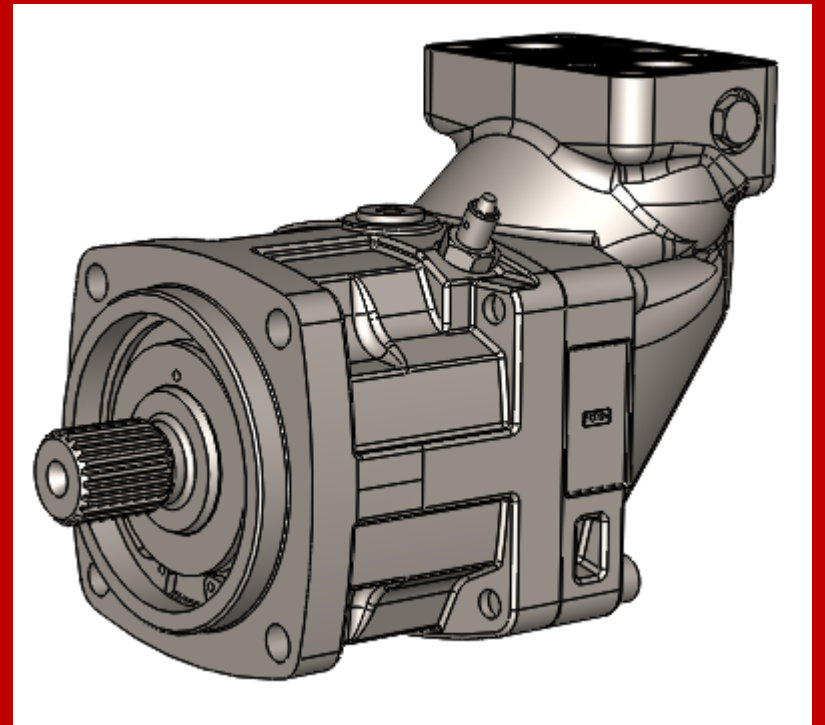

- Used on R85 Pull-Type Disc Mower
- Comer A-640A
- 540 PTO shaft
- Gear ratio of 1:2-3.8





- Gearbox allows for design torque with smaller displacement motor
- Current gearbox has 2:1 reduction
- Change of gear ratio to 3:1 increases power to 80HP

Maximum Horsepower using gearbox and motor from R85 pull type

| Variable | Value | Unit |
|--------------|-------------|-----------|
| Displacement | 80 | cc/rev |
| Pressure | 4000 | psi |
| Speed | 540 | rpm |
| Gear Ratio | 2:1 | |
| Flowrate | 22.8 | gpm |
| Power | 53.3 | HP |

- Combines multiple circuits at lower cost than outsourcing
- Made from 6061-T6 Aluminum
- FEA performed with 4000 psi static

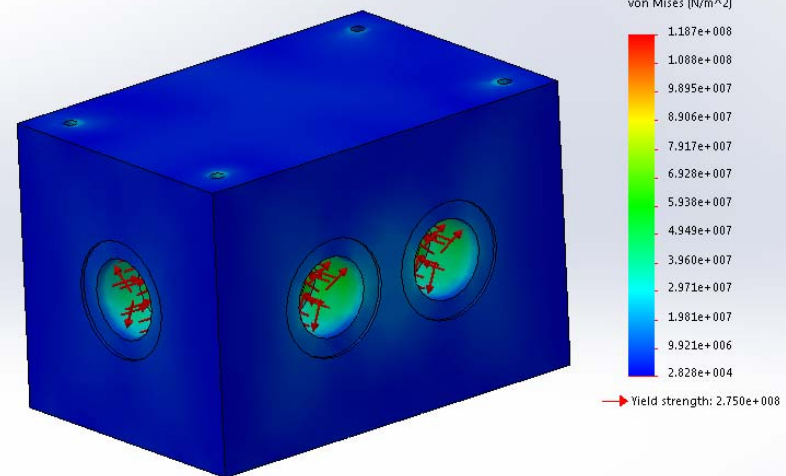
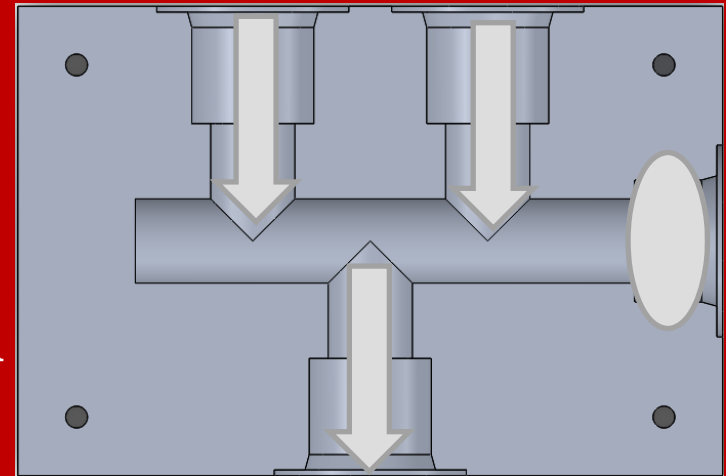

$$\sigma_t = \frac{r_i^2 p_i}{r_o^2 - r_i^2} \left(1 + \frac{r_o^2}{r^2} \right)$$

- 5 connections to Pioneer quick couplers
- Reel functions used for one single acting and one dual acting
- DWA (Double Windrow Attachment) circuit used for second dual acting circuit

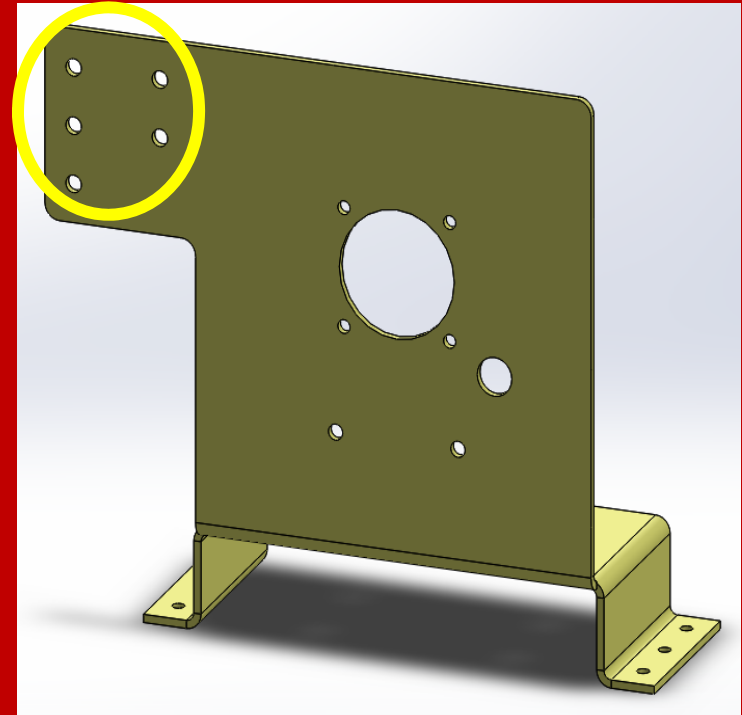

Connections for outlets

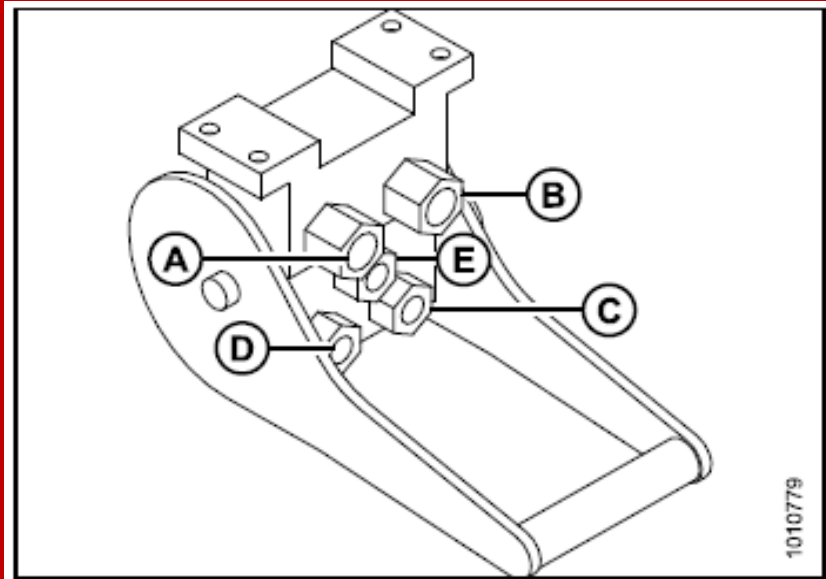
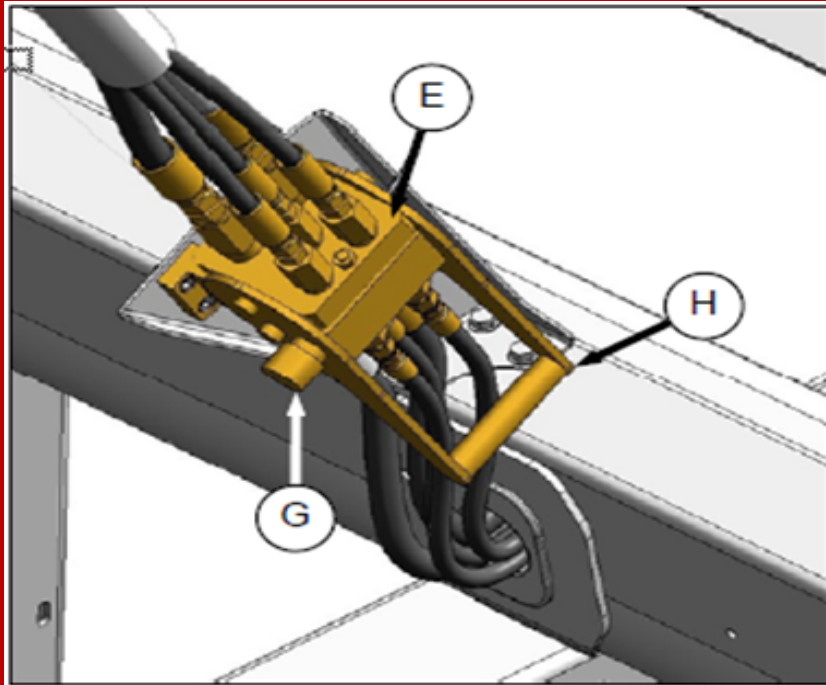
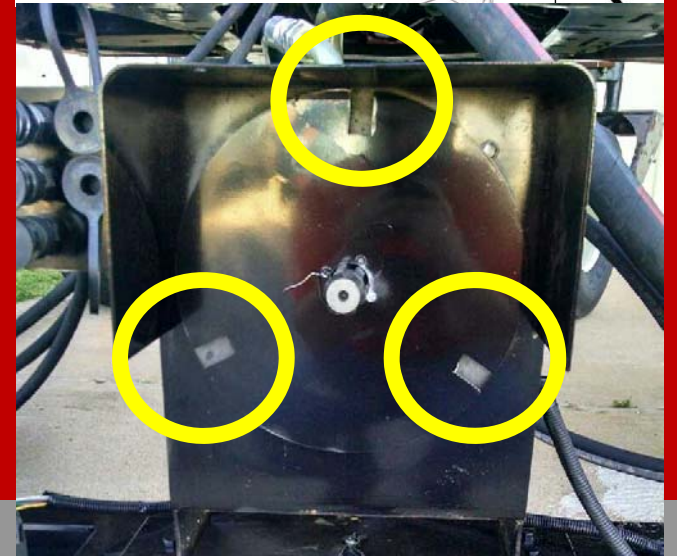
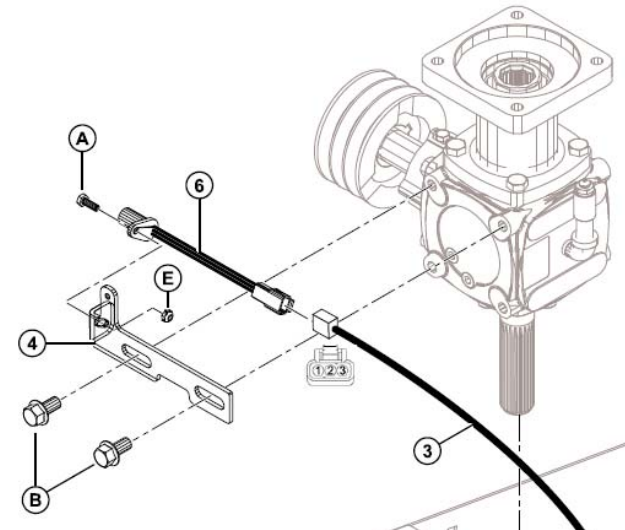
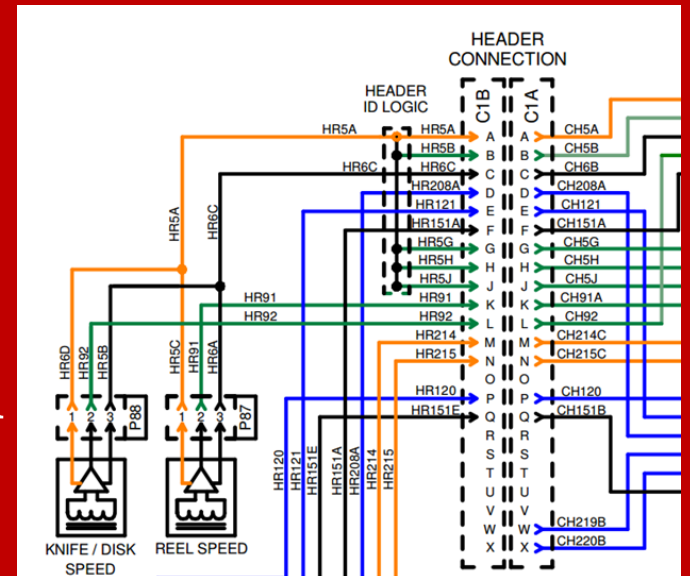
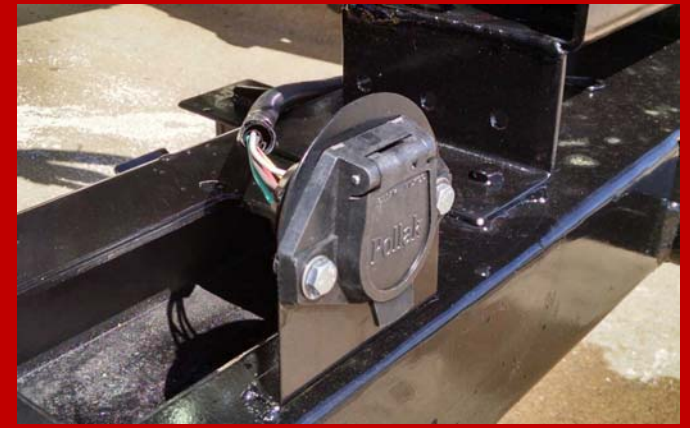

Figure 6.25: Header Multicoupler (Back View)
(MD #153151)

- RPM shown on CDM
- Hall effect sensor
- Speed sensor mounted to gearbox mount
- Reads from plate mounted to PTO



- Wiring harness from weight box
- Wired to force the header ID code
- Integrates speed sensor
- Allows for all lights to be operated on towed equipment



The Mule

Design:

- Three-point connection
- Swinging drawbar
- High factor of safety

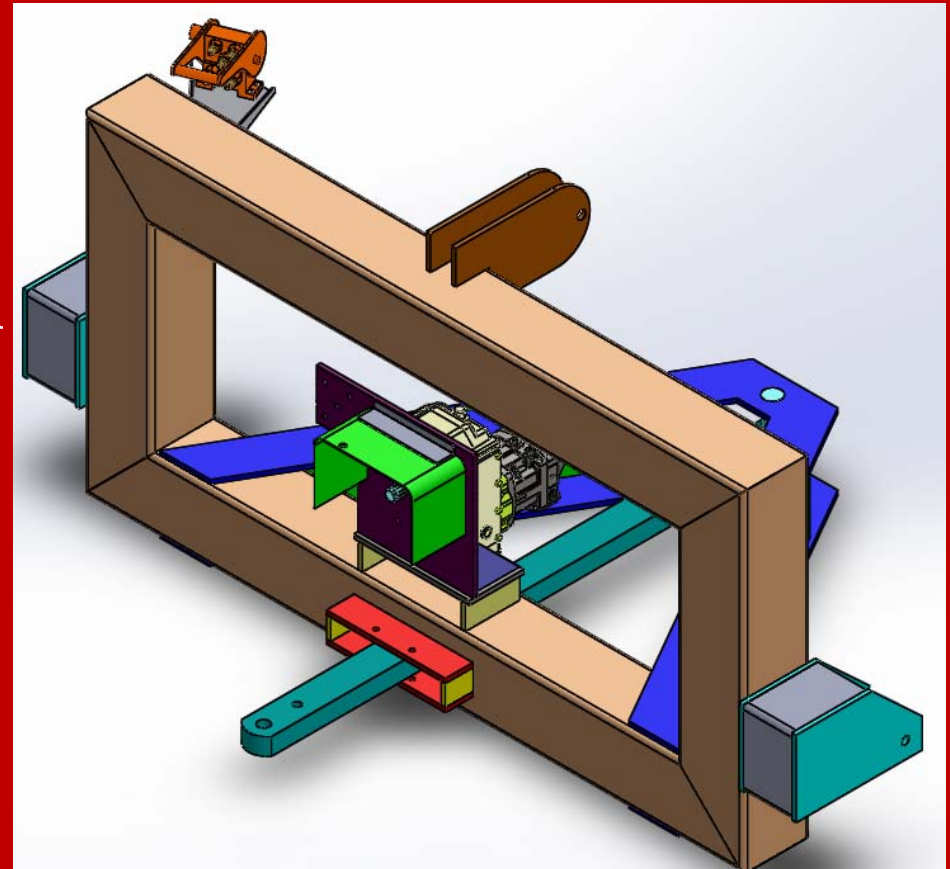

- Two point connection
- Simplified structure
- Lower material costs
- Less debris collection
- Same hydraulic system

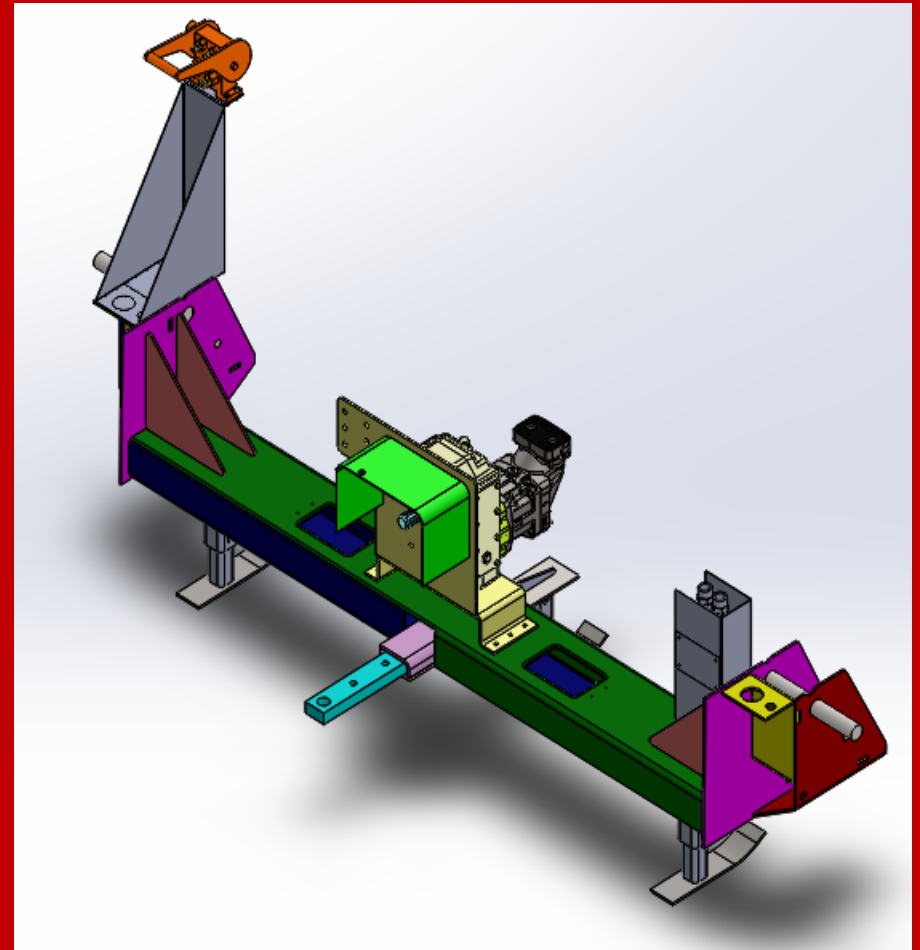



- Two pieces that are structurally the same
- 1/4" inch steel plate
- Top plate has mounting and access holes

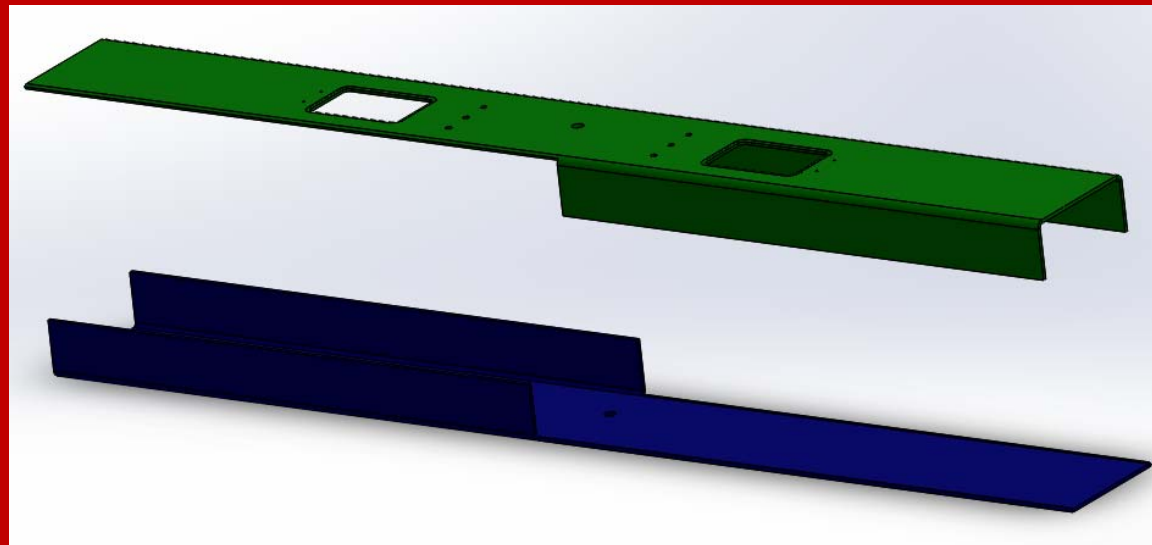

- Lower lift arms used for mounting
- Uses same mounting hardware as a MacDon weight box
- Similar mounting orientation as other MacDon headers

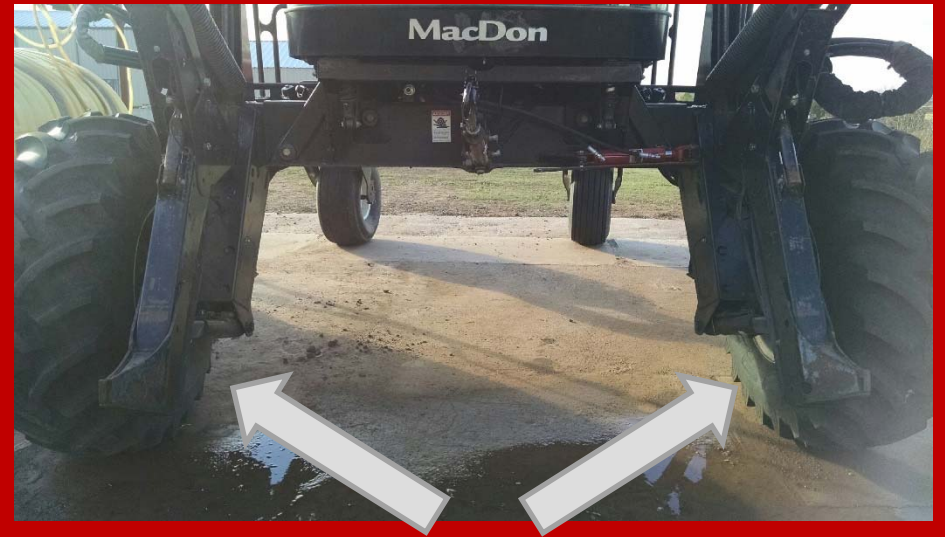

- Bottom boots fit directly over windrower legs
- Uses mounting boots from MacDon weight box
- Lower material cost than fall design

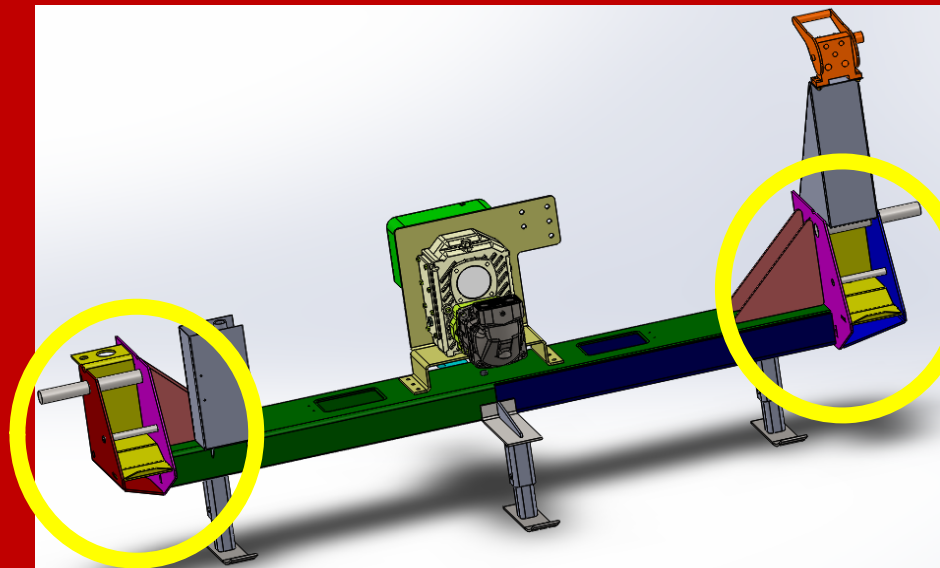

- Sourced class 2 drawbar
- 3/8" metal plate housing
- Pinned under PTO

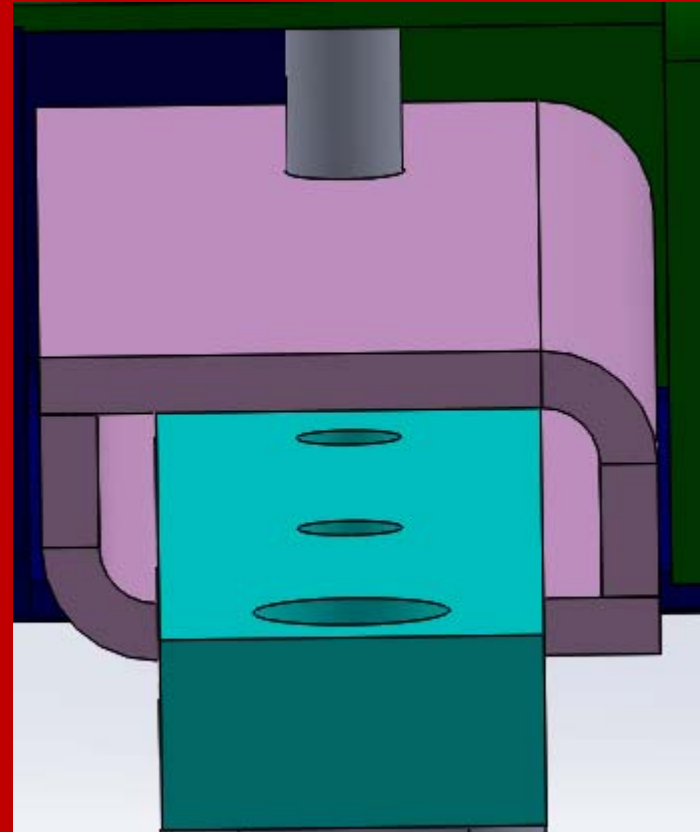

- Fabricated from single plate of steel
- Allows for post assembly mounting of gearbox
- Auxiliary outlet mounting holes

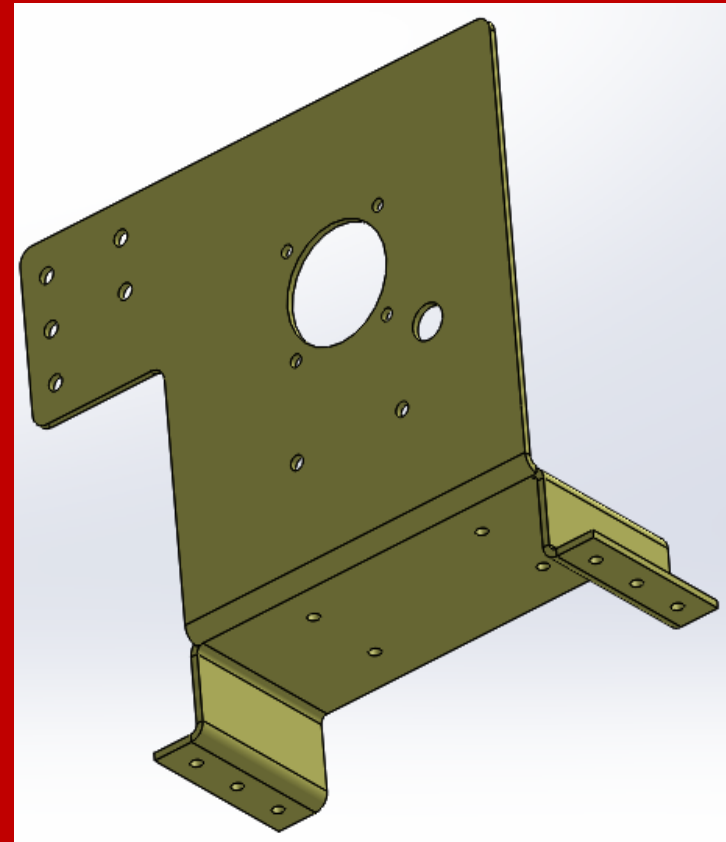

- Allows access to gearbox mount bolts
- Hinged covers can be added to prevent debris buildup
- Allows for addition of ballast

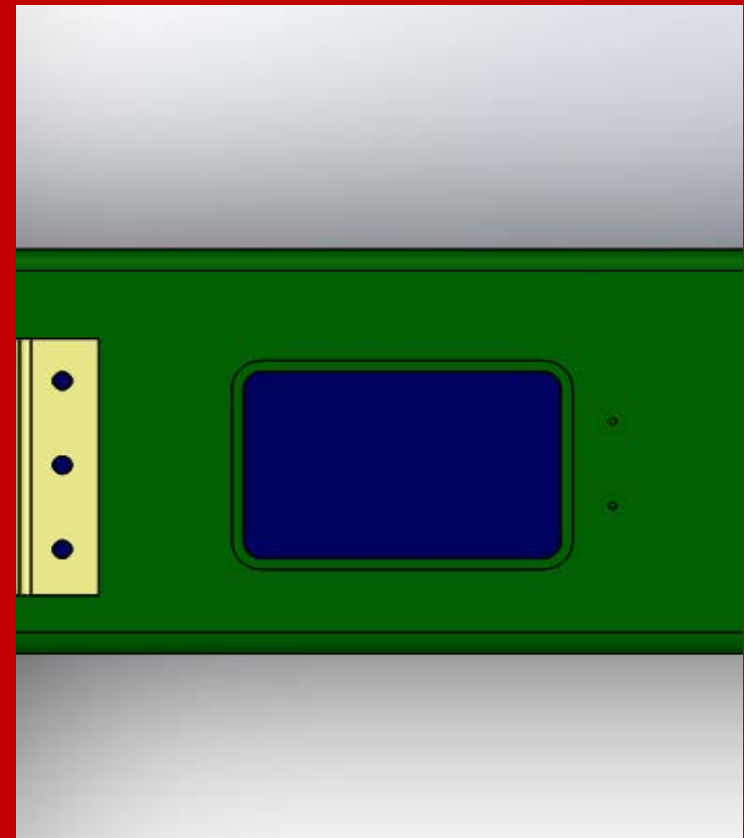

- Prevents ground contact
- Lift after connected
- Curved feet design

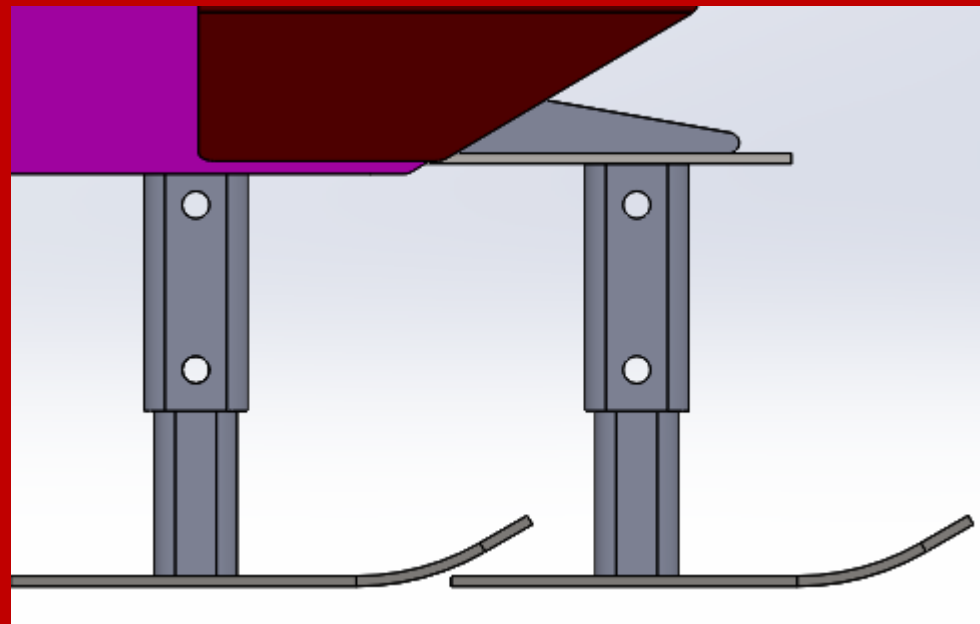

- Single sheet fabrication
- Sits on top of boot mount
- Mounts hydraulic multicoupler

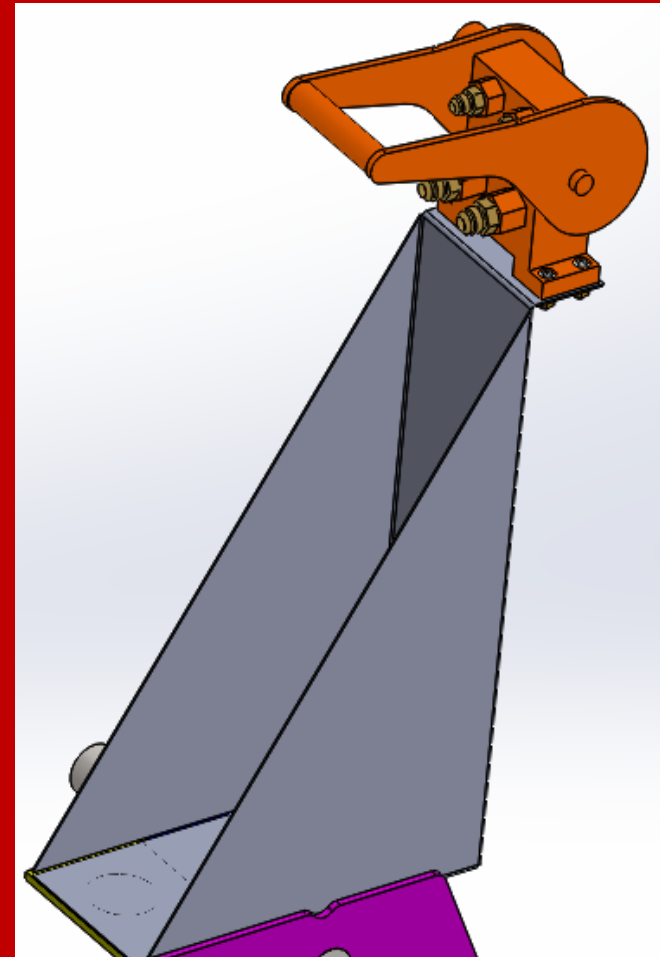

- Single sheet fabrication
- Hydraulic manifold bolts in to center of mount
- Shields manifold and attached fittings

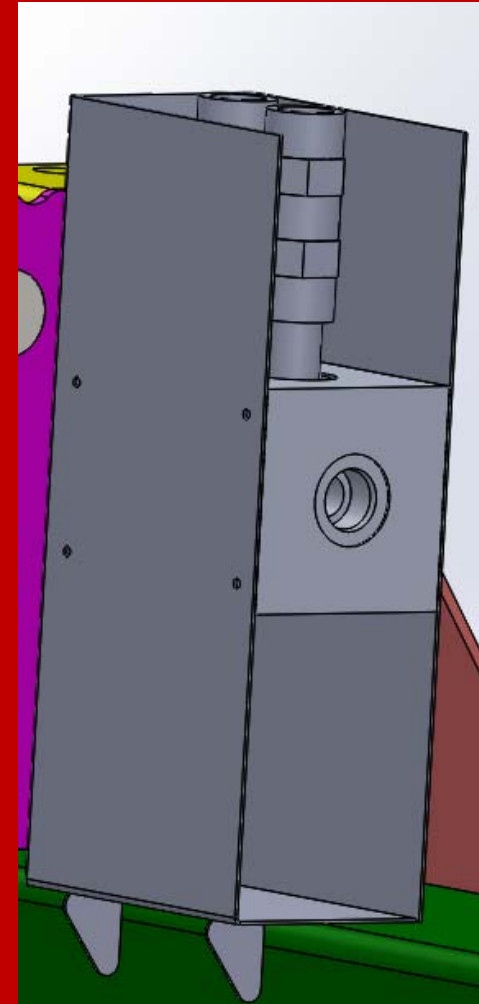

- 15,000 N draft force
- 542 N-m torque
- Static FOS: 2.08
- Dynamic FOS: 3.30

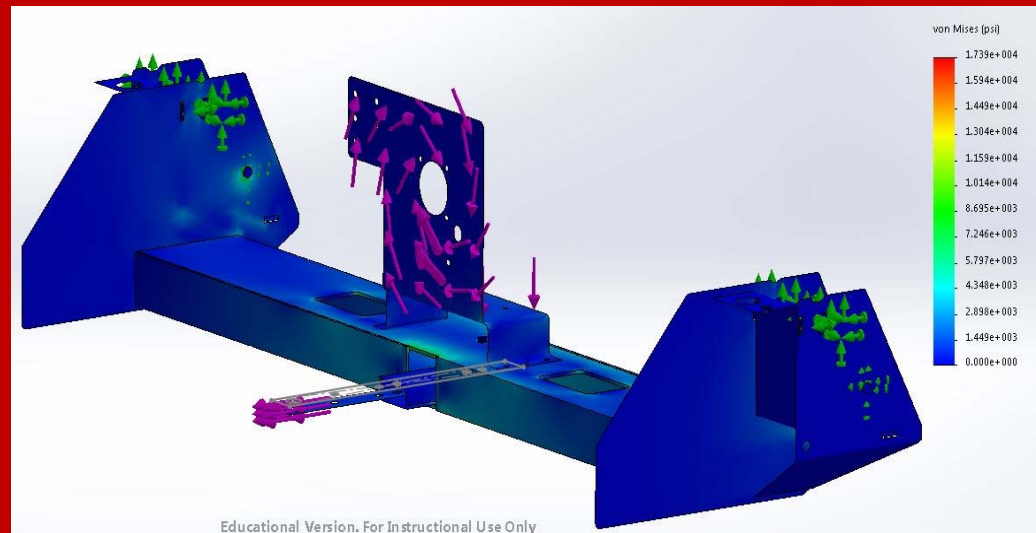

- Same forces applied as in stress analysis test
- Minimal displacement
- Most occurred in the center, on drawbar and PTO mount

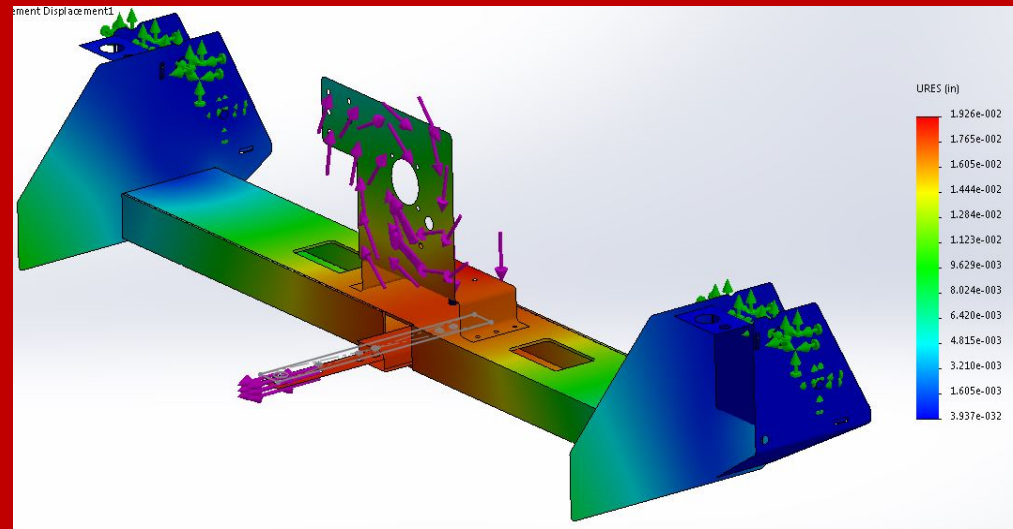

- PTO Shield
- Addition of a rock shield
- Signs and Warnings

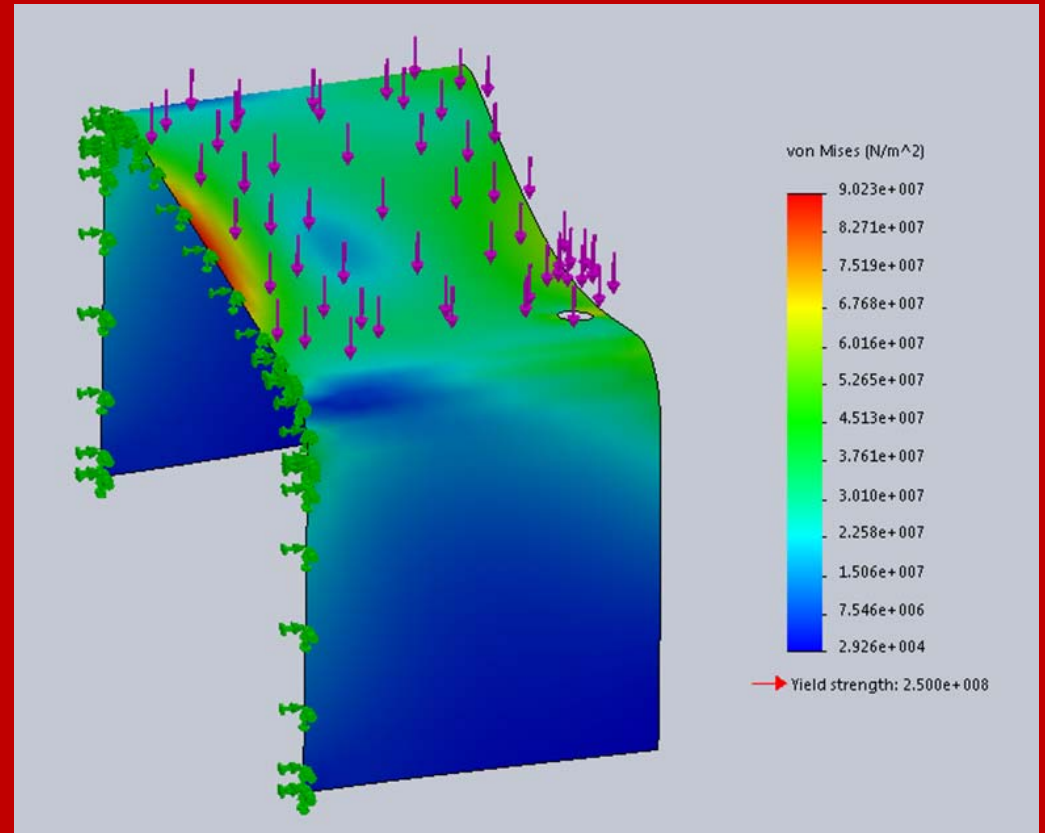



- Operate in position of a weight box
- Have to adjust up pressure of draper circuit
- Install hoses from DWA block to in front of cab
- Set header controls in CDM menu
- Connect hydraulics and electrics



The Mule 2.0





- PTO Dynamometer
(Courtesy of Dr. Ajay Kumar)
- Output of Torque, Speed, and Power



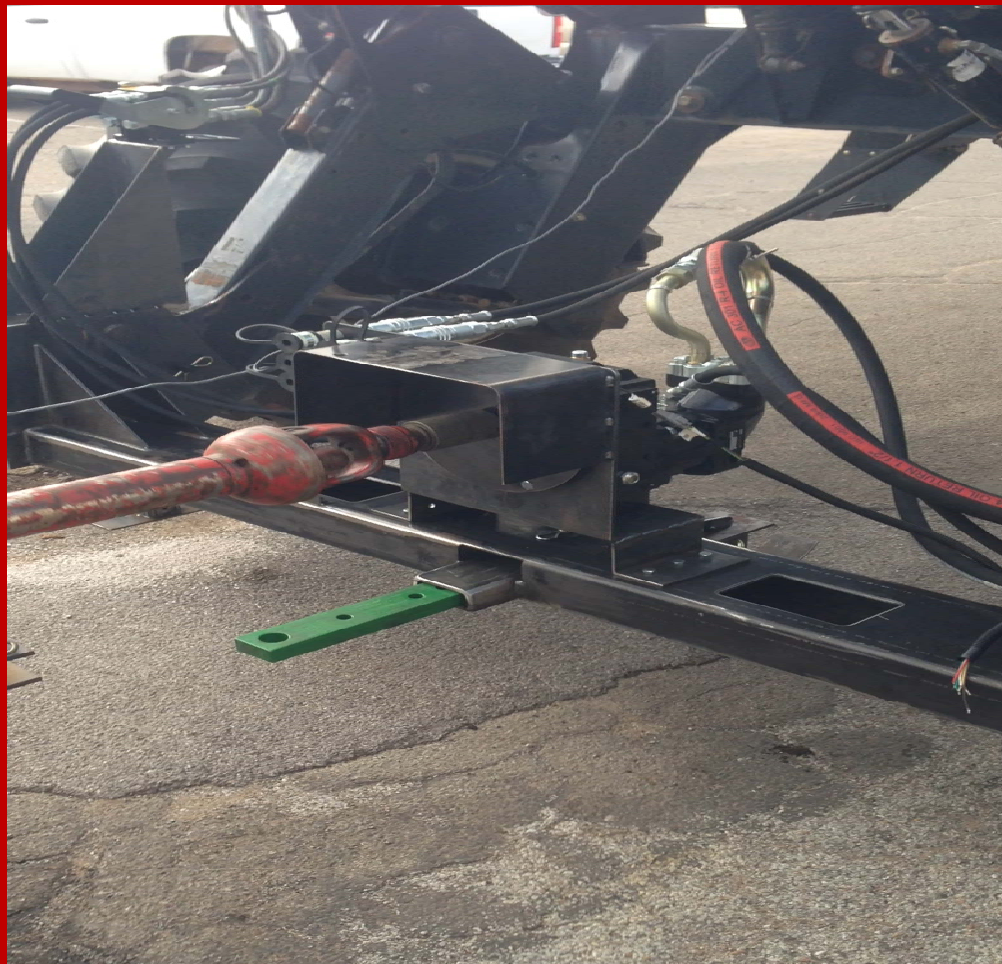



15ft Draper Header Setup

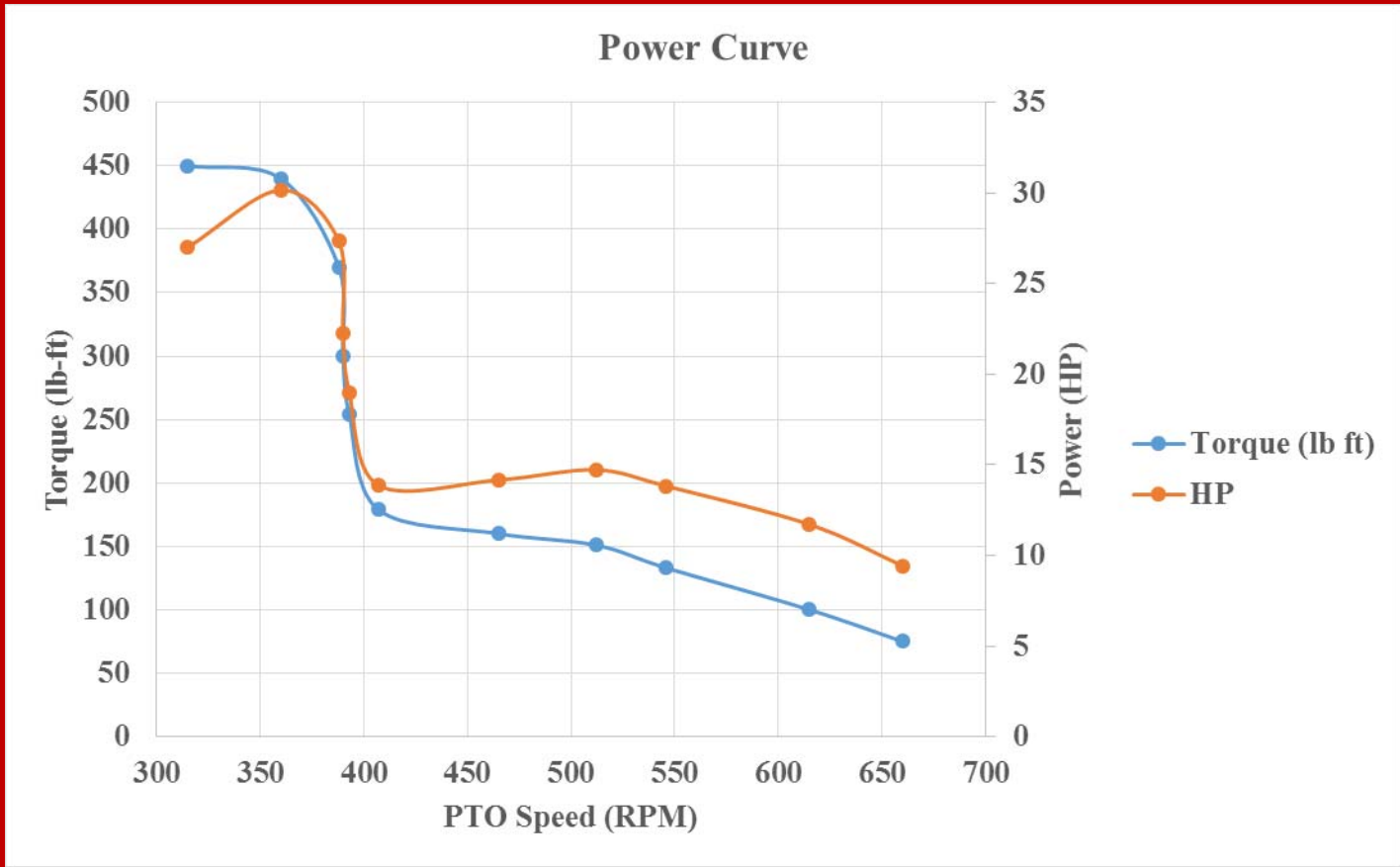

- Pressure Gage to Verify Knife Load
- Diagnostic Mode
 - Activate Functions: Test Knife Circuit



| Drive Hydraulic Power | | | |
|-----------------------|----------------|----------------|----|
| Pump | Flowrate (gpm) | Pressure (psi) | HP |
| Knife | 29 | 4000 | 68 |



Power Curve Scaled to 3:1 Reduction

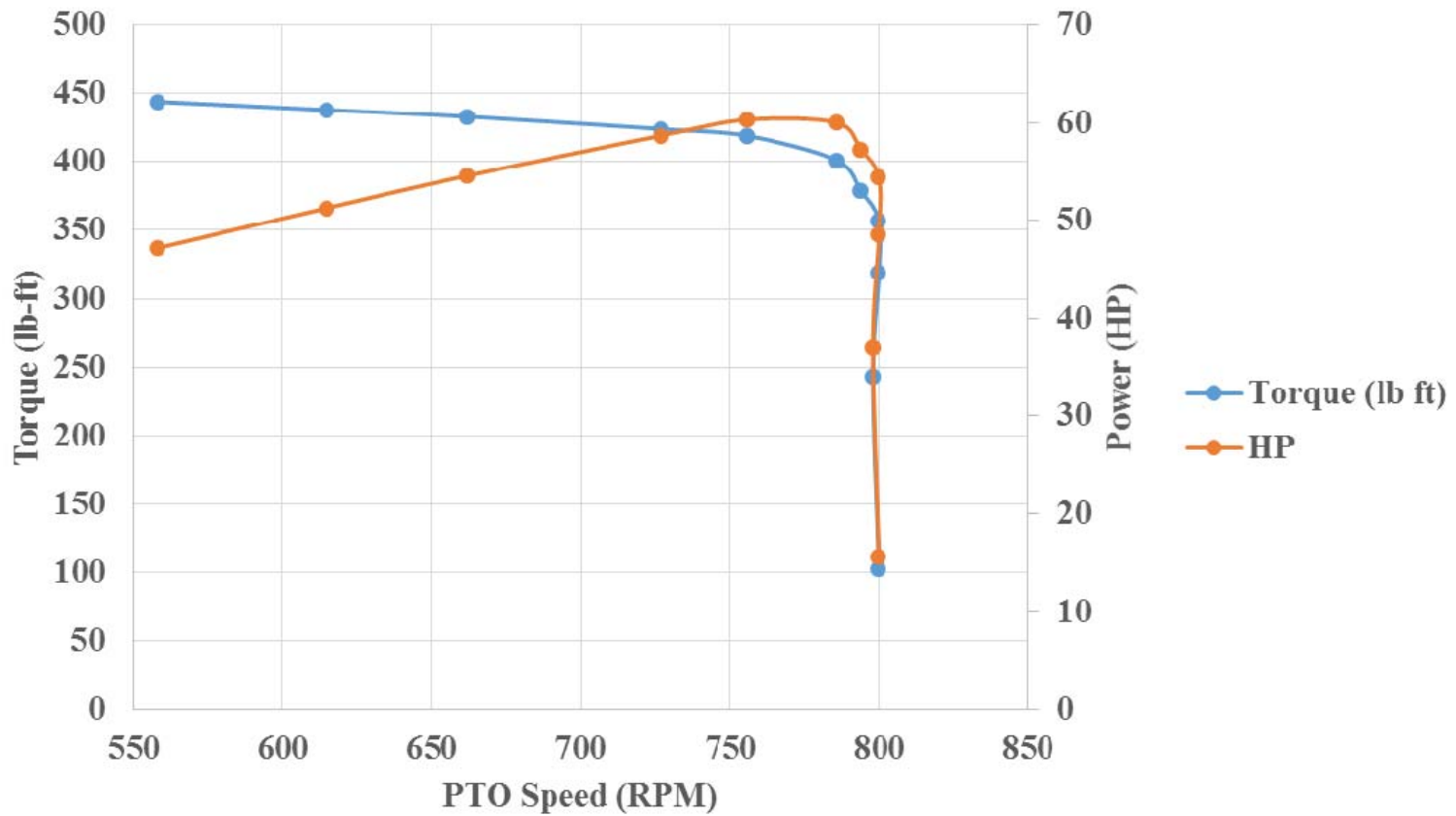



- **Verify Flowrates and Pressure from Draper Circuit**
 - Could not achieve expected power
- **Speed Sensor Pickup on CDM**
 - Distance set
 - Voltages verified
- **Verify Flow Characteristics from Auxiliary Outlets**
 - All outlets functioned
 - Pressure and Flow should be tested to verify operating conditions

Design Moving Forward:

- 3:1 Reduction Gearbox
- Automatic Pressure Adjustments
- Single Point Drive Connections
- Use Metal Lines
- Reposition Skids



Operation section included in operator's manual

Safety Switch:

Lockouts needed:

- Lift
- Tilt
- Header Reverse

Allows:

- Header engagement in engine forward



| Component | Source | Qty | Cost |
|-----------------------------------|--------------------------|--------|------------|
| Frame and Drawbar | | | |
| 1/16" Plate | Stillwater Steel | 2'x4' | \$21.60 |
| 1/4" Plate | Stillwater Steel | 4'x16' | \$399.36 |
| 3/8" Plate | Stillwater Steel | 1'x1' | \$26.08 |
| Square Tubing | Stillwater Steel | 3' | \$30.88 |
| Drawbar | John Deere | 1 | \$304.50 |
| 2" Drawbar pin (1' stock) A36 | Stillwater Steel | 1 | \$20.00 |
| PTO Shield (11 gauge 1'x4' sheet) | onlinemetals.com | 1 | \$25.00 |
| PTO | | | |
| Gearbox | MacDon (Comer) | 1 | \$684.00 |
| Hydraulic Motor | MacDon (Parker-Hannifin) | 1 | \$1,437.00 |
| Hydraulic Manifold | onlinemetals.com | 1 | \$80.00 |
| Hoses and Fittings | NAPA | 5 | \$600.00 |
| Check Valves | Stucchi | 2 | \$60.00 |
| Flat Face Connectors | MacDon | 4 | \$200.00 |
| Speed Sensor | MacDon | 1 | \$70.00 |
| Wiring Harnesses | MacDon | 1 | \$60.00 |



Auxiliary Hydraulics

| | | | |
|--------------------------|----------------------|---|----------|
| Hydraulic Receiver Block | MacDon | 1 | \$980.00 |
| Pioneer outlets | McMaster-Carr | 5 | \$100.00 |
| Dust Covers | McMaster-Carr | 5 | \$20.00 |
| Flat Face Connectors | Livingston Machinery | 4 | \$200.00 |
| Hoses and Fittings | NAPA | 5 | \$220.00 |

Shop/Manufacturing

| | | | |
|--|-----------------|--------|----------|
| Cutting/Welding/Assembly/Etc (\$20/hr) | Biosystems Shop | 20 hrs | \$400.00 |
|--|-----------------|--------|----------|

Misc. Hardware

| | | | |
|-----------------|-----------------|----|---------|
| Nuts/Bolts/Pins | Biosystems Shop | 23 | \$20.00 |
|-----------------|-----------------|----|---------|

| | |
|--------------|-------------------|
| Total | \$5,933.42 |
|--------------|-------------------|

- Dr. Paul Weckler
- Dr. John Long
- Dr. Ajay Kumar
- Mr. Donny Putro
- Mr. Jeffrey Leachman
- The Biosystems Lab Staff
- Mr. Collin Craige
- Varitrac Engineering
- BAE 1012 Freshman Teams
- Katie from NAPA

- Dunn, J.T., et al. 2007. Tractor with reversible operator position for operation and transport, U.S. Patent No. 7159687B2
- Fadden, D. K., and Fosco, L.D. 1970. Tractor quick hitch attachment, U.S. Patent No. 3531140A
- Honey, G. J. 1991. Swather attachment for bi-directional tractor, U.S. Patent No. 5031394A
- Degelman, W. J. 2000. Multi-functional self-propelled farm tractor, U.S. Patent No. 6160643B1
- Paumier, J. 2002, Vertical underground stump grinding apparatus, U.S. Patent No. 20040098885A1
- ANSI/ASABE Standard AD6489-3:2004, July 2004, "Agricultural vehicles-Mechanical connections between towed and towing vehicles-Part 3: Tractor drawbar," www.asabe.org
- ANSI/ASABE Standard AD11384:1995 (April 2011), May 2011, "Tractors, machinery for agricultural and forestry, powered lawn and garden equipment – Safety signs and hazard pictorials – General principles," www.asabe.org
- ASABE/ISO 500-1:2014, Feb 2015, "Agricultural tractors – Rear-mounted power take-off types 1, 2, 3 and 4 - Part 1: General specifications, safety requirements, dimensions for master shield and clearance zone," www.asabe.org
- ASABE/ISO 500-3:2014, Feb 2015, "Agricultural tractors – Rear-mounted power take-off types 1, 2, 3, and 4 - Part 3: Main PTO dimensions and spline dimensions, location of PTO," www.asabe.org
- ANSI/ASAE S366.2, May 2004, "Agricultural tractors and machinery – General purpose quick-action hydraulic couples," ISO 5675:1992, www.asabe.org
- Occupational Safety & Health Administration [OSHA]. 1976. Regulations (Standard – 29 CFR).1928. Retrieved from http://www.osha.gov/pls/oshaweb/owadisp.show_document?p_table=STANDARDS&p_id=10958
- "Farm Injury Resource Center." *Farm Injury Resource Center*. N.p., n.d. Web. 29 Nov. 2015.
- MacDon. (2012). *M155 Self-Propelled Windrower: Operator's Manual*. Winnepeg, CA
- MacDon. (2012). *D65 Harvest Header For Self-Propelled Windrowers: Operator's Manual*. Winnepeg, CA
- Budynas, R. G., Nisbett, J. K., (2015). *Shigley's Mechanical Engineering Design* (10th ed.). New York, NY: McGraw-Hill Education
- Sriastava, A. K., et al., (2012). *Engineering Principles of Agricultural Machines* (2nd ed.). ASABE
- engineeringtoolbox.com
- tractorhouse.com



FALL 2015 REPORT

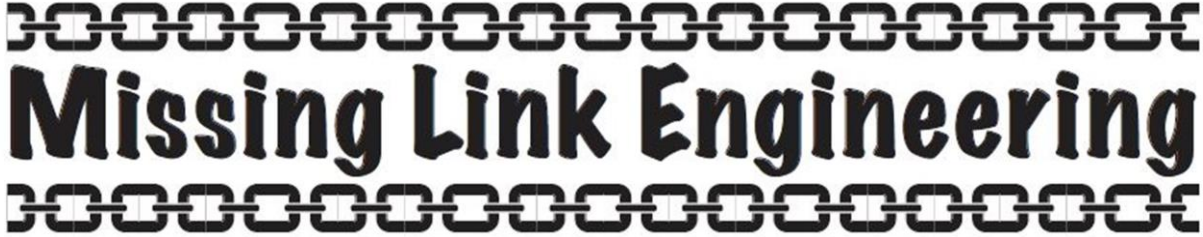

Missing Link Engineering

MacDon Industries, Ltd.

Adam McKay

Carson Brian

Seth Cleary

Andrew Farrand

OKLAHOMA STATE UNIVERSITY

Contents

| | |
|--------------------------------|----|
| Table of Contents..... | 1 |
| List of Figures..... | 2 |
| List of Tables..... | 3 |
| Mission Statement..... | 5 |
| Introduction..... | 6 |
| Customer Requirements..... | 9 |
| Technical Requirements..... | 11 |
| Product Research..... | 22 |
| Project Impact..... | 25 |
| Design Concepts..... | 26 |
| Recommendation..... | 51 |
| Proposed Prototype Budget..... | 52 |
| Project Schedule..... | 53 |
| References..... | 54 |

List of Figures

| | |
|---|-----------|
| Figure 1-MacDon M155 Self-Propelled Windrower from M155 operator’s manual..... | 5 |
| Figure 2-A display of countries with a strong MacDon presence from MacDon’s website ... | 6 |
| Figure 3-MacDon's Dual Direction® system allows the windrower to be driven engine forward from M155 operator’s manual..... | 7 |
| Figure 4-Illustration of changing direction of travel in the windrower from MacDon website..... | 8 |
| Figure 5-Windrower with weight box pulling a header from M155 owner’s manual..... | 9 |
| Figure 6-Button layout of hydro joystick from M155 owner’s manual..... | 10 |
| Figure 7-Representation of Table 2 from ANSI/ASABE AD6489-4:2004..... | 13 |
| Figure 8-Representation of Table 4 from ANSI/ASABE AD6489-4:2004..... | 14 |
| Figure 9-Location of Pin hole relative to rear tires from ANSI/ASABE AD6489-4:2004.... | 15 |
| Figure 10-Drawbar Specifications Based on Table 6 from ANSI/ASABE AD6489-4:2004. | 16 |
| Figure 11-Representation of Table 8 from ANSI/ASABE AD6489-4:2004..... | 17 |
| Figure 12-Distance of PTO Box Relative to Bottom of Rear Tires from ASABE/ISO 500-3:2014 | 18 |
| Figure 13-PTO Shield Schematic from ASABE/ISO 500-1:2014..... | 19 |
| Figure 14-Figure for dimensions of hydraulic outlet from ANSI/ASAE S366.2 MAY2004 | 20 |
| Figure 15-A quick hitch detailed in U.S. Patent 3531140A..... | 22 |
| Figure 16-Application of U.S. Patent 5031394A | 23 |
| Figure 17-Application of U.S. Patent 6460643B1..... | 24 |
| Figure 18-Application of U.S. Patent 20040098885A1 | 24 |
| Figure 19-Header Engage/Disengage Switch from M155 operator’s manual..... | 26 |
| Figure 20-Auxiliary hydraulic coupling plate from D65 owner’s manual | 27 |
| Figure 21-Auxiliary hydraulics attached to coupling plate from D65 owner’s manual..... | 27 |
| Figure 22-Full time flow hydraulic hookups which will be used for PTO power from D65 owner’s manual..... | 27 |
| Figure 23-Rear view of attachment with hydraulic outlet connections | 28 |
| Figure 24- Pioneer quick coupler from McMaster-Carr | 28 |
| Figure 25-Side view of MacDon weight box from M155’s owner’s manual..... | 29 |
| Figure 26-Rounded frame, plate mounting | 34 |
| Figure 27-Rounded frame, tubing mounting..... | 35 |

| | |
|--|-----------|
| Figure 28-Square frame, plate mounting..... | 36 |
| Figure 29-Parker Hannifin Pump Model | 37 |
| Figure 30-Parker Hannifin Pump Operation Speed..... | 37 |
| Figure 31-Comer A-649A Gearbox | 39 |
| Figure 32-A2FM28 Bosch Pump | 39 |
| Figure 33-PTO gearbox mount..... | 40 |
| Figure 34-Front view of PTO gearbox mount..... | 41 |
| Figure 35-Lower view of PTO gearbox mount..... | 42 |
| Figure 36-Freshmen group 1 transport wheel proposal..... | 43 |
| Figure 37-Freshmen 1 group transport wheels folded | 43 |
| Figure 38-Freshmen group 2 hitch concept in transport configuration | 44 |
| Figure 39-Freshmen group 2 hitch concept mounted for storage | 44 |
| Figure 40-Stabilizer wheel from D65 header operator’s manual..... | 45 |
| Figure 41-Front caster, slow-speed transport wheels from D65 header operator’s manual..... | 45 |
| Figure 42-Hitch connection process from D65 owner's manual..... | 46 |
| Figure 43-Proposed mounting of wheels..... | 46 |
| Figure 44-PTO master shield stress simulation with 1200 N load and 11 gauge A36 steel.. | 49 |
| Figure 45-PTO master shield deflection simulation with 1200 N load and 11 gauge A36 steel | 49 |
| Figure 46-Recommended prototype..... | 51 |
| Figure 47-Project Gantt chart | 53 |

List of Tables

| | |
|---|-----------|
| Table 1-Task List for Project Completion..... | 8 |
| Table 2-Analysis of power requirements for balers..... | 11 |
| Table 3-Calculation of power applied to the ground by the wheels..... | 12 |
| Table 4-Auxiliary hole diameter and distance to pin hole | 13 |
| Table 5-Location of drawbar relative to PTO for regular drawbar position | 14 |
| Table 6-Location of drawbar relative to PTO for short drawbar position | 14 |
| Table 7-Drawbar Specifications Based on Category 2 Drawbar..... | 15 |
| Table 8-Clearance Distance of Pin | 16 |

| | |
|---|-----------|
| Table 9-Distance of PTO Box Relative to Bottom of Tire..... | 17 |
| Table 10- PTO Shield Dimensions..... | 19 |
| Table 11-Weight Maximums on Axles from M155 Owner’s Manual..... | 21 |
| Table 12-Pure bending factor of safety calculations..... | 32 |
| Table 13-Split bending and shear factor of safety calculations..... | 33 |
| Table 14-Split bending and shear factor of safety calculations using flat plate..... | 33 |
| Table 15-Theoretical hydraulic horsepower..... | 38 |
| Table 16-Operation Requirements..... | 38 |
| Table 17-Gearbox Rating..... | 39 |
| Table 18-Bosch Pump..... | 39 |
| Table 19-Table depicting pros and cons and support systems..... | 47 |
| Table 20: Prototype budget breakdown..... | 52 |

List of Equations

| | |
|---|-----------|
| Equation 1-Power calculation..... | 12 |
| Equation 2-Hydraulic motor torque..... | 12 |
| Equation 3-Hydraulic motor rotational velocity..... | 12 |
| Equation 4-Static force equations..... | 29 |
| Equation 5-Force to begin moving a fully loaded implement..... | 30 |
| Equation 6-Endurance limit..... | 30 |
| Equation 7-Bending stress..... | 31 |
| Equation 8-ASME-elliptic factor of safety..... | 31 |
| Equation 9-Equation for hydraulic horsepower..... | 38 |
| Equation 10-Static factor of safety..... | 48 |

Mission Statement

Our mission at Missing Link Engineering is to take new and existing technologies and implement mergers between problems brought to us by industry. We strive to create innovative solutions that meet the need of a target audience and create powerful, thoughtful solutions that maximize the profitability of our customers. We find the missing link between real world problems and intelligent solutions.



Figure 1-MacDon M155 Self-Propelled Windrower from M155 operator's manual

Introduction

MacDon Industries, LTD. is an OEM (original equipment manufacturer) headquartered out of Winnipeg, Manitoba. They have been world leaders in the technology, innovation and manufacturing of high quality, high performance harvesting equipment for over 65 years now, beginning back in 1949 as Killbery. They currently sell their products in over 40 countries, on six continents as Figure 2 shows. These products range from hay equipment such as rotary and auger header pull-type windrowers, to pick-up and draper headers for combine harvesters. Additionally, they produce a line of self-propelled windrowers designed to operate rotary, auger and draper headers for a variety of uses to producers.



Figure 2-A display of countries with a strong MacDon presence from MacDon’s website

A used self-propelled windrower can cost roughly \$100,000 from a reputable dealer and a new windrower can cost upwards of \$150,000. For many small farming operations it is not economically sound for them to make this kind of investment. Purchasing a tractor after the purchase of an expensive windrower can be a difficult proposition. A farming operation that requires the use of a windrower also requires a tractor to power implements such as small, square and round balers as well as grain augers and other low horse power non-tillage implements. MacDon’s patented Dual Direction® windrowers (U.S. Patent 7159687B2), as seen in Figures 3 and 4, provides the opportunity for a unique solution to this issue. By mounting a drawbar and

hydraulically driven PTO (power take-off) to the header connections the MacDon M155 windrower can be turned into a tractor.

6.3.6.3 Engine-Forward Operation

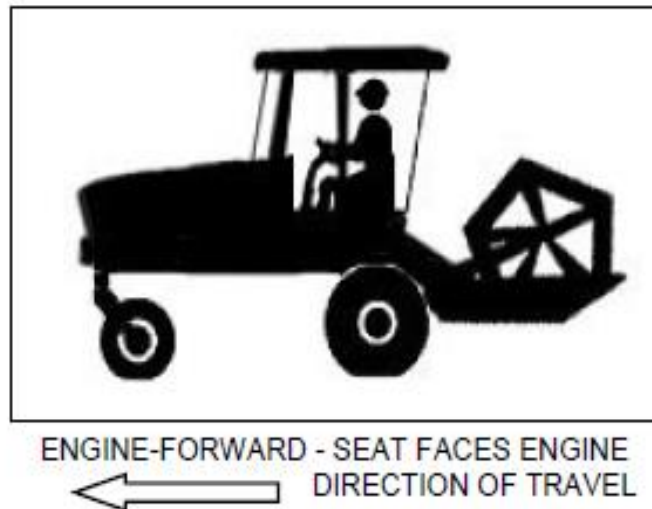

Figure 3-MacDon's Dual Direction® system allows the windrower to be driven engine forward from M155 operator's manual

With this issue in mind, Missing Link Engineering intended to tackle this merger with the following problem statement in mind:

The goal of this project is to create an innovative, cost-efficient, and reliable apparatus to attach to a MacDon M155 windrower, using the attachment points of header on the windrower. This apparatus will make the windrower capable of both powering, via PTO, and pulling small, non-tillage implements while also having a bank of auxiliary Pioneer hydraulic outlets. This attachment would create a year round usage for a piece of equipment that is normally only used for a small portion of the working year.

Missing Link Engineering proposed the addition of a transport kit to the attachment to allow it be pulled to the field by a pickup truck. This would act in place of a three point support setup that would allow the attachment to be free standing when not attached to the windrower but otherwise immobile. We compared the viability of both options in this report.

The scope of the project covers the design, prototyping, and testing of a hitch assembly to attach to an M155 windrower. The hitch assembly was designed with a multi-position drawbar, hydraulically powered PTO, and a bank of hydraulic outlets. The overall cost of components was minimized within MacDon's criteria to make the system more desirable to consumers. Missing Link Engineering explored the feasibility and practicality of the system having a self-contained transport system as opposed to it being free standing for hookup. The deliverables of the project include an apparatus capable of trailering and powering small non-tillage implements with either a transport system or an apparatus to make the apparatus self-supporting when not mounted to the windrower.

The tasks required to complete the entire project are outlined below in Table 1:

Table 1-Task List for Project Completion

| Task | Finish Date |
|---|--------------------|
| Define Client Requirements | 10/01/2015 |
| Research Applicable Patents | 10/15/2015 |
| Establish Multiple Design Ideas | 10/30/2015 |
| Run Calculations/Analysis On Ideas | 11/15/2015 |
| Write Design Presentation | 11/20/2015 |
| Give Fall Presentation to Client | 12/04/2015 |
| Construction of First Prototype | 01/29/2015 |
| Testing and Validation of First Prototype | 02/05/2015 |
| Make Improvements to Prototype | 02/26/2015 |
| Finish Validation of Prototype | 03/18/2015 |
| Write Final Report | 04/13/2015 |
| Give Spring Presentation | 04/28/2016 |

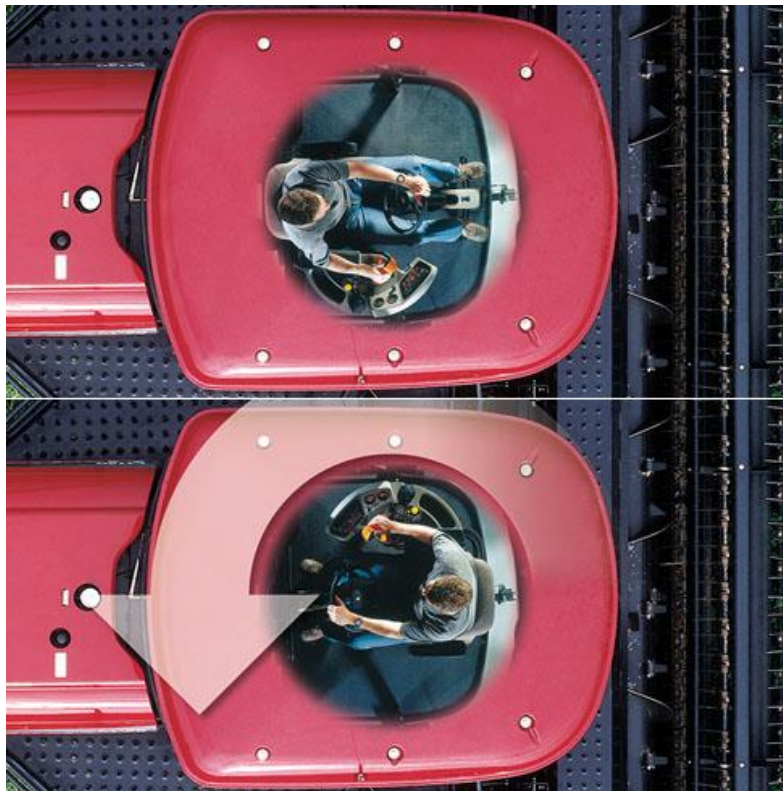

Figure 4-Illustration of changing direction of travel in the windrower from MacDon website

Customer Requirements

For this project, Missing Link Engineering designed an attachment for the operators of an M155 self-propelled windrower that uses the same mounting points as a standard rotary or platform windrower head. This design criteria allowed the attachment to easily trailer and operate small, non-tillage equipment such as hay rakes, grain augers, or balers.

To maximize cost efficiency, we designed the attachment around as many of MacDon's preexisting components as is possible. The use of MacDon's existing part list allowed a decrease in the cost of manufacturing and sourcing of parts. MacDon also required the design to consist of sheet metal thicknesses of 7, 11, 14, and 16 Ga and plate 1/4", 3/8", and 1/2" thick. Bend radii were required to be designed at least 3mm or higher. Additionally, MacDon projected a price of \$3500 on the parts and manufacturing of the attachment. This allowed the client to be able to sell the asset at retail for \$5000. The above budget was used in the cost analysis of parts and overall design scope.

User friendliness will be attained by making the attachment easy to work with. The attachment should be easy to connect to the windrower. The method for transport or free-standing support should be easily done by one operator. The connections to the hydraulics outlets as well as to the hydraulic motor should be able to be accomplished in a similar fashion.

For safe operation and a long working life, all structural components were designed with a static factor of safety of 2 and dynamic factor of safety of 4 as these are the upper boundaries of the clients expectations.

The system will operate with the lift arms in their locked out position to prevent the hitch height from varying during operation. This is the same setup used for when the windrower is pulling a header with a weight box attached, as seen in Figure 5 below. The top link will allow the operator to set the angle of the hitch.



Figure 5-Windrower with weight box pulling a header from M155 owner's manual

The PTO will be powered by the same hydraulics that power a header under normal operating conditions. MacDon asked us originally to possibly make the attachment able to have an interchangeable 540 or 1000 RPM PTO. Later we will go over our decision process as to why we decided that just having a 540 PTO is the only viable option we came up with.

There will also need to be bank of Pioneer hydraulic outlets on our attachment with flow coming from the hydraulic lines that would normally control the functions of a platform header.

The bank will then be controlled by the joystick controls that normally control things like reel raise and lower and fore and aft movement as seen in Figure 6.

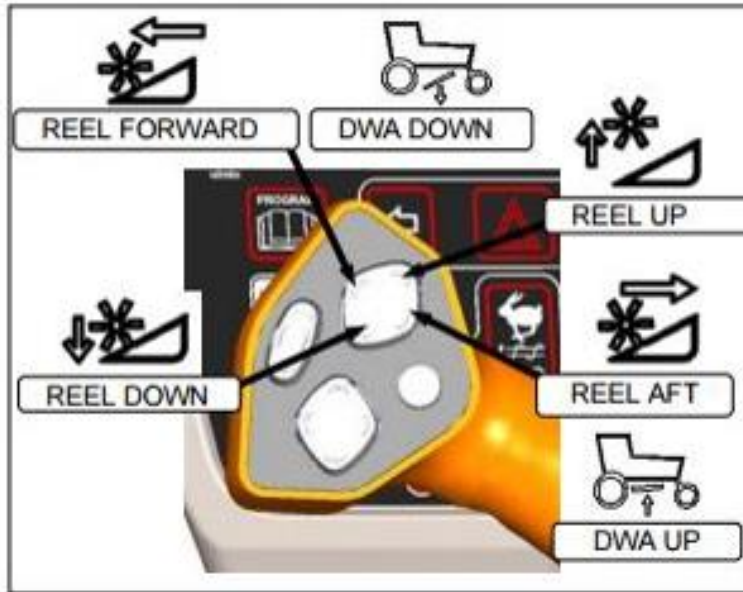

Figure 6-Button layout of hydro joystick from M155 owner's manual

Technical Requirements

One of MacDon’s original requests was to explore the feasibility of a hitch apparatus that would interchange a 540 or 1000 RPM PTO to increase the potential applications of the windrower. This request, while explored, contradicted a higher prioritized requirement of utilizing the MacDon part catalog. None of the current hydraulic motors or gearboxes in their products would facilitate a change in shaft. As such, it was determined an analysis of the largest implement within MacDon’s project scope would need to be analyzed. The largest implement that needed to be powered and pulled was a round bale hay baler. The summary of this analysis can be seen in Table 2. This table shows a compilation of all balers produced by New Holland, John Deere, Vermeer, and Massey Ferguson. The 38 balers sampled varied from 4ft x 5ft to 5ft x 6 ft bale configurations. The average horsepower, excluding 4 balers that required over 100 HP at the PTO, was 61 HP (45.5 KW). The most common power requirement was 70 HP (52 KW). Additionally, 34 of the 38 balers had a 540 PTO option while only 15 balers had a 1000 PTO option. Because of this research a design conclusion was reached. The minimum power output from the PTO should be designed to power at least 70 HP (52 KW) and a 540 PTO would best serve that purpose.

In Table 2 Max Drawbar weight was determined to be generated from a Massey Ferguson 2946/2946A baler and was listed as 1760 lbs by Massey Ferguson or 7829 N. This was the maximum value stated from all of the balers used in the assessment. Max Drawbar Draft was determined to be generated by a Vermeer 504 Pro Silage baler. This value was calculated by multiplying a rolling coefficient of static friction of 0.35 found on engineeringtoolbox.com by the maximum combined base weight of a baler and its heaviest bale and subtracting the drawbar weight with a base weight of 8300 lbs or 36920 N and a max bale weight of 2400 lbs or 10675 N and max drawbar weight of 1400 lbs or 6227 N.

Table 2-Analysis of power requirements for balers

| Baler Analysis | |
|-------------------------|-------|
| Number of brands | 4 |
| Number of balers | 38 |
| Most common HP | 70 |
| Average HP | 61 |
| 540 PTO option | 34 |
| 1000 PTO option | 15 |
| Max Drawbar Weight (N)* | 7829 |
| Max Drawbar Draft (N)** | 14354 |

*Massey Ferguson 2946/2946A

**Vermeer 504 Pro Silage

It is of the utmost importance that the hitch assembly complies with all established international standards that directly apply to it. This will ensure that MacDon can safely and confidently market the assembly to their consumers. Furthermore, this criteria will allow the implement to be compatible with the equipment of all other OEMs who follow those same standards. ASABE, ISO, and OSHA generate the standards that were used in the design process.

The power to wheels is essential to determine the drawbar class used. The power to wheels calculation is displayed in Table 3. The windrower was assumed to be in the low range operating mode. The values for calculation were taken directly out of the Model 155 windrower’s operators manual. Equation 2 and Equation 3 were used in the calculation of the horsepower in Table 7. This power calculated was theoretical as it does not take into account any efficiencies. This calculated power indicated that the attachment would need a category 2 drawbar as stated in ANSI/ASABE Standard AD6489-3.

Table 3-Calculation of power applied to the ground by the wheels

| Power to Wheel Calculations | | | | | | |
|------------------------------------|---------|---------|-----------|-----------|-------------|--------|
| V_m (in ³ /rev) | Q (gpm) | P (psi) | T (lb*in) | T (lb*ft) | n_m (rpm) | P (HP) |
| 4.15 | 40 | 5500 | 3633 | 303 | 2227 | 128 |

Equation 1-Power calculation

$$P = \frac{T * n_m}{5252}$$

Where:

- P=Power (HP)
- T=Torque (ft*lb)
- n_m =speed (rpm)

Equation 2-Hydraulic motor torque

$$T = \frac{\Delta P * V_m}{2\pi}$$

Where:

- T=Torque (lb*ft)
- P=Pressure (psi)
- V_m =displacement (in³/rev)

Equation 3-Hydraulic motor rotational velocity

$$n_m = \frac{Q}{V_m}$$

Where:

- Q = Flowrate (gpm)

Drawbar, PTO placement, and sizing were two of the most important standards that had to be met. ANSI/ASABE Standard AD6489-3 dictated proper drawbar category, category 2 in this case, and dimensions based on power applied to the ground by the tractor or windrower. It also had to adjust its location in relation to the PTO and tractor tires. Drawbar dimensions were needed in order to either augment an existing drawbar for the application or design one completely. ASABE/ISO Standard 500-3 shows proper placement of the PTO in relation to the tires and tractor/windrower geometry. When determining the PTO size from the standards a Type 1 PTO or 540 RPM PTO, which has a maximum power output of 60 KW or 80 HP, was selected to meet the target power of 70 HP. Table 4 shows the auxiliary hole diameter, D and the distance from the auxiliary hole, E. Figure 7 shows a visual representation of the standard.

Table 4-Auxiliary hole diameter and distance to pin hole

| $\varnothing D$ (mm) | Distance, E (mm) |
|----------------------|------------------|
| $21 + 0.8$ | 102 ± 0.8 |

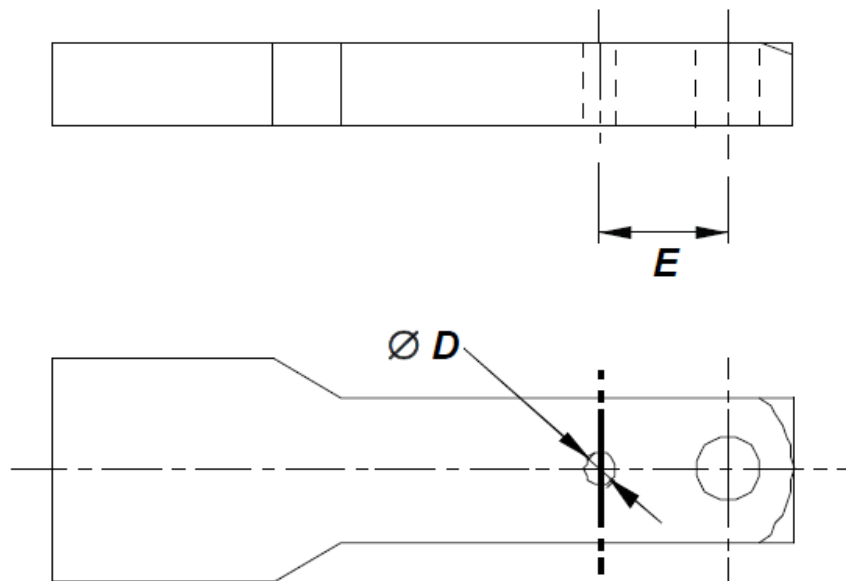

Figure 7-Representation of Table 2 from ANSI/ASABE AD6489-4:2004

The drawbar placement was determined from the PTO itself. Tables 5 and 6 and Figure 8 show the distance from the ground the drawbar needs to be, along with where the pin hole should be located based on the location of the PTO and the position the drawbar is in. This location has both vertical and horizontal distances from the PTO shaft as shown below in Figure 8. Along with this the maximum static vertical load that can be applied to the drawbar at the pin hole is based on position. The minimum distance from the ground the drawbar needs to be was 330 mm, while the maximum was 500 mm. For this design, being closer to the 500 mm point will be more

practical as the likely application of the windrower with our attachment will require a proficient level of clearance i.e. baling a bushy crop.

Table 5-Location of drawbar relative to PTO for regular drawbar position

| Height of drawbar, S (mm) | U min. (mm) | T (mm) | Maximum static vertical load, F (kN) |
|---------------------------|-------------|--------------|--------------------------------------|
| 330 to 500 | 250 | 400 ± 10 | 15 |

Table 6-Location of drawbar relative to PTO for short drawbar position

| Height of drawbar, S (mm) | U min. (mm) | T (mm) | Maximum static vertical load, F (kN) |
|---------------------------|-------------|--------------|--------------------------------------|
| 330 to 500 | 250 | 250 ± 10 | 22 |

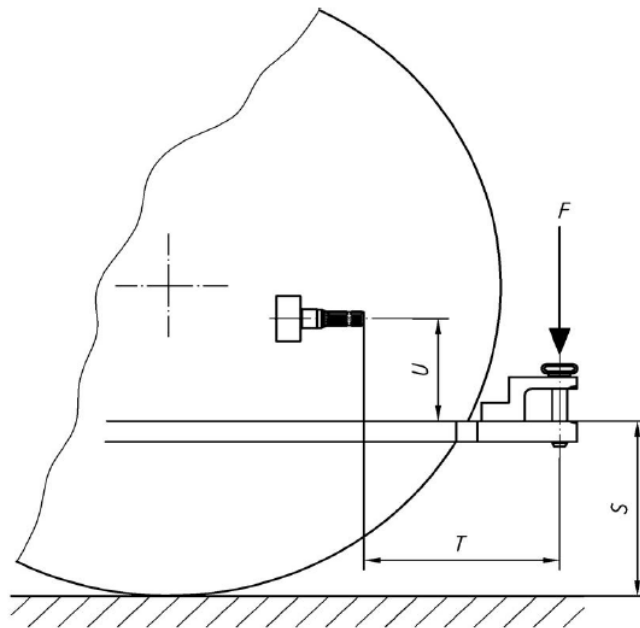

Figure 8-Representation of Table 4 from ANSI/ASABE AD6489-4:2004

Key
F vertical load

Figure 9 represents where the pin hole should be based on the grown radius of the rear tires. This dimension is a standard minimum distance of $L = 25$ mm. This standard along with the standards above for the pin hole relative to the PTO should all be met seamlessly. This dimension corresponds to the minimum distance from the rear most part of a tractor, which is defined in the standard as the rear of the maximum grown tire diameter, to the drawbar. In our case, this rear most part was the end of the lower lift arms of the windrower as they stuck past the drive tires.

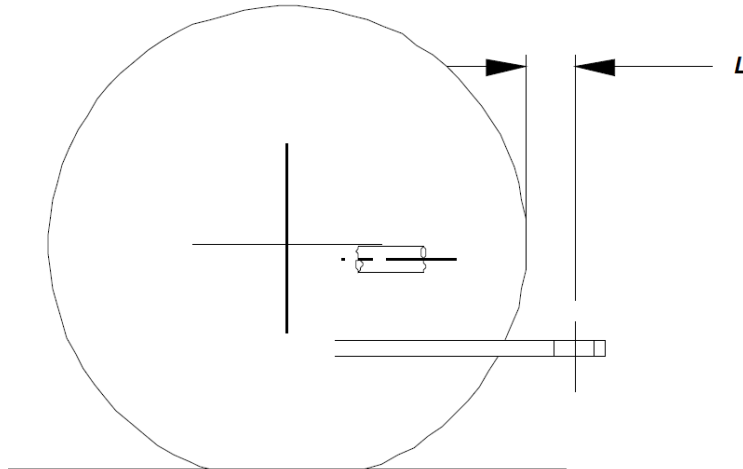

Figure 9-Location of Pin hole relative to rear tires from ANSI/ASABE AD6489-4:2004

Table 7 shows the dimensions for a Category 2 drawbar. Many of the dimensions listed were not used, given the drawbar used will not have a clevis as shown below in Figure 10. Some of the dimensions like the width of the drawbar, A, thickness, B and F, and the end of radius of drawbar and clevis, R will be maximum values as shown in the Table 7. Pin diameter, C1, G, and throat depth, J, were all minimum values used in the design. The pin hole diameter had a variability of +0.8 mm and -0.25 mm. The values not used in the design of the drawbar included, height of the raised piece relative to the bottom, H and W. These values were only necessary if it was determined that the design fabricate a drawbar for the project.

Table 7-Drawbar Specifications Based on Category 2 Drawbar

| | | |
|--|----------------|-----|
| Drawbar width, A (mm) | Maximum | 90 |
| Drawbar thickness, B (mm) | Maximum | 52 |
| diameter, C (mm) | +0.80 -0.25 | 33 |
| Pin diameter, C1 (mm) | Minimum | 30 |
| F (mm) | Maximum | 45 |
| G (mm) | Minimum | 210 |
| Height, H (mm) | Minimum | 70 |
| Throat depth, J | Minimum | 80 |
| End radius of drawbar and clevis, R (mm) | Maximum | 55 |
| W, (degrees) | Minimum | 20 |

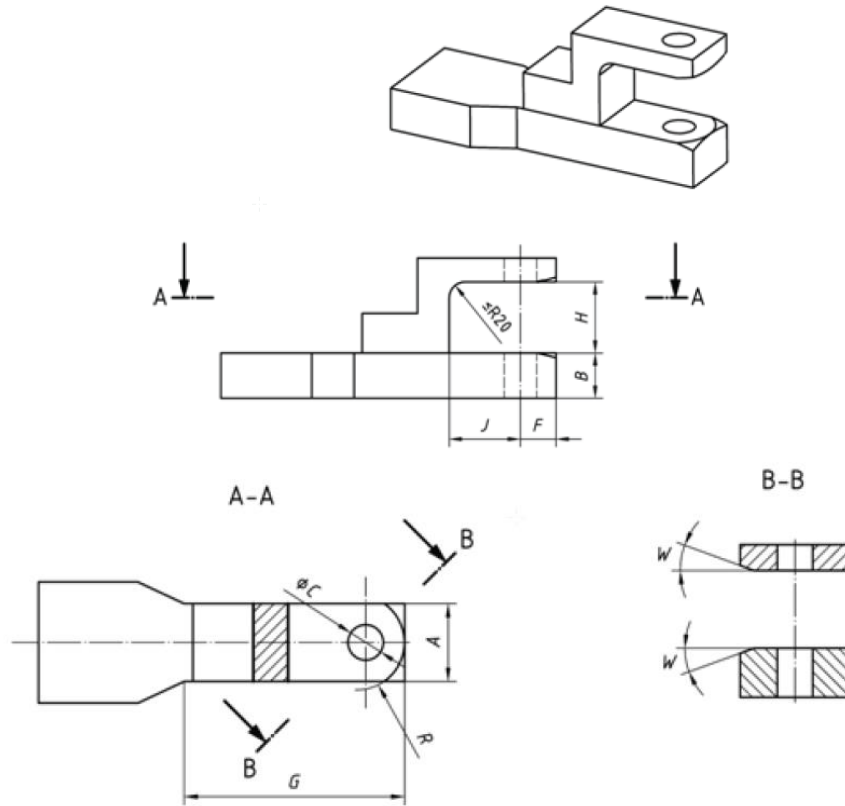

Figure 10-Drawbar Specifications Based on Table 6 from ANSI/ASABE AD6489-4:2004

Table 8 shows the minimum clearance of the top of the pin relative to the midpoint of the PTO. This is represented by V in Figure 11. The clearance plane shown in figure 11 is represented by the number 1.

Table 8-Clearance Distance of Pin

| |
|---|
| PTO drive shaft clearance, V minimum (mm) |
| 100 |

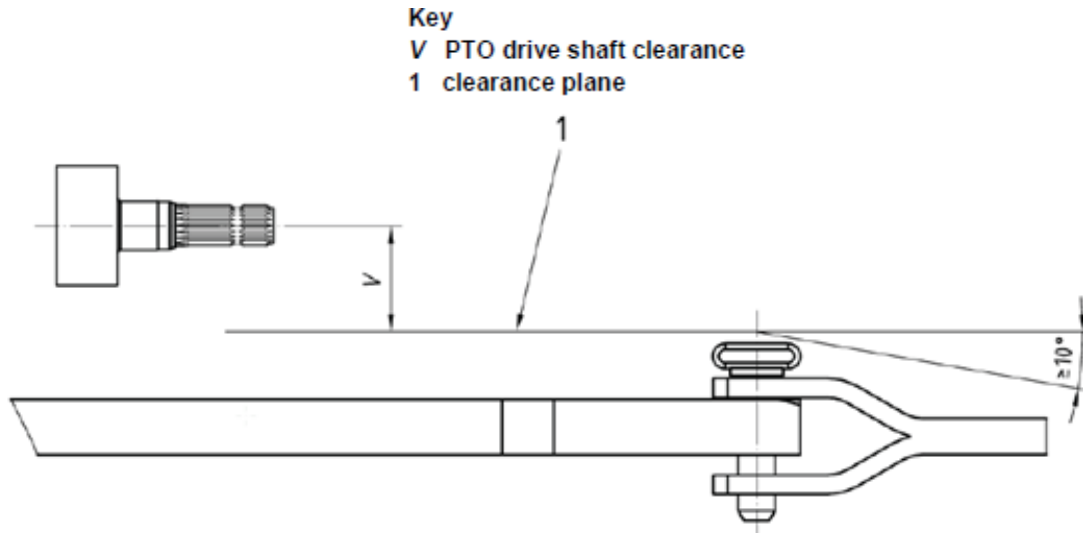

Figure 11-Representation of Table 8 from ANSI/ASABE AD6489-4:2004

The PTO placement on the windrower was another vitally important aspect of the design. If not properly placed complications can arise. Table 9 shows the minimum and maximum distances of the PTO box relative the bottom of the rear tires. h_{min} , shows the height of the bottom of the PTO box with reference to the bottom of the rear tires, while h_{max} shows the height of the top of the PTO box relative to the bottom of the rear tires. The centerline of the tractor or windrower is represented by the number 2 as seen in Figure 12, while the number 1 shows the track width of the rear tires. These standards are shown given the fact the PTO box is centered on the centerline with tractor or windrower. As shown in Figure 12 the distance from the center of the PTO to the edge of the box shall not exceed 25 mm, and should be the same distance on either side of the PTO shaft. These distances are based off of the type 1 PTO given in the ASABE/ISO Standard 500-3.

Table 9-Distance of PTO Box Relative to Bottom of Tire

| h_{min} (mm) | h_{max} (mm) |
|----------------|----------------|
| 480 | 800 |

Dimensions in millimetres

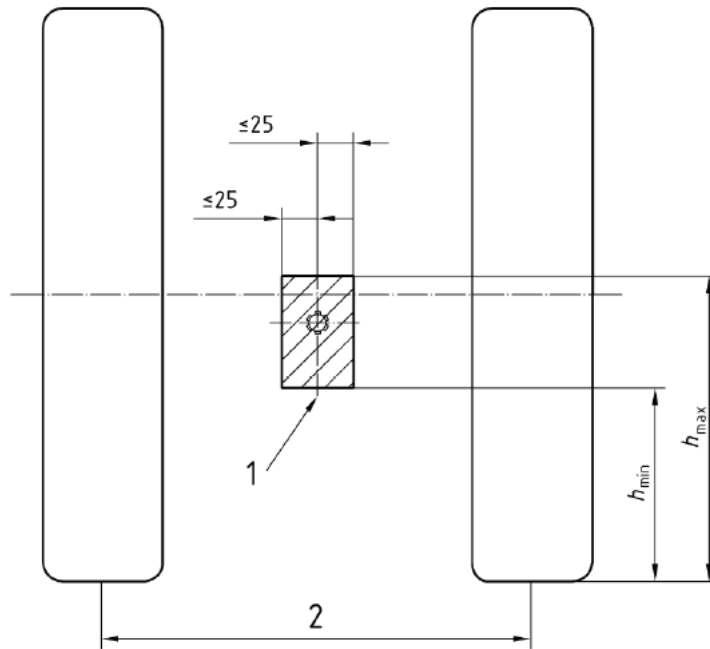

Key

- 1 centre line of tractor
- 2 track width

Figure 12-Distance of PTO Box Relative to Bottom of Rear Tires from ASABE/ISO 500-3:2014

The PTO master shield for the PTO shaft is another highly important aspect of the design. Without this preventative tool, risk of injury can arise. Specifications for PTO shields are outlined in ASABE/ISO Standard 500-1. The shield for the PTO is a preventative measure to protect the operator and machinery from grave situations that can possibly happen when operating farm equipment. The PTO master shield geometry is shown in Figure 13 which is listed below. The shield dimensions are based off the type 1 PTO which are used for the drawbar standards and PTO placement standards. Shown in the figure is the optional shape of the shield to a certain extent. The top of the shield can either be more round or more straight with a sharper angle to connect the top of the shield. On the sides of the shield the shield can either be straight down with a rounded edge or tapered back towards the PTO shaft with a harder angle back towards the windrower. These optional shapes are shown below in Figure 13. Table 8 shows the dimensions of the shield based on the type 1 PTO. This includes minimum and maximum dimensions, with variable dimensions also. The hole for the safety chain in Figure 13 is shown by the number 1.

Table 10- PTO Shield Dimensions

| | | |
|---------------|---------|-----|
| A (mm) | minimum | 76 |
| α | minimum | 60° |
| β | minimum | 50° |
| γ | minimum | 45° |
| SRr (mm) | maximum | 76 |
| K (mm) | minimum | 70 |
| $m \pm 5$ mm | | 125 |
| $n \pm 5$ mm | | 85 |
| $p \pm 10$ mm | | 290 |
| r (mm) | maximum | 76 |

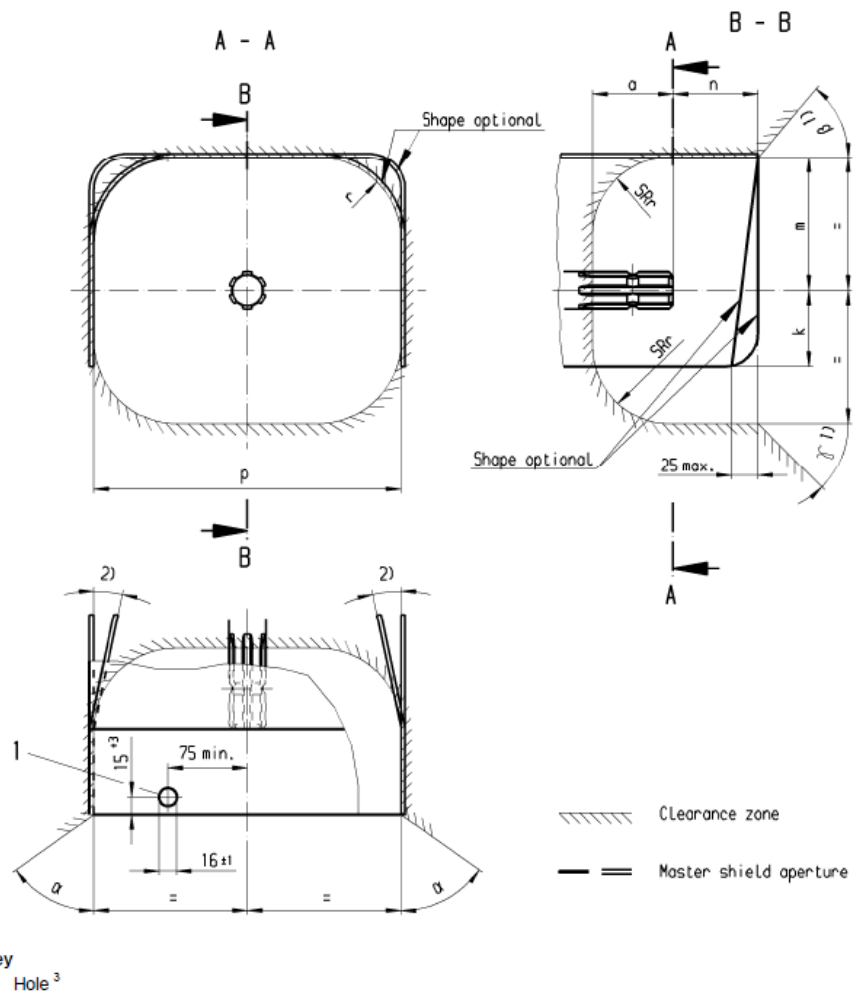

Figure 13-PTO Shield Schematic from ASABE/ISO 500-1:2014

Figure 14 shows the area that auxiliary hydraulic outlets should reside within at the rear of the tractor in accordance with ANSI/SAE S366.2 May 2004. This area means that we will likely have to run lines from our primary connection to the windrower's hydraulic block on the operator's right hand engine rear side to another plate located closer to the PTO with female hydraulic couplers. This will ensure that the attachment can connect to any standard piece of equipment without having to add hydraulic extension hoses.

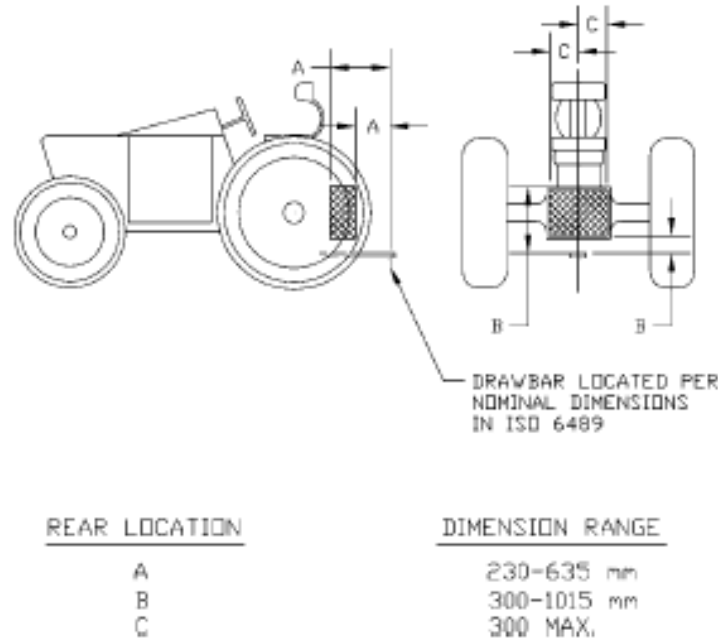
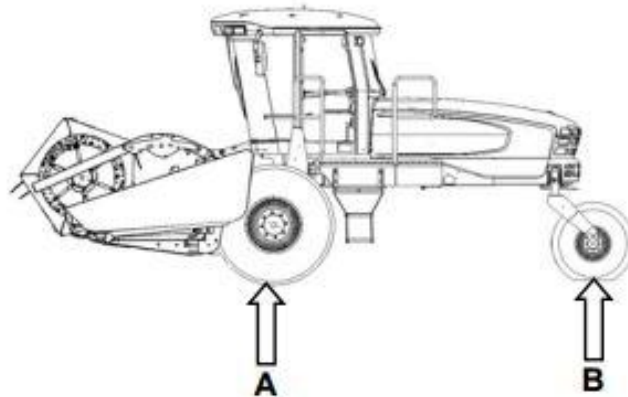

Figure 14-Figure for dimensions of hydraulic outlet from ANSI/SAE S366.2 MAY2004

Table 11 shows a table from the M155's owner's manual displaying the maximum allowable weight on each axle. This is important because it gives us the maximum weight that the front axle can support safely. By subtracting the minimum weight on the front axle from the maximum weight we determine that our maximum combined vertical force of our attachment and the weight placed on the drawbar from an implement has to stay under 8680 lbf. This is taken into account both in the design of our attachment and when considering the largest implements that can be pulled by it. The value from Table 5 of Maximum static vertical load for short drawbar configuration of 22 kN or 4946 lbf can be viewed as our potential maximum drawbar load. Subtracting this value from the previously stated maximum combined of hitch attachment and implement of 8680 lbf means that our attachment cannot exceed 3734 lbf.

Table 11-Weight Maximums on Axles from M155 Owner's Manual

- To prevent machine damage and/or loss of control, it is essential that the machine be equipped such that weights are within the following limits:



| | | LB | KG |
|--|----------------|--------|--------|
| MAX GVW (includes mounted implements). | | 21,500 | 9,750 |
| MAX CGVW (includes towed and mounted implements). | | 23,100 | 10,480 |
| WEIGHT "A" ON BOTH DRIVE WHEELS. | MAXIMUM | 18,750 | 8,500 |
| | MINIMUM | 10,070 | 4,570 |
| MAX WEIGHT "B" ON BOTH CASTER TIRES. | | 6,050 | 2,750 |

Product Research

In order to ensure that there were no preexisting solutions to the issue we are confronting we performed research into everything that could be relatable. This includes mostly patent research. The main results of our research showed, however, that there was nothing similar enough to our project to warrant any issues with potential lawsuits.

Figure 15 depicts a tractor quick hitch that was developed by International Harvester Company in 1970 and is detailed in U.S. Patent 3531140A. The quick hitch is the most similar apparatus to what our project is trying to accomplish, in that, it is an attachment designed to pull implements while being attached to its power source, a tractor, via a three point connection. They have been used by all major OEMs since their inception. From, this we gain an idea of what type of basic structure we can model our attachment like.

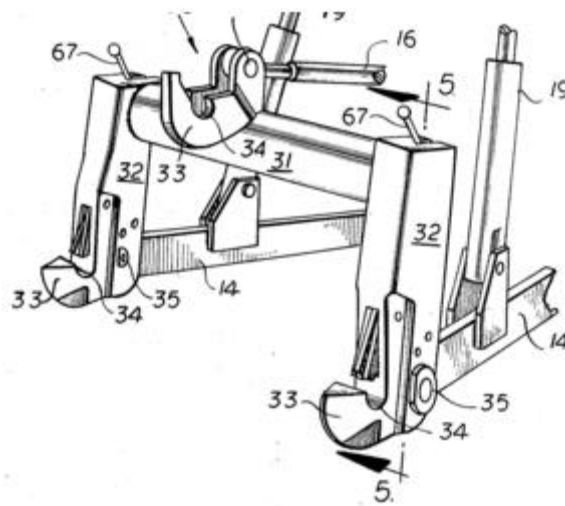

Figure 15-A quick hitch detailed in U.S. Patent 3531140A

Figure 16 shows the application of U.S. Patent 5031394A. It is a windrower attachment that attaches to a bi-directional articulating tractor making the tractor a self-propelled windrower. This eliminates the need for a self-propelled windrower but means that you must have a bi-directional tractor which is not a common piece of equipment. It provides little help in solving the goal of our client

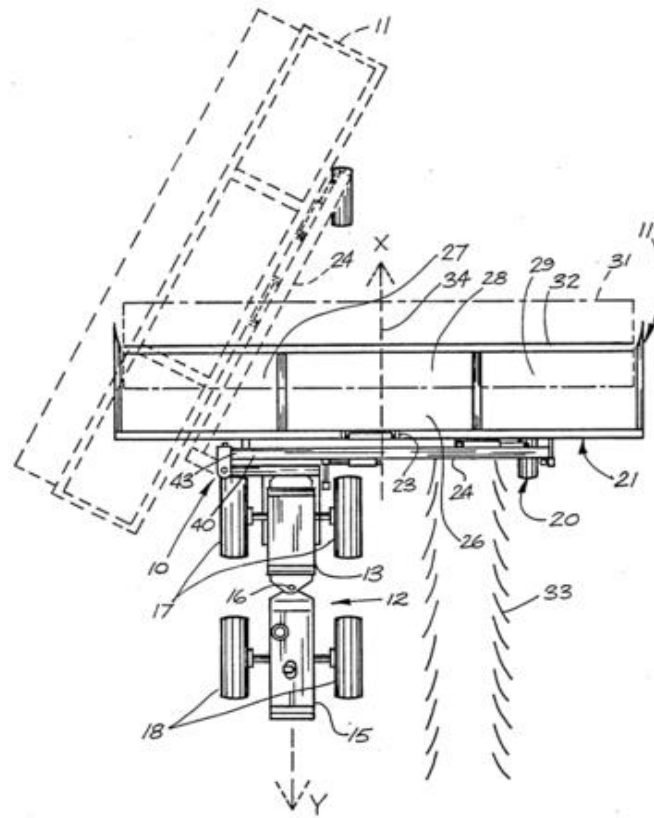

Figure 16-Application of U.S. Patent 5031394A

Self-propelled sprayers are built quite similarly, from a drive train perspective, to windrowers. Figure 17 shows U.S. Patent 6460643B1 which consists of an apparatus that converts a self-propelled sprayer into a windrower. It uses the idea that the sprayer is a front boom sprayer. This entails removing the front boom and using the hydraulics and lift mechanism from the boom to run a windrower header. This would eliminate the need for a windrower and makes the sprayer a multi-purpose piece of equipment. Self-propelled sprayers cost typically, considerably more than a windrower. We also found no purchasable systems of this apparatus on the market. If they were, it could be assumed that they would be through an OEM who manufactures front boom self-propelled sprayers.

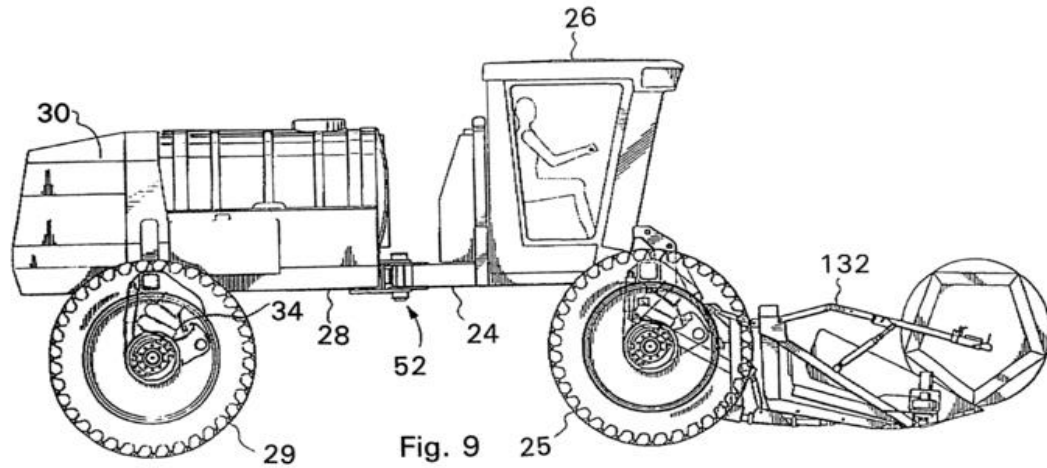

Figure 17-Application of U.S. Patent 6460643B1

Skid steers are essentially a motor connected to hydraulic motor with outputs for a drive train and various implements, similar to a windrower. Figure 18 shows U.S. Patent 20040098885A1 which consists of a skid steer attachment of a stump grinder. This attachment is hydraulically driven similarly to how the PTO of our attachment will be powered. From this we can gain insight into the way to properly power the PTO's hydraulic motor and possibly the organization of the hoses going into the pump.

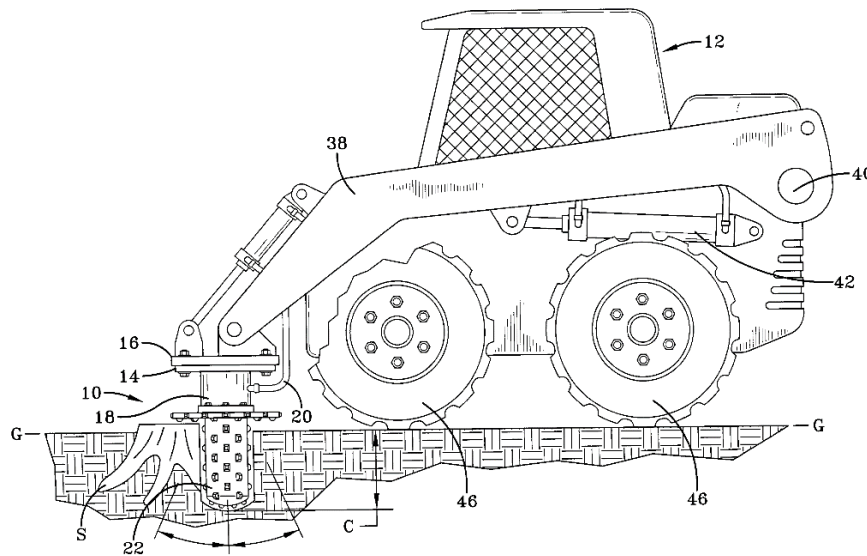

Figure 18-Application of U.S. Patent 20040098885A1

Project Impact

There are no inherent environmental, global, or societal risks associated with this project as it entirely a small scale mechanical endeavor. The major impact of this product is economic. Essentially, this product has the potential to increase the appeal of MacDon's windrower to a market that previously may have not considered the viability of one. By being able to market their windrowers as multi-purpose pieces of equipment that can do the functions of a normal tractor at a fraction of the cost of buying a windrower and tractor they will increase the marketability of their windrowers.

Other aspects to be considered are those to do with safety. With any piece of agricultural equipment there are inherent safety risks, procedures, and precautions that need to be taken into account. The most dangerous aspects of this project are the high pressures that the hydraulic components will be operated at along with the safety issues with the PTO shaft. Additionally, several pinch points will have to be addressed in relation to the swinging drawbar and transport system.

For hydraulic safety we will have to ensure that all connections use the proper fittings and that each hose is rated for the pressure that we will be applied to it. For the PTO we will have to build or buy a swinging shield that meets ASABE standards. For all possible pinch points and the other safety areas we should procure the proper safety stickers illustrating the possible safety hazards. Additionally, to reduce the risk injury from pinch points the operator's actions when interacting with the attachment will be especially taken into consideration during design. This ranges from what is required of the operator to do during the connection of the attachment to the windrower to where the operator is supposed to stand while doing so.

Design Concepts

Operation

The attachment has to be designed for ease of use to make the transition from using a windrowing header to pulling an implement effortless for the operator. When operating the attachment, this will be achieved by using the same buttons as during normal windrowing. The header engage/disengage switch in Figure 19 will be used to engage and disengage the PTO drive of the attachment. The hydraulic bank will be activated using the joystick controls as was pointed out in Figure 6. The



Figure 19-Header Engage/Disengage Switch from M155 operator's manual

Connecting hydraulics for both the hydraulic bank and powering the PTO will be made easy by the use of the hydraulic coupling plates used on the D65 header as seen in Figures 20, 21, and 22.

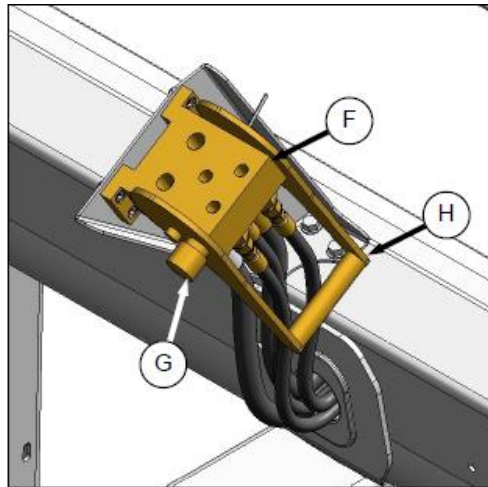

Figure 20-Auxiliary hydraulic coupling plate from D65 owner's manual

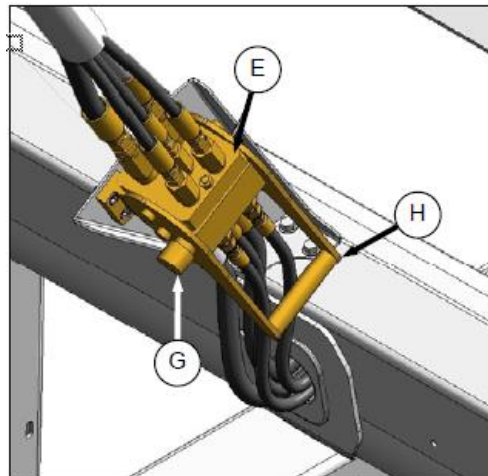

Figure 21-Auxiliary hydraulics attached to coupling plate from D65 owner's manual

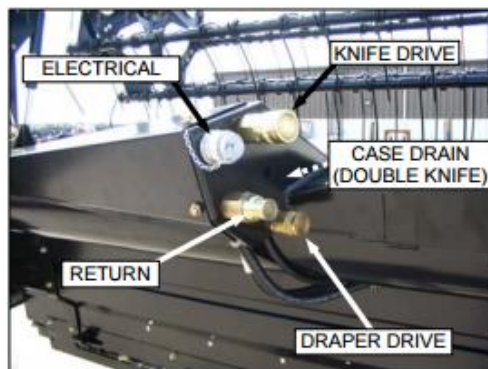

Figure 22-Full time flow hydraulic hookups which will be used for PTO power from D65 owner's manual

Figure 23 shows the attachment with hydraulic connection plates colored in yellow, from Figure 20, and orange, which is similar to Figure 22). The connection on the right side is

MacDon's assembly B5457 that consists of a block valve that the hydraulic hoses from the right side of the windrower latch onto with a handle. Hoses will then run to the purple plate that is the mounting plate for the gearbox. These will attach to the Pioneer quick coupler. The yellow plate on the left side of the attachment has four holes in it to allow for the four connections to the hydraulic motor. Fittings will be mounted solidly to the plate and hoses will run from the plate to the motor.

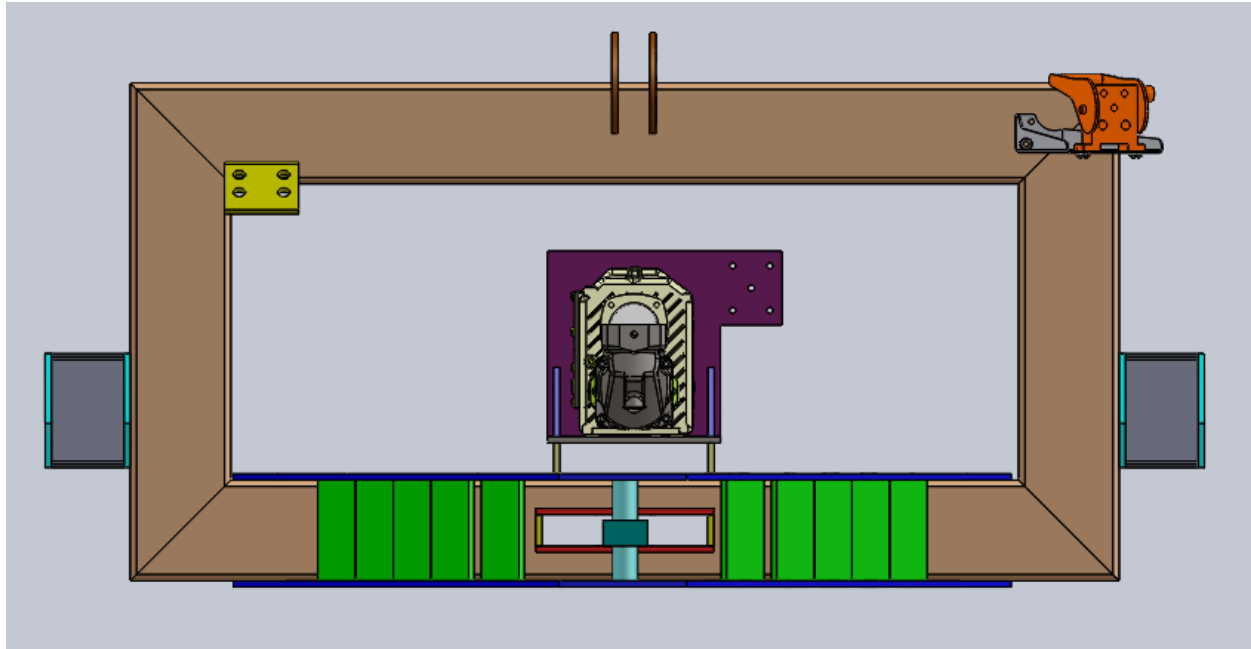

Figure 23-Rear view of attachment with hydraulic outlet connections

Figure 24 shows the type of Pioneer quick coupler the attachment will have. These use a half inch line and fittings. These operate at up to 3000 psi. These couplers have O-ring seal sleeve-lock sockets. All hydraulic lines will be high-pressure reinforced-rubber hose.



Figure 24- Pioneer quick coupler from McMaster-Carr

In order for the attachment to run while in engine forward mode, the windrower must first be adjusted at several key operating points. First the pressure on both the reel and drapper drives should be adjusted to 4300psi. This can be accomplished using the testing protocol set forth in the M155 owner's manual. The engine will need to run in the upper half of its operating speed in order to power the drive for both the reel and knife drive pumps. Several manipulations of the

solenoids must be made in order to allow the existing on board computer to allow engine forward and the header drive to function.

Frame

The initial approach for designing this drawbar attachment for the swather was to use a tractor 3-point quick hitch type design to mount it to the header lift arms and center link. After information was gathered as to what balers weigh that would commonly would be used on this apparatus then came the drawbar calculations.

Before any stresses were calculated the dynamics of the tractor and baler as an assembly had to be calculated. The baler itself in the static position also had a set of calculations that needed to be performed.

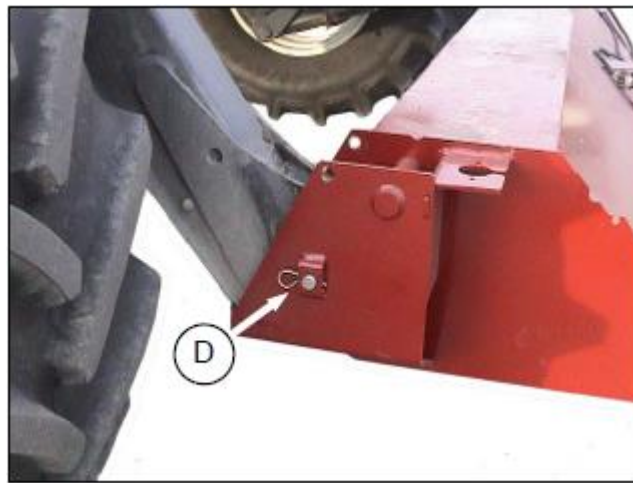

Figure 25-Side view of MacDon weight box from M155's owner's manual

The heaviest baler that was researched was a Vermeer 605 Super M. Its static weight was 8,300 lbs with a drawbar weight of 1,650 lbs and it produces a bale with an average weight of 2,400 lbs. With these weights in mind the basic static calculations were made to find the forces on the hitch and the support wheels with a full bale chamber. These values were computed with the assumption that when the bale chamber is full, the full weight of the bale is directly above the baler wheels. The equations used for these calculations are displayed in Equation 4. These equations produced a resultant of zero vertical drawbar force with a full bale chamber.

Equation 4-Static force equations

$$\begin{aligned}\sum F_x &= 0 \\ \sum F_y &= 0 \\ \sum M &= 0\end{aligned}$$

Where

- $\sum F_x$ = sum of forces in the x direction (N)

- $\sum F_y$ = sum of forces in the y direction (N)
- $\sum M$ = sum of the moments about the baler wheels (N*m)

The dynamics of this particular assembly consisted of estimating the force it takes to get the baler moving and also the horizontal force the baler would exert on the drawbar at it max weight i.e. full bale chamber. While moving a baler with a full bale chamber isn't typical this situation was used because it simulated the worst case scenario for forces that would be exerted on the drawbar. The equations detailed below in Equation 5 were used to calculate the extreme condition.

Equation 5-Force to begin moving a fully loaded implement

$$\sum F_x = \mu_s N$$

Where:

- μ_s = static coefficient of friction (unitless)
- N = normal force exerted on the wheels (N)

The equation above defined the force that it would take for the baler to start motion. In this case, the static coefficient of friction because the wheels are assumed to be rolling when pulling the baler rather than sliding, this by definition calls for the use of the static coefficient of friction. Using this equation resulted in a force to get the baler moving of 14094.5 N or 3,168 lbs. This completed the dynamics portion of the calculations for the drawbar. This however was just a portion of the calculations.

After this came the calculations of sizing the drawbar and support to get the requested safety factor. The engineers at MacDon requested a safety factor of 3 or better. The initial calculations were done with the drawbar mounted in a pure bending situation. Under further investigation however if the drawbar was mounted in a position where the mounts are at a 45 degree angle this increased the strength of the drawbar and apparatus considerably in the bending moment. These calculations were performed using a machine design process as modeled in the book Shigley's Mechanical Engineering Design. This process was modeled out in design for the stress-life method. Using this process involved picking a material, taking an initial size as a starting point, and then calculating from there. This process included a set number of "k" factors which accounted for different variations in the material and hardware. These factors include surface finish, profile of hardware, temperature, reliability, and a final factor that includes any other factors that needed to be accounted for. The previously stated "k" factors were used in the following equation:

Equation 6-Endurance limit

$$S_e = S_e k_a k_b k_c k_d k_e k_f$$

Where:

- S_e = endurance strength (ksi)

- S_e' = endurance strength calculated from the ultimate strength (ksi)
- k_a = surface condition factor
- k_b = profile condition factor
- k_c = type of loading factor
- k_d = temperature factor
- k_e = reliability factor
- k_f = general “catch all” factor for any remaining conditions

From this came the stress calculations to find the safety factor. To start these stress calculations the drawbar force was estimated as previously stated, then, found the stress that would be on the drawbar and apparatus using the strengths of materials equation.

Equation 7-Bending stress

$$\sigma = \frac{Mc}{I}$$

Where

- σ = bending stress (ksi)
- M = bending moment (N*m)
- c = radius of profile (m)
- I = second moment of area (m⁴)

Using equation 7 it was estimated to have produced a stress of 57.95 MPa for pure bending and 11.03 MPa in partial bending and partial shear.

To find the safety factor for this drawbar the ASME-elliptic equation was used. Equation 8 stayed closest to the empirical test data curve that had been collected over years of testing and data collection for drawbars.

Equation 8-ASME-elliptic factor of safety

$$n = \sqrt{\frac{1}{\left(\frac{\sigma_a}{S_e}\right)^2 + \left(\frac{\sigma_m}{S_y}\right)^2}}$$

Where

- n = safety factor (unitless)
- σ_a = amplitudal stress (ksi)
- σ_m = midrange stress (ksi)
- S_e = endurance strength (ksi)
- S_y = yield strength (ksi)

Amplitude stress is the distance from bottom to top of the wave form made by the changing forces exerted on the apparatus. Midrange stress is the distance from the middle of the bottom to the top of the waveform formed by the force exerted on the apparatus. The waveform was modeled by force that the baler exerts on the drawbar when it is being pulled in the field. For simplification to be able solve equations and sizing materials the force is modeled as a sine wave. Thus causing the amplitude and midrange waves in the safety factor equation.

After solving for the initial safety factor, the safety factor determined whether the size was correct or not. With the initial assumption of 6"x6" and .25" wall thickness, it was determined that the safety factor was not nearly enough to be able to sustain usage in the field. With this in mind the iteration process began. The second iteration used 8"x8"x.25" wall thickness which resulted in a safety factor of 2.43 in purely bending conditions and a safety factor of 12.78 in partial bending and partial shear conditions. This result was conclusive that the triangular mounted method as previously stated was a better design. Table 12, Table 13, and Table 14 show the calculations behind the determinations.

Table 12-Pure bending factor of safety calculations

| ALL UNITS IN METRIC | | Square tubing mounting style, with squared mounts | | | | | | | | | | | | | |
|--------------------------------------|-------------|---|----------|----------|-------------------------------------|-------|-------|------------------------|-------|-------|---|------------|--------------------------|-----|--|
| tractor model | IH 1086 | S_e | S_e | S_{ut} | k_a | k_b | k_c | k_d | k_e | k_f | material is A500 Grade C | | | | |
| tractor power | 84.3 kw | 140.93 | 213.7375 | 427.475 | 0.81 | 1 | 1 | 1 | 0.814 | 1 | S_{ut} | S_y | | | |
| baler model | Vermeer 605 | assumed initial size .1524x.1524 m | | | $S_e = S_e k_a k_b k_c k_d k_e k_f$ | | | | | | σ_a | σ_m | Mpa | Mpa | |
| baler weight w/ bale | 40270.04 N | approx inch dimensions 6"x6" | | | | | | | | | 57.95 | 28.97 | | | |
| coefficient of static friction | 0.35 | | | | | | | K_t | K_t | q | ASME- elliptic | | | | |
| drawbar force(vertical) | 40270.04 N | | | | | | | 1 | 1 | 0.8 | n_f FOR BENDING 2.43 | | n_f FOR SHEAR ∞ | | |
| wheel force(vertical) | 14094.514 N | | | | | | | $K_f = 1 + q(K_t - 1)$ | | | $\left(\frac{\sigma_a}{S_e}\right)^2 + \left(\frac{\sigma_m}{S_y}\right)^2 = \frac{1}{n_f^2}$ | | | | |
| force to get baler moving(horizotal) | 11.26 km/hr | | | | | | | | | | | | | | |
| speed of baling(approx) | | | | | | | | | | | | | | | |

Table 13-Split bending and shear factor of safety calculations

| | | <i>Square tubing mounting style with triangular mounts</i> | | | | | | | | | |
|---------------------------------------|-------------|--|---|------------|--|----------------|------|--|-----------|--|--|
| tractor model | IH 1086 | | | | | | | | | | |
| tractor power | kw | 84.3 | | | | | | | | | |
| baler model | Vermeer 605 | | | | | | | | | | |
| | | 40270.04 | | | | | | | | | |
| baler weight w/ bale | N | | σ_a | σ_m | | ASME- elliptic | | | | | |
| | | | 15.60 | 7.80 | | | | | | | |
| | | | Mpa | Mpa | | n_f | 9.04 | | n_f | | |
| coefficient of static friction | | 0.35 | | | | FOR BENDING | | | FOR SHEAR | | |
| drawbar force(vertical) | N | 0 | $\left(\frac{\sigma_a}{S_e}\right)^2 + \left(\frac{\sigma_m}{S_y}\right)^2 = \frac{1}{n_f^2}$ | | | | | | | | |
| | | 40270.04 | | | | | | | | | |
| wheel force(vertical) | N | | | | | | | | | | |
| force to get baler moving(horizontal) | N | 14094.514 | | | | | | | | | |
| | | | | | | | | | | | |
| speed of baling(approx) | km/hr | 11.26 | | | | | | | | | |

Table 14-Split bending and shear factor of safety calculations using flat plate

| | | <i>Flat plate mounting style with triangular positioning</i> | | | | | | | | | |
|---------------------------------------|-------------|--|-------|-------|----------|-------|----------|-------|-------|-------|------------|
| tractor model | IH 1086 | | | | | | | | | | |
| tractor power | kw | 84.3 | S_e | S_y | S_{ut} | k_a | k_b | k_c | k_d | k_e | k_f |
| | | | 90.51 | 190 | 380 | 0.81 | 0.85 | 0.85 | 1 | 0.814 | 1 |
| baler model | Vermeer 605 | | | | | | | | | | σ_a |
| | | 40270.04 | | | | | | | | | σ_m |
| baler weight w/ bale | N | | | | | n_f | 9.035524 | | | | 30.97 |
| | | | | | | | | | | | 15.48 |
| | | | | | | | | | | | Mpa |
| coefficient of static friction | | 0.35 | | | | | | | | | S_{ut} |
| drawbar force(vertical) | N | 0 | | | | | | | | | S_y |
| | | 40270.04 | | | | | | | | | 380 |
| wheel force(vertical) | N | | | | | | | | | | 210 |
| force to get baler moving(horizontal) | N | 14094.514 | | | | | | | | | Mpa |
| | | | | | | | | | | | Mpa |
| speed of baling(approx) | km/hr | 11.26 | | | | | | | | | |

The attachment is loosely based on a 3 point quick hitch to be mounted to the windrower. Figure 27 shows a hoop going up to the top center link to keep the attachment stable. The top center link was designed to pass over the top square tube. This arrangement was made to increase the weld length which gave greater shear strength. The 2 side mounts were based off the weight box that Mac Don used on their windrowers when necessary to keep all the wheels of the windrower on the ground. They are also designed with extra material to overlap the square tubing on the frame to increase the weld length thus increasing the strength of the attachment points.

In this report two different options for the frame are displayed. The first is a somewhat rounded hoop. The intention behind this configuration was to reduce the stress concentrations in the attachment and improve stress flow so that it distributed throughout the whole attachment. The other option was a squared attachment with two vertical beams and two horizontal beams that accomplish the mounting of the attachment.

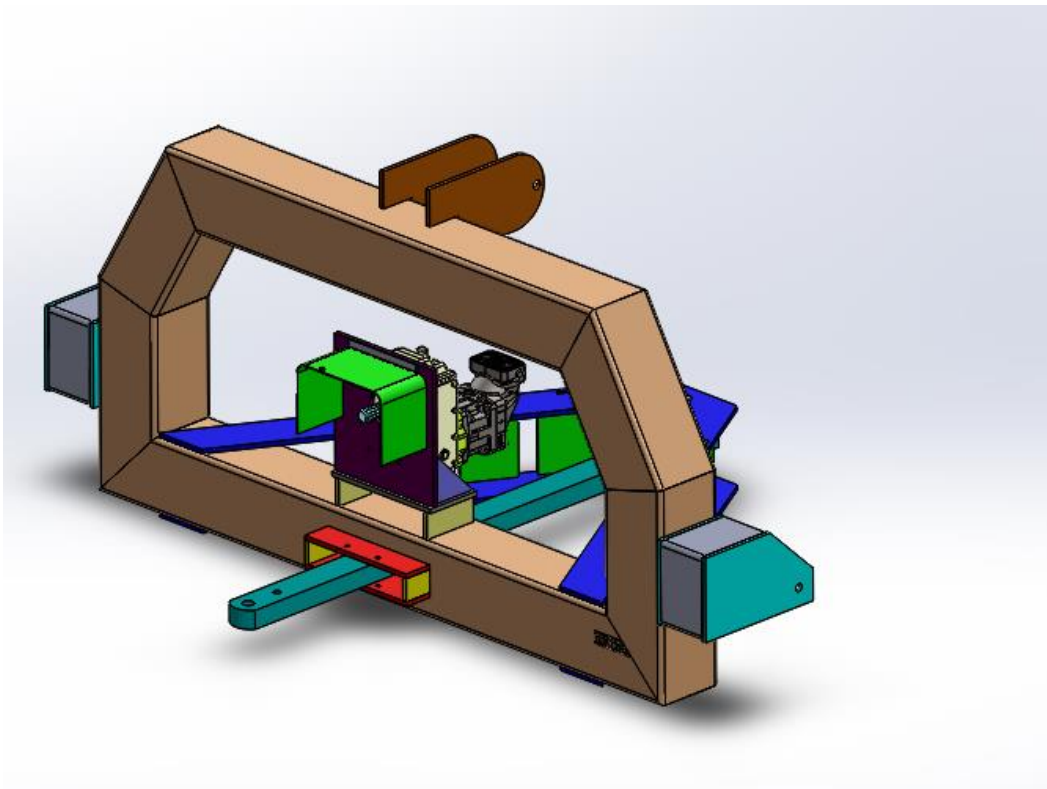

Figure 26-Rounded frame, plate mounting

Figure 26 shows the first of three preliminary designs. In all three of the designs the standards for ASABE drawbars were used. This resulted in two options for the drawbar, a long spacing and short spacing. The long spacing included the implement clevis hole at 400mm from the end of the PTO output. The short spacing was 250mm from the end of the PTO output. This option resulted in the configurations as shown in the figures (Figure 26, 27) where the drawbar projected out past the frame by a substantial amount. All three frame designs showed the drawbar passing through the bottom square tube rather than over or under the main frame. The drawbar through the frame offered practical mounting of the drawbar, constraint of the drawbar when using the swing function, and constraint in the vertical direction. The drawbar box was made so that the drawbar passes through with half inch welded plate surrounding. This was done in order to increase the strength of the tubing due to cutting a hole in the tubing caused a stress concentration.

The design from figure 26 is based off square tubing for the frame with half inch plate, in blue, for the mounting of the drawbar and also the mounting of the attachment to the machine. We like this design because it uses lots of flat plate and minimizes square tubing. These plates

are reinforced with vertical gussets as you can see in the figure. This is for strength in the plates but also for when pulling the implement to keep down the flexing and bending of the plates causing a failure. The frame is somewhat rounded like it is in this design because we believe it will help with stress flow throughout the attachment and cut down on stress concentrations in the frame. This is however more fabrication work and poses a problem when welding together because a jig has to be made so that when welded together the pieces of tubing are square with each other. This design also poses another problem for the mounting of the hydraulics onto the frame.

Figure 27 shows a different design option that we considered during our preliminary design ideas. In this design it is the same as in Figure 26 except for drawbar mounting. The drawbar is mounted using square tubing, in dark red, with flat plate, in pink, instead of all flat plate. Initially this was thought to be a good design, however, under further investigation we discovered a very large design flaw. This flaw is having to cut the square tubing. We would have to cut the square tubing because we wanted to offer the option of short or long drawbar configurations and to offer that would necessitate cutting a hole in the square tubing to accomplish this. Also we would have to cut the square tubing to offer the swing function of the drawbar. If we did not do this, to offer the swing function would necessitate an exorbitantly long set of square tubes and also a very large set of square plates. These would be so large that it would make the whole attachment very impractical to use.

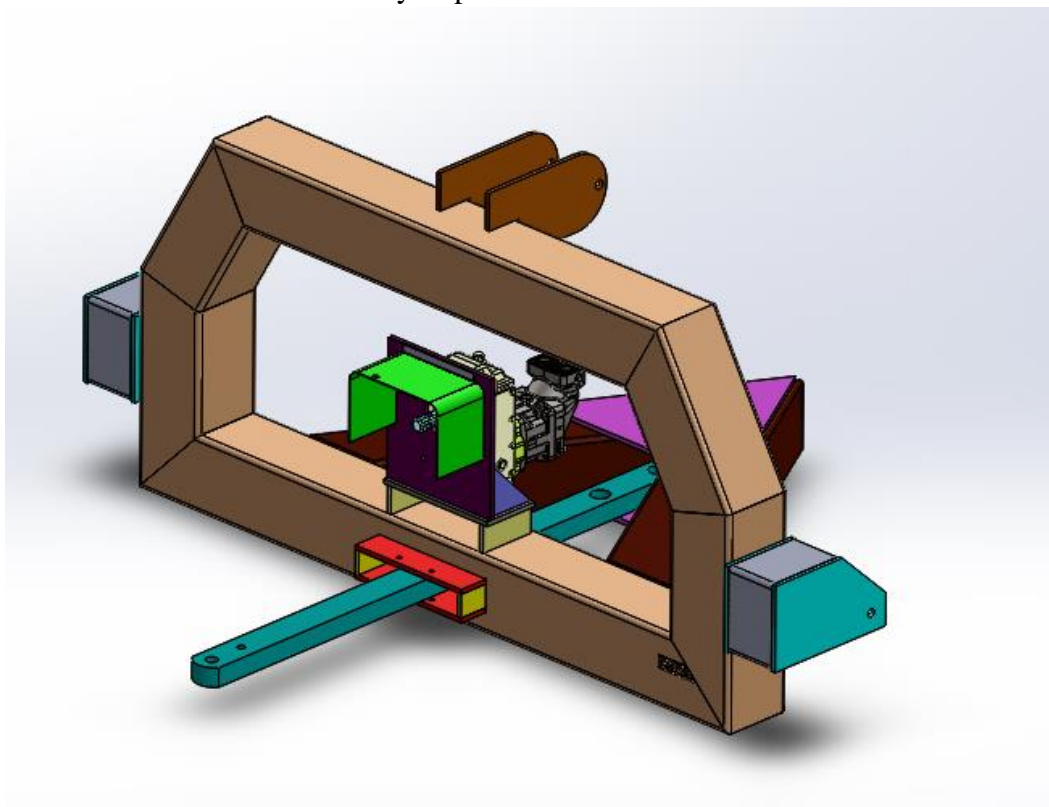

Figure 27-Rounded frame, tubing mounting

The third design concept is Figure 29. This concept uses the flat plate, in blue, mounting style for the drawbar and instead of a rounded mainframe a squared mainframe. This style mainframe offers advantages over the rounded style mainframe, the first being ease of manufacturability. Manufacturability is easier because it's joining four pieces of square tubing together which is much easier to do than having to create a jig then join the pieces together. With this design it also makes mounting of the hydraulics on the sides of the frame easier because the sides are vertical rather than at an angle. This design still allows for the preferred half inch flat plate configuration as well. With the designs we have this design in total is the preferred design because of its simplicity. This design the only problem we have found with it thus far is that using a square frame there could be stress concentrations at the corners where the square tubing meets because they meet at right angles rather than smoother less abrupt angles. This could cause a stress flow problem in mainframe.

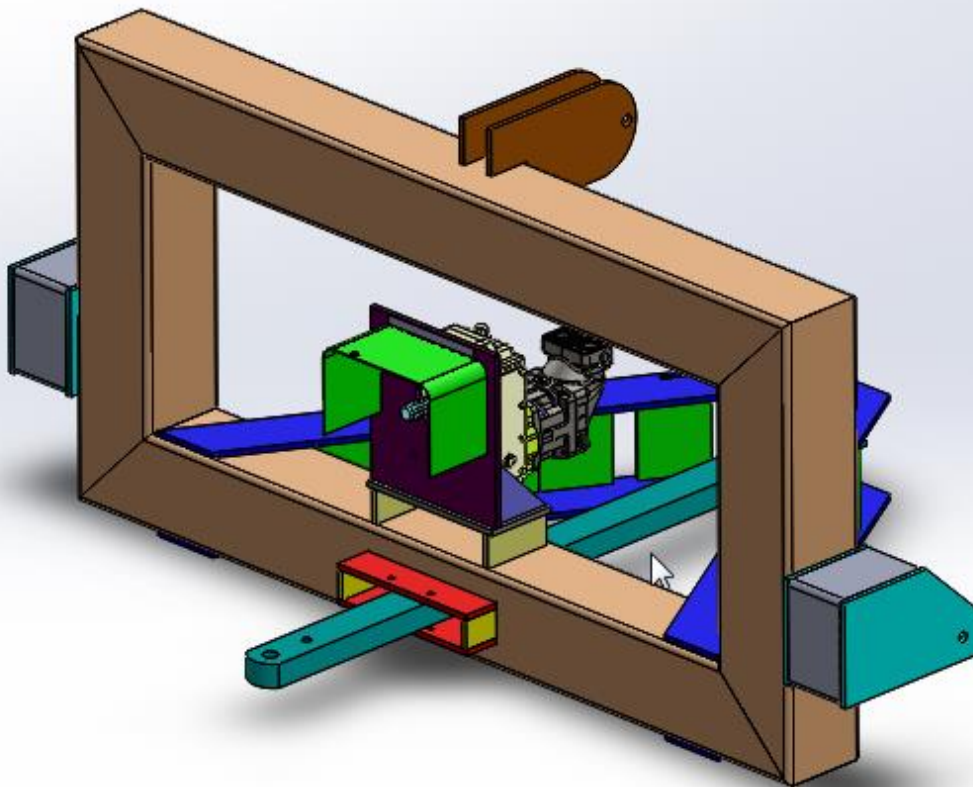

Figure 28-Square frame, plate mounting

PTO

The PTO will be powered using a piston hydraulic motor. MacDon has previously used similar designs on its pull type rotary headers. The 2012 and prior type made use of a Parker

Hannifin motor and a Comer gearbox in order to convert the tractor PTO power to hydraulic power, which was then run to the rotary. This system was designed for a 540rpm PTO. Making use of a similar concept and a 540 rpm shaft the system can be used for our attachment design. The Parker pump can operate over a variety of speeds and by varying our windrower controls to a calibrated point we can achieve our required power and speed. Figure 29 is our model with Figure 31 displaying the associated gearbox. The performance curve for the pump is displayed in Figure 30. As shown, the performance for the pump was assumed to be approximately 95% for further calculations. The Comer gearbox has a 1:3.8 gear ratio. The pump rpm to output will be calibrated to the flowrate controls on the windrower. Table 12 shows the maximum output of the gearbox which was within the target output.

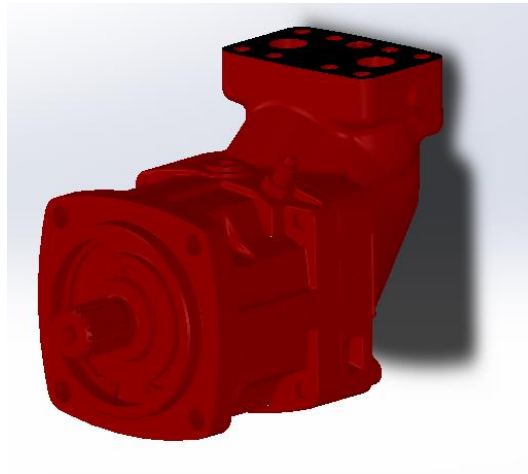

Figure 29-Parker Hannifin Pump Model

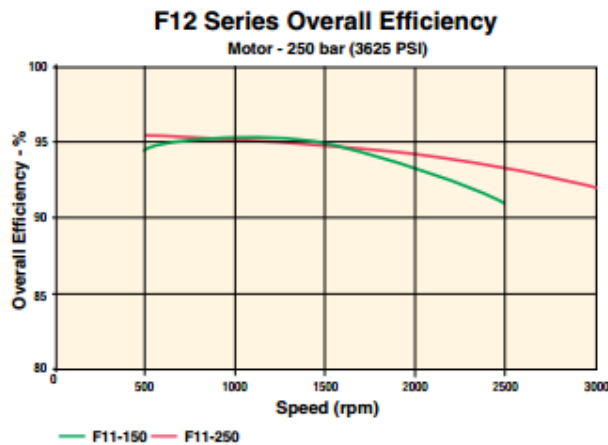

Figure 30-Parker Hannifin Pump Operation Speed

To know how much power can potentially be generated by the windrower the theoretical power for the hydraulic circuits for the knife, reel, and draper were calculated. Results are shown in Table 15 and Equation 4 was used to calculate power. Values for each circuit were gathered from MacDon. The predicted horsepower exceeds the minimum design value of 70 determined in the baler section. The power requirements at the drive were back calculated in table 16. The

pump speed without the gearbox had to be 1419.3 rpm. This justified the use of a gearbox in order to transfer power at lower speeds.

Equation 9-Equation for hydraulic horsepower

$$HP = \frac{Q * P}{1714}$$

Where:

- HP = Horsepower generated (hp)
- Q = hydraulic flowrate (gpm)
- P = pressure (psi)

Table 15-Theoretical hydraulic horsepower

| Hydraulic Power | | | |
|-------------------------|----------------|--------------------|------------|
| Pump | Flowrate (gpm) | Pressure (psi) | HP |
| Knife | 26 | 4300 | 65 |
| Reel | 13 | 4300 | 33 |
| Draper | 13 | 4300 | 33 |
| | | Theoretical | 130 |
| Assumed Loss 25% | | Predicted | 98 |

Table 16-Operation Requirements

| Power Requirements | | | | |
|---------------------------|----------------|----------------|-------------------|------------------|
| Minimum Power (HP) | Pressure (psi) | Flowrate (gpm) | Flowrate (cc/min) | Pump Speed (rpm) |
| 70 | 4300 | 30.0 | 113543.4 | 1419.3 |



Figure 31-Comer A-649A Gearbox

Table 17-Gearbox Rating

| COMER NUMBER | RATIO | RPM | HP | KW | SHAFTS | |
|--------------|-------|-----|----|------|----------|-------------|
| | | | | | Input | Output |
| 9.649.003.00 | 1:3.8 | 540 | 76 | 55.9 | 1 3/8 Z6 | 1 16/32 Z15 |

The second option mirrors the later generation design of the pull type rotary header. A Bosch Rexroth pump is attached directly to the tractor PTO. The use of a spline converter would create a merger to the required output shaft. The pump requirements are shown below. The displacement required for the correct speed is 28 cc. This sized the pump to the A2FM28 pump. The power requirements for this option are displayed in table 14. Figure 31 is the pump without a backflow control mounted to the backside.



Figure 32-A2FM28 Bosch Pump

Table 18-Bosch Pump

| Power Requirements | | | | |
|--------------------|-------------------|-----------------|-------------------|------------------|
| Maximum Power (HP) | Pressure (psi) | Flowrate (gpm) | Flowrate (cc/min) | Pump Speed (rpm) |
| 70 | 4300 | 30.00 | 113543.4 | 4055.1 |
| Pump Rating | | | | |
| Max Pressure (psi) | Displacement (cc) | Max Speed (rpm) | Efficiency | Max Flow (gpm) |
| 5800 | 28.1 | 5800 | 0.9 | 46 |

Of the two options the Parker Hannifin pump was determined to be the best option. It allowed the most flexibility, and the mounting for the gearbox provided a location for a PTO shield.

The PTO gearbox that was chosen for the attachment has to be properly mounted and secured while still being serviceable. Figure 32 shows the concept developed for mounting the PTO gearbox. The mount will be welded to the main frame of the attachment directly above the drawbar. This mount consists of two main plates as seen in the purple and silver of Figures 32, 33, and 34. The purple plate has 6 holes to use the mounting holes of the front of the gearbox and 5 holes on the left hand side to allow for mounting of the Pioneer outlets. This will place the outlets within the envelope described in ANSI/ASAE S366.2 May 2004. The silver plate has 4 holes to use the mounting holes on the bottom of the gearbox. A hole must be cut in the right side of the purple plate as can be seen in Figure 33 to allow for access to a port in the front of the gearbox. Gusset plates, colored purple in the figures, were added for additional support. The face of the plate is wide enough to allow for proper attachment of a PTO shield.

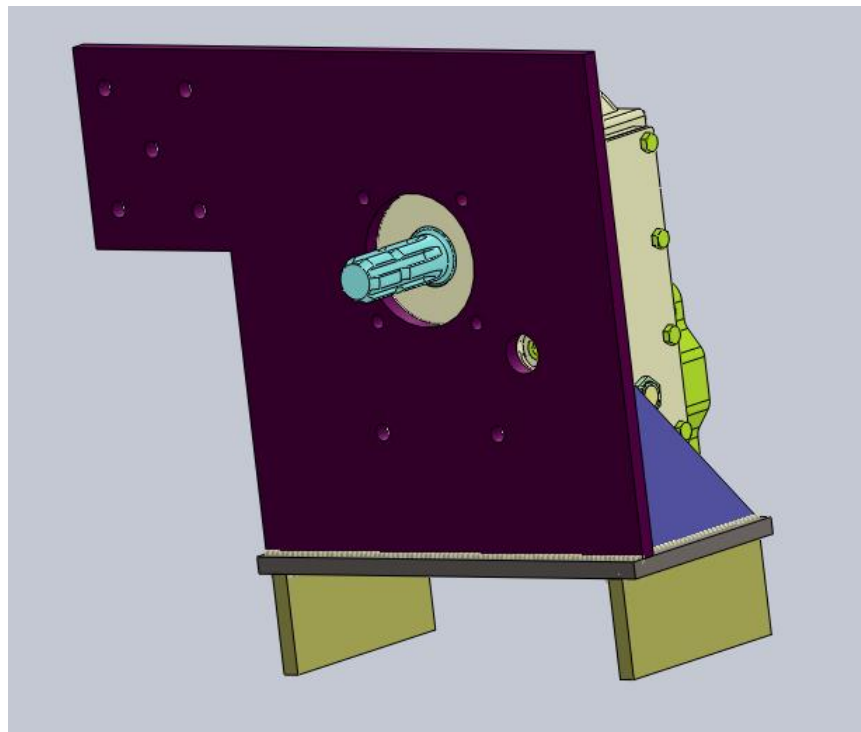

Figure 33-PTO gearbox mount

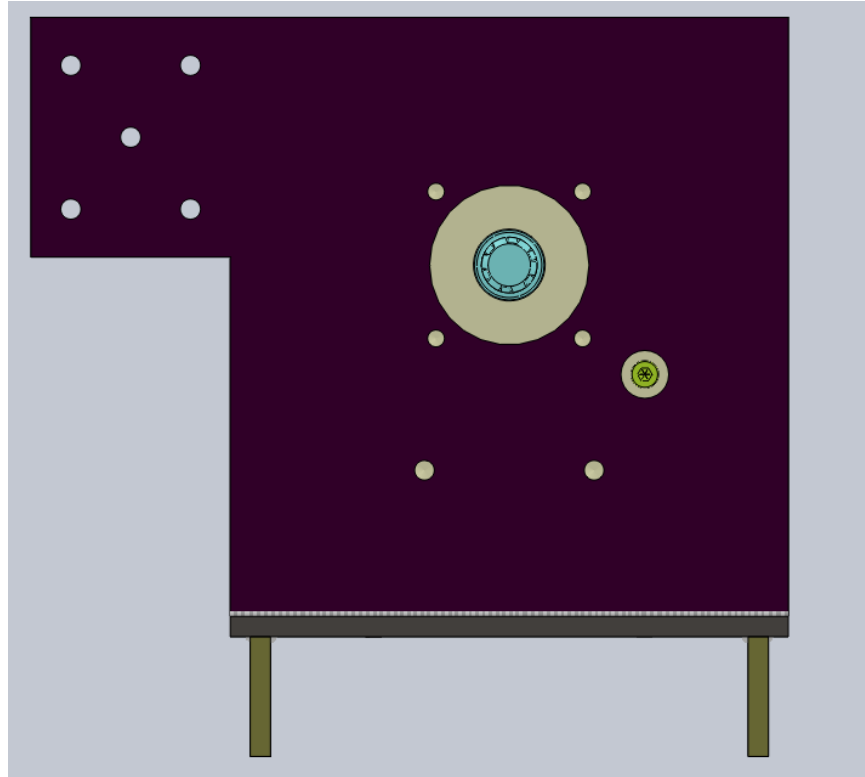

Figure 34-Front view of PTO gearbox mount

Figure 34 shows the lower stands, in dark green, which will attach to the main frame of the attachment. These plates are 75 mm tall to allow for adequate room to both insert bolts from below and fit a socket under the plate to tighten them. This height also ensures that the PTO is at the proper height above the drawbar.

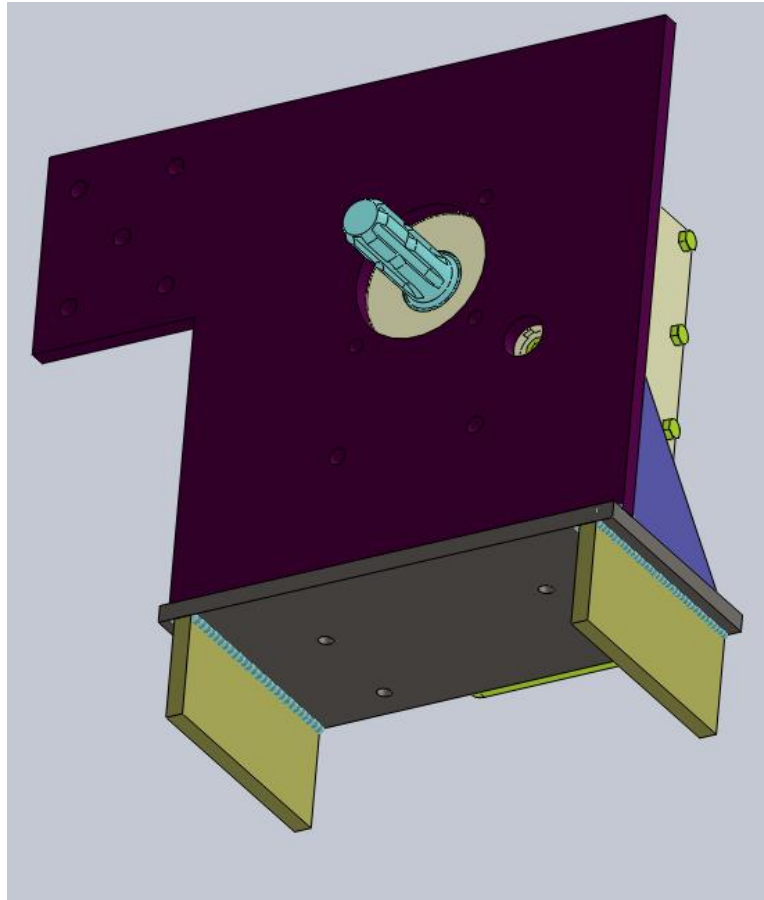

Figure 35-Lower view of PTO gearbox mount

Transport/Self Support

The attachment must have some way of supporting itself when not attached to a windrower and to keep it at the proper height to ensure that connecting it to the windrower is as easy as possible. On a normal three-point implement this would be accomplished by having anywhere from two to four pipes/legs that pin into place and allow the implement to stand freely and self-support when unattached from a tractor. Once these implements are attached to a tractor the legs are retracted upwards and pinned into place. The proposed prototype sits, on the ground, with the mounting holes of the lower attachment boots at close to 11” from the ground and the mounting holes of the lower lift arm’s holes sit at 8” off of the ground when fully lowered. Because of this and the fact that the attachment will not tip over when sitting on the ground a free standing support system would not be necessary. As discussed earlier, Missing Link Engineering proposed to MacDon the potential of adding a self-contained transport system to our attachment.

Missing Link Engineering tasked two groups of ambitious freshman interns to develop concepts for the transport wheels and hitch for the self-contained transport system. Both groups were asked to use as many preexisting MacDon components as possible in developing their design concepts. Group 1 was tasked with working on transport wheel concepts and Group 2 was

asked to develop hitch concepts. Both groups were given a generic SolidWorks model of the proposed attachment to work off when developing their concepts.

Group 1 developed a hinging axle design which can be seen in Figures 35 and 36. The design involved using an axle attached to a square tubing frame which pivots on two pinned clevises and was pinned into both transport position, as seen in Figure 35, and in folded operation position, as seen in Figure 36. This design would potentially need a cylinder of some sort to raise and lower the wheel structure.

Group 2 developed a hitch system that would slide over the drawbar of the attachment as seen in Figure 37. This design uses a clevis manufactured by MacDon (part #113536) and a piece of 3 gage square tubing for the main frame. They placed an adjustable jack on it to allow it to be free standing when not connected to anything. The group was also tasked to come up with a way to store the hitch when it was not attached to the drawbar. Their solution is displayed in Figure 38 where they mounted the hitch to the face of the attachment above the PTO.

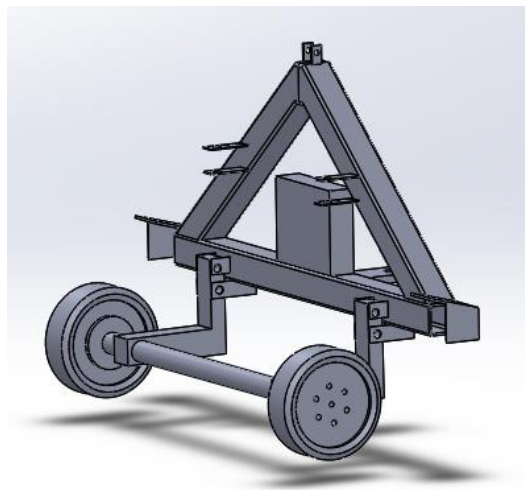

Figure 36-Freshmen group 1 transport wheel proposal

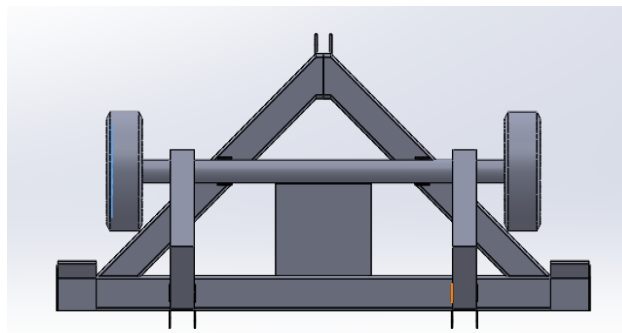

Figure 37-Freshmen 1 group transport wheels folded

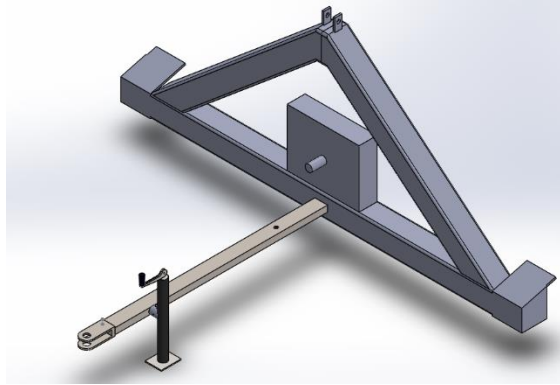

Figure 38-Freshmen group 2 hitch concept in transport configuration

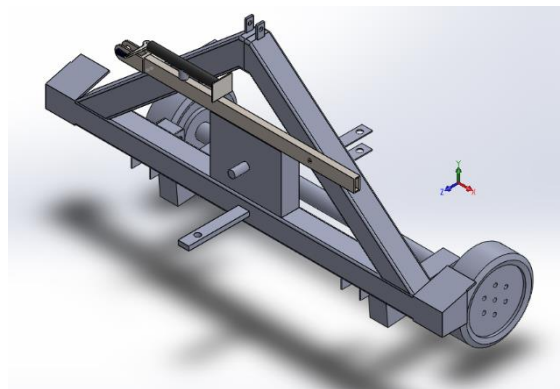

Figure 39-Freshmen group 2 hitch concept mounted for storage

After considering our intern's ideas it was decided to look at the idea of a self-contained transport system from a different angle. The designs above did not utilize components from MacDon and required a large amount of physical requirements for the operator. The prototype needed to eliminate the possibility for an extra hydraulic cylinder or linear actuator to be added to the system for lifting and lowering the wheels. To make the use and deployment of wheels and a hitch easy on the operator, the team searched deeper into MacDon's preexisting support wheels for their header's transport system. The most appealing options were found in the slow-speed transport system of the D65 header. Figure 39 displays a stabilizer wheel that is raised and lowered via a handle meant to be moved by one operator. Figure 40 shows a set of caster wheels located at the front of a D65 header used for ensuring the header stays off the ground during field operation and act the front axle and hitch point during road transport. Figure 41 shows how a hitch is attached to the caster wheels in Figure 40. The proposed concept of how wheels would be mounted to the attachment is displayed in Figure 42.

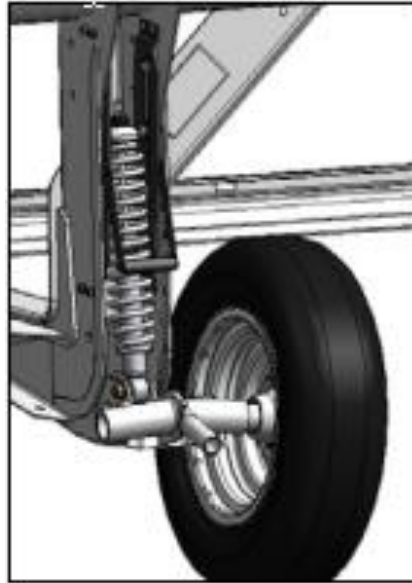
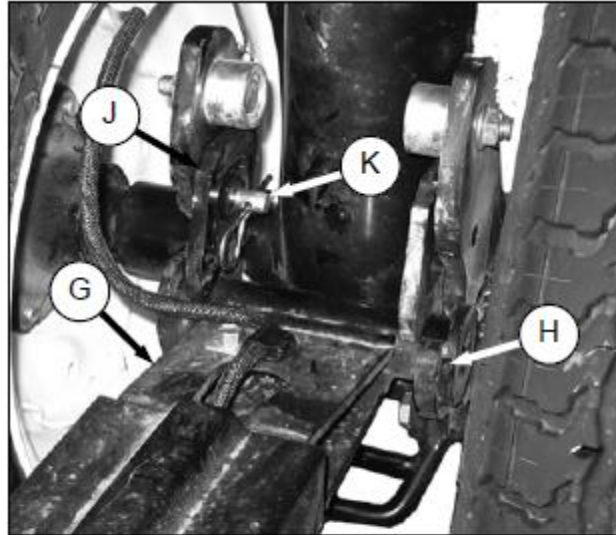

Figure 40-Stabilizer wheel from D65 header operator's manual



Figure 41-Front caster, slow-speed transport wheels from D65 header operator's manual



1. Position end (G) of the aft section onto front wheel hook (H).
2. Push down until latch (J) captures the end (G).
3. Secure latch (J) with clevis pin (K).

Figure 42-Hitch connection process from D65 owner's manual

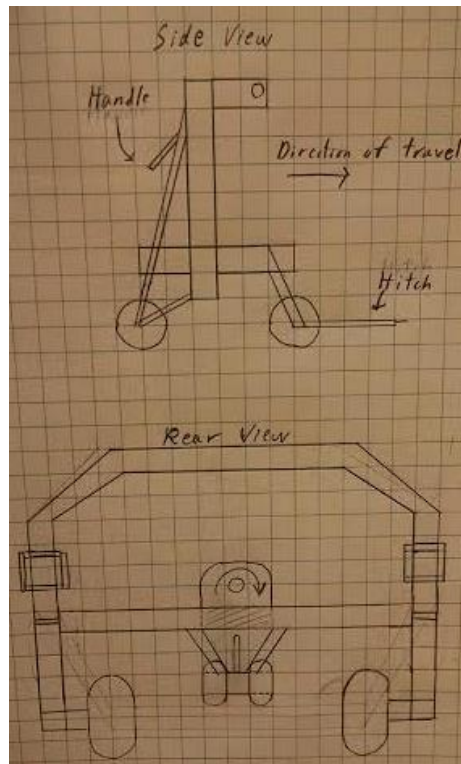

Figure 43-Proposed mounting of wheels

After concepts were generated for transport wheels the majors pros and cons of the system were determined and are displayed in Table 15.

Table 19-Table depicting pros and cons and support systems

| Pros | Cons |
|---|---|
| Moveable without the windrower | Expensive (\$6246) |
| Allows for transport to the field by pickup with implement | Heavy |
| Components are designed to be easily reconfigured by one operator | Lots of moving parts |
| | Header would be dropped in the field |
| | Would need second operator and vehicle |
| | Many points of failure |
| | Short wheel base would not trailer well |
| | Requires drawbar storage on the windrower |

This comparison led to the decision that the superior option would be to not include a transport option on the attachment, but to offer it as an add-on to a deluxe model.

Safety

Safety was of the utmost importance in our design. Both for the manufacturing processes and operating procedures. Most pieces of agricultural equipment are considered inherently dangerous. With this in mind, the overall safety and reducing overall risk for the operator.

PTO Safety

The attachment will feature a 540 PTO shaft. According to farminjuryresource.com, “most PTO accidents occur when the PTO shaft is rotating at slower speeds.” PTO accidents can be caused by a wide range of issues but primarily occur due to some form of operator error. The main risk comes from an operator becoming entangled in either the shaft or directly with the PTO stub shaft. [Farminjuryresource.com](http://farminjuryresource.com) makes it quite clear that “designers and manufacturers of farm machinery have an obligation to make sure their products are as safe as possible.” This means the responsibility of ensuring the attachment is as safe as possible falls on us as the designers.

We must ensure our attachment has a proper PTO master shield. Guidelines for the geometry of a master shield are laid out in ASABE/ISO 500-1 along with the statement that “If the PTO master shield can be used as a step, it shall withstand a vertical static load of 1200 N without permanent deformation.” This load of 1200 N is equivalent to roughly 270 lbf. OSHA regulation 1928.57(b)(1) states that a PTO master shield “shall have sufficient strength to prevent permanent deformation of the shield when a 250 pound operator mounts or dismounts the tractor using the shield as a step.” For design purposes, we will use the values of 1200 N across the top surface of the shield and iterate with various thicknesses to design a proper shield. We constructed a shield model in SolidWorks from ASABE/ISO 500-1 with dimensions and geometry from Table 9 and Figure 13 and iterated the various sheet metal sizes MacDon told us we could use i.e. 7, 11, 14, and 16 gauge steel. Models were fixed along the back of the shield. Fixtures are represented by the green arrows in Figure 43. The 1200 N load was applied across the entire top of the model and is represented by the purple arrows in Figures 43 and 44. The first model to not fail was the one made of 11 gauge A36 steel and produced a factor of safety of 2.77 which meets MacDon’s parameters.

Equation 10-Static factor of safety

$$n = \frac{S_y}{S}$$

Where:

- n = factor of safety
- S_y = yield strength of the material (psi)
- S = stress developed in the member (psi)

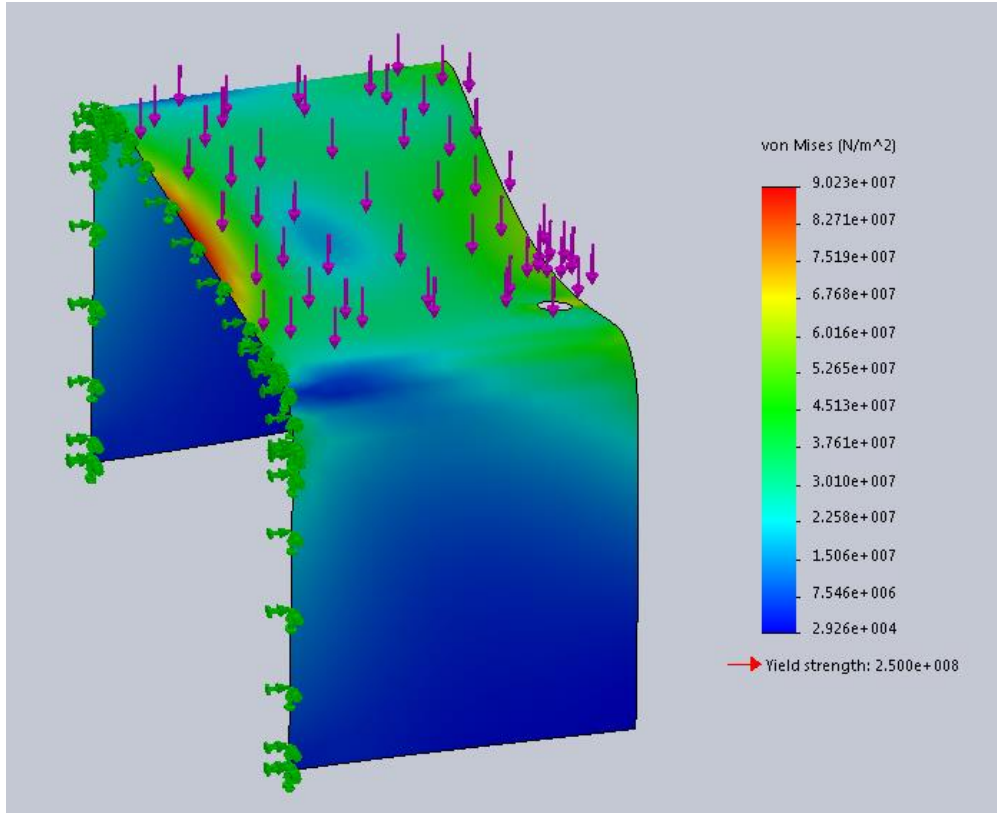

Figure 44-PTO master shield stress simulation with 1200 N load and 11 gauge A36 steel

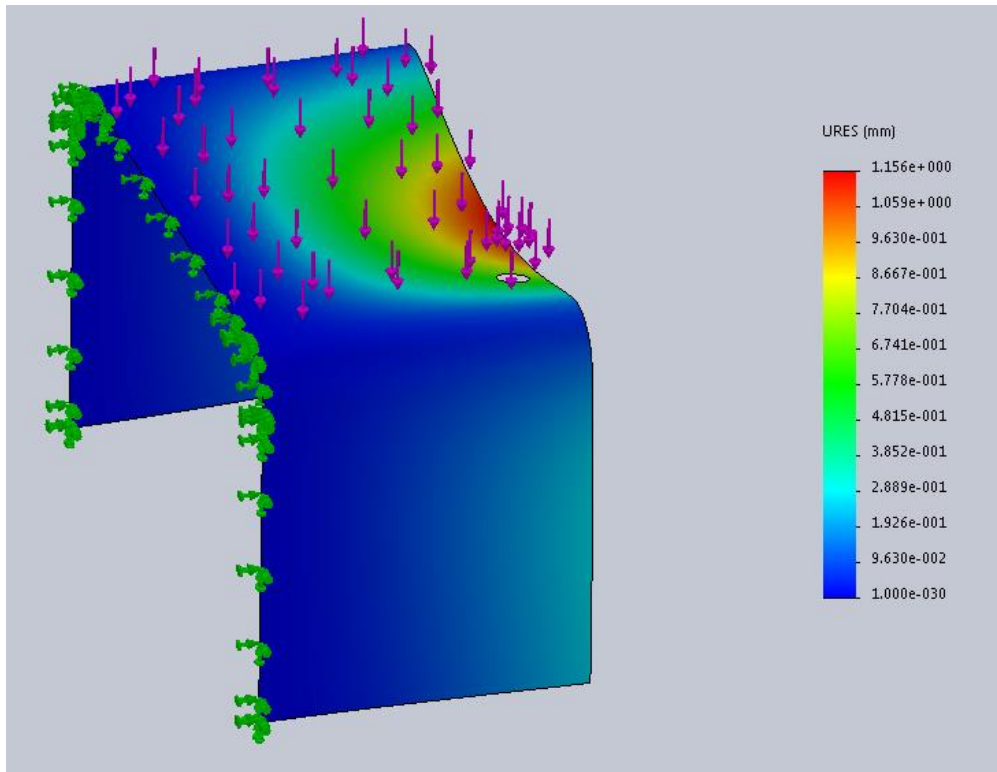

Figure 45-PTO master shield deflection simulation with 1200 N load and 11 gauge A36 steel

OSHA regulation 1928(b)(1)(iii) and (iv) states that “Signs shall be placed at prominent locations on tractors and power take-off driven equipment specifying that power drive system safety shields must be kept in place.” PTO shields are generally able to rotate up away from their downward position to allow for easier connection of an implement to the PTO shaft. A friction hinge will be used to attach the shield to the PTO gear boxes face to allow the shield to be rotated out of the way. Additionally proper safety warning signs or stickers will be placed to ensure that the operator knows that they must return the shield to its down position for operation purposes. Guidelines for proper safety images are outlined in ANSI/ASABE Standard AD11384:1995(April 2011).

Flying Debris Safety

The addition of rock shield may need to be an added option to the attachment as it will allow the windrower to pull PTO powered implements that may throw debris in all directions such as a PTO driven mower. Because the windrower is operating engine forward while using the attachment, what would normally be considered the front windshield is now acting as the rear window. This means there is a large surface area of glass that has the potential of having foreign objects thrown at it by the PTO powered implement. While it should not be necessary to build a rock shield for prototype purposes, this should be addressed by MacDon if they decide to market this product.

Hydraulic Safety

Hydraulic lines contain high pressure fluid that can be detrimental to operators if breaks or pinching occurs in lines. If a leak is found, operators under no circumstances should run any of their appendages over the line to find the leak. A common practice is to use cardboard, or some other material, to shield oneself and to find potential leaks. Proper safety labels should be placed on all lines and around connections on the implement in order to insure operator safety.

Recommendation

Based on the design concepts discussed previously and after comparing the advantages and disadvantages of each option, Missing Link Engineering is proposing to MacDon the following combination of concepts for the further design and construction of a functioning prototype for testing purposes as displayed in Figure 46.

The model is designed around as many preexisting MacDon parts as could be reasonably used i.e. gearbox, hydraulic motor, and hydraulic receivers. It met all standards that could be found to apply to it, and if MacDon believes this is paramount then this configuration of the attachment is primed for testing purposes. The square frame provides strength along with ideal mounting locations for hydraulics, PTO, and drawbar. The drawbar provides two usable positions for the operator. An operator used to operating the windrower with a normal header would have no problem mounting the attachment to the windrower. The openness of the design allows for easy maintenance for an operator and assembly or a manufacturer.

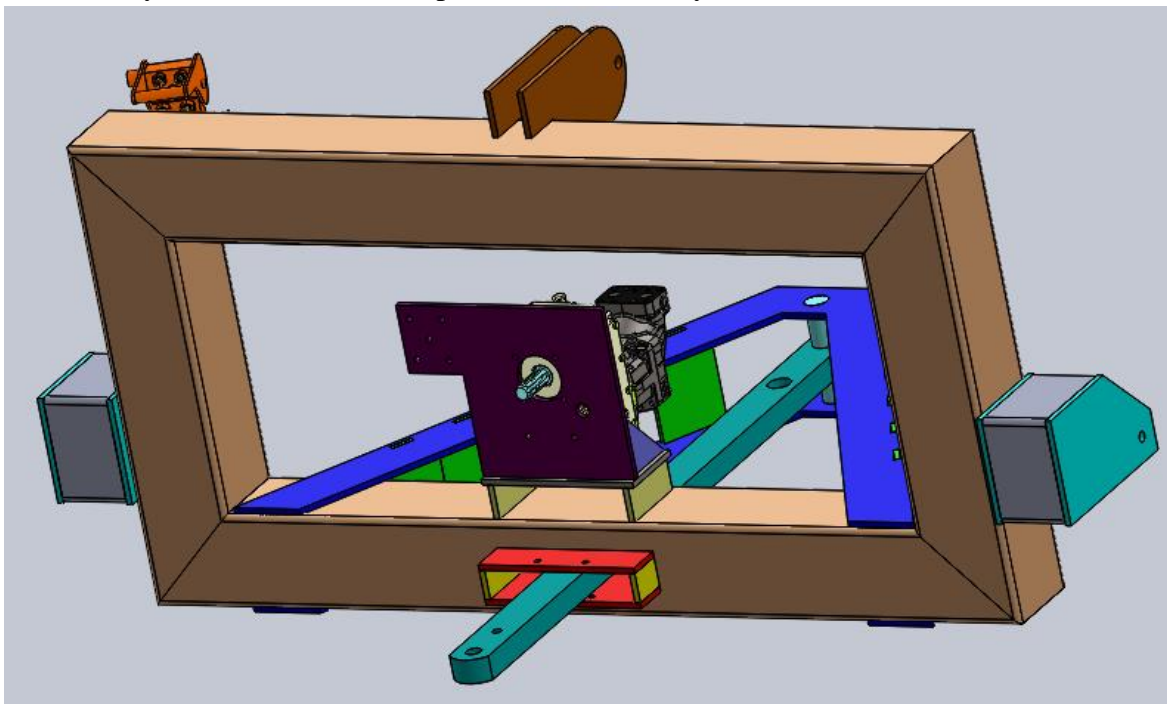

Figure 46-Recommended prototype

Further research into other OEMs revealed that they do not follow exact ASABE standards in the construction of their drawbars. John Deere and Massey Ferguson use what would be classified as a category 1 drawbar in their 100 to 150 HP range tractors. These drawbars are also shorter than the drawbar used in the recommended design, Figure 46. The retail price of these is also comparable or less than the prospective price of drawbar material in Table 19. Using a shorter drawbar would reduce the amount of plate needed for the project and decrease cost. This option can be further explored if MacDon decides they would be ok with sourcing a component from another OEM.

Proposed Prototype Budget

Table 20: Prototype budget breakdown

| Component | Source | Qty | Cost |
|---|--------------------------|--------|-------------|
| Frame and Drawbar | | | |
| 8"x8"x.25" Square tubing (24' stock) A500 | metalsdepot.com | 1 | \$ 670.00 |
| .5" Plate (4'x8' sheet) A36 | metalsdepot.com | 2 | \$ 800.00 |
| Drawbar (2"x3.5" stock 72") 1018 | Stillwater Steel | 1 | \$ 450.00 |
| 2" Drawbar pin (1' stock) A36 | metalsdepot.com | 1 | \$ 20.00 |
| PTO | | | |
| Gearbox | Comer (MacDon) | 1 | \$ 684.00 |
| Hydraulic Motor & hoses | MacDon (Parker-Hannifin) | 1 | \$ 1,437.00 |
| Hydraulic Receiver Plate | MacDon | 1 | \$ 100.00 |
| Shield Material (11 gauge 1'x4' sheet) | metalsdepot.com | 1 | \$ 25.00 |
| Shield Hinge | McMaster-Carr | 1 | \$ 20.00 |
| Auxiliary Hydraulics | | | |
| Hoses/Fittings | Misc. | X | \$ 200.00 |
| Hydraulic Receiver Block | MacDon | 1 | \$ 980.00 |
| Pioneer outlets | McMaster-Carr | 5 | \$ 100.00 |
| Dust Covers | McMaster-Carr | 5 | \$ 20.00 |
| Shop/Manufacturing | | | |
| Cutting/Welding/Etc (\$20/hr) | Biosystems Shop | 20 hrs | \$ 400.00 |
| Misc. Hardware | | | |
| Nuts/Bolts | Misc. | X | \$ 20.00 |
| Total | | | \$ 5,926.00 |

Project Schedule

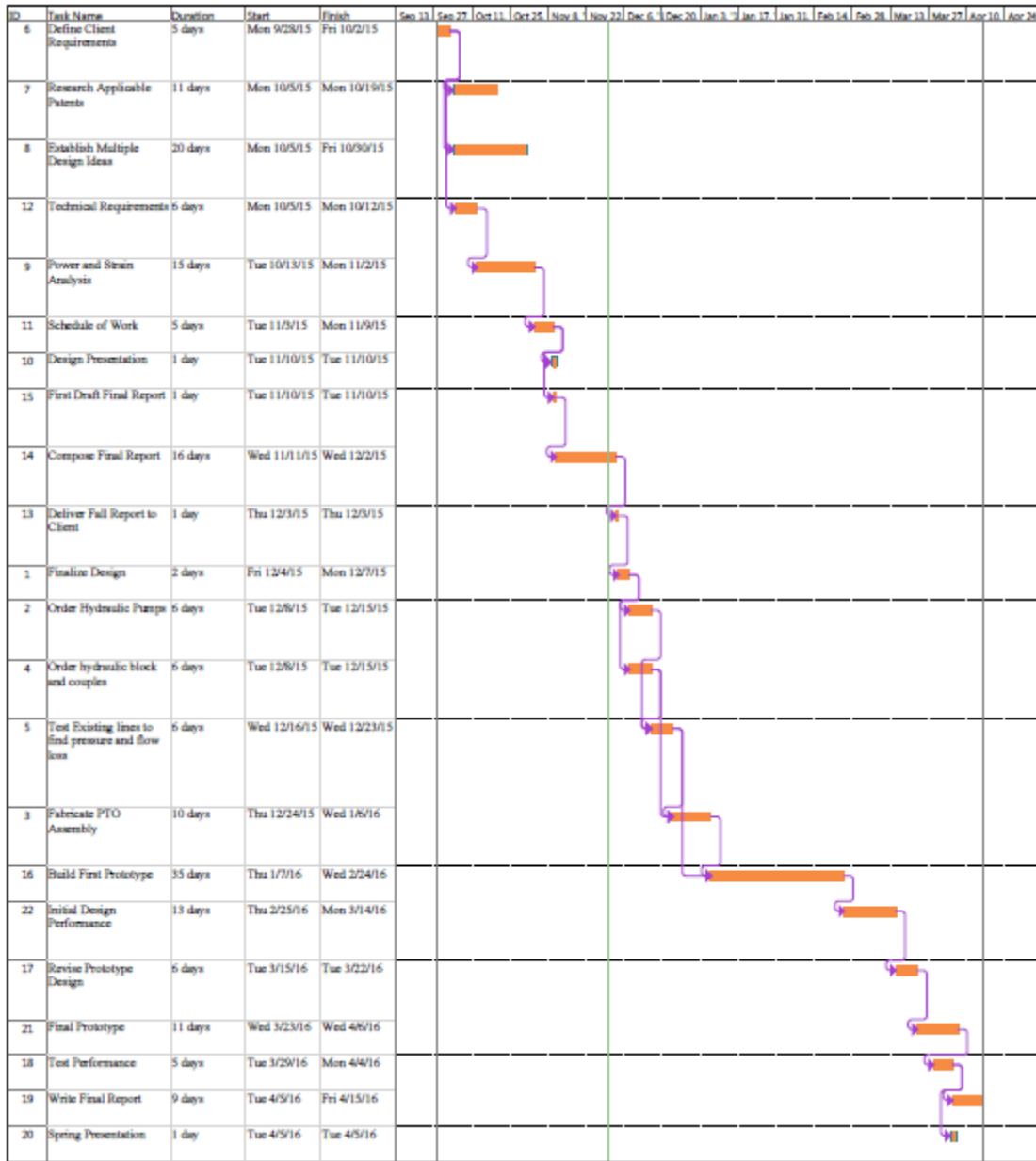

Figure 47-Project Gantt chart

References

Dunn, J.T., et al. 2007. Tractor with reversible operator position for operation and transport, U.S. Patent No. 7159687B2

Fadden, D. K., and Fosco, L.D. 1970. Tractor quick hitch attachment, U.S. Patent No. 3531140A

Honey, G. J. 1991. Swather attachment for bi-directional tractor, U.S. Patent No. 5031394A

Degelman, W. J. 2000. Multi-functional self-propelled farm tractor, U.S. Patent No. 6160643B1

Paumier, J. 2002, Vertical underground stump grinding apparatus, U.S. Patent No. 20040098885A1

ANSI/ASABE Standard AD6489-3:2004, July 2004, "Agricultural vehicles-Mechanical connections between towed and towing vehicles-Part 3: Tractor drawbar," www.asabe.org

ANSI/ASABE Standard AD11384:1995 (April 2011), May 2011, "Tractors, machinery for agricultural and forestry, powered lawn and garden equipment – Safety signs and hazard pictorials – General principles," www.asabe.org

ASABE/ISO 500-1:2014, Feb 2015, "Agricultural tractors — Rear-mounted power take-off types 1, 2, 3 and 4 - Part 1: General specifications, safety requirements, dimensions for master shield and clearance zone," www.asabe.org

ASABE/ISO 500-3:2014, Feb 2015, "Agricultural tractors – Rear-mounted power take-off types 1, 2, 3, and 4 - Part 3: Main PTO dimensions and spline dimensions, location of PTO," www.asabe.org

ANSI/ASAE S366.2, May 2004, "Agricultural tractors and machinery – General purpose quick-action hydraulic couples," ISO 5675:1992, www.asabe.org

Occupational Safety & Health Administration [OSHA]. 1976. Regulations (Standard – 29 CFR).1928. Retrieved from http://www.osha.gov/pls/oshaweb/owadisp.show_document?p_table=STANDARDS&p_id=10958

"Farm Injury Resource Center." *Farm Injury Resource Center*. N.p., n.d. Web. 29 Nov. 2015.

MacDon. (2012). *M155 Self-Propelled Windrower: Operator's Manual*. Winnepeg, CA

MacDon. (2012). *D65 Harvest Header For Self-Propelled Windrowers: Operator's Manual*. Winnepeg, CA

Budynas, R. G., Nisbett, J. K., (2015). *Shigley's Mechanical Engineering Design* (10th ed.). New York, NY: McGraw-Hill Education

Sriastava, A. K., et al., (2012). *Engineering Principles of Agricultural Machines* (2nd ed.). ASABE

www.engineeringtoolbox.com



Missing Link Engineering

MacDon[®]

Fall Report

12/4/2015

The Team



Adam

Seth

Carson

Andrew



1. MacDon Background
2. Project Definition
3. Research
4. Structure
5. Hydraulics
6. Transport Option
7. Budget
8. Recommendation



- Winnipeg, MB
- OEM Company
 - Windrowers
 - Combine Headers



All pictures from provided by MacDon Industries Ltd.



MacDon Industries Ltd.

Global Presence

Industry
Preferred

All Colors





- Small farmers need multipurpose equipment
- Windrowers have one very specific purpose
- Tractors and windrowers are expensive
- MacDon's Dual Direction technology provides a potential solution



The goal of this project is to create an innovative, cost-efficient and reliable attachment to allow a MacDon M155 Self-Propelled windrower to pull various non-tillage implements.





- Easily attach to windrower
- Hydraulically driven PTO
- Swinging drawbar
- Multiple Pioneer quick couplers
- Pull non-tillage equipment only





- Manufacturing cost of \$3500 and MSRP \$5000
- Utilize MacDon's current parts catalog
- Design in metric
- Static factor of safety of 2
- Dynamic factor of safety of 4





- Use existing hydraulic power
- Meet ASABE/ISO/OSHA standards
- Weight cannot exceed 3734 lbf



https://www.deere.com/common/media/images/product/equipment/hay_and_forage/9_series_round_balers/559/r4a020901_559megawide_642x462.png



http://www.ssbtractor.com/hay_rakes.jpg

- Patent search
- ASABE and industry standards
- Equipment requirements
- Industry competition



http://www.rustsales.com/wp-content/uploads/catablog/originals/IMG_4331.JPG



<http://www.haroldsequipment.com/media/images/equipment/trailer-lagoon-pump-geahoule-22885.jpg>



- New Idea® Uniharvester
- Quick hitch
- Self-propelled sprayer conversion
- Tractor to windrower conversion



- Multifunction tool created by New Idea®



http://www.redpowermagazine.com/forums/uploads/monthly_01_2013/post-72-0-17408100-1358875369.jpg



- Quick hitch attachment for three point connection

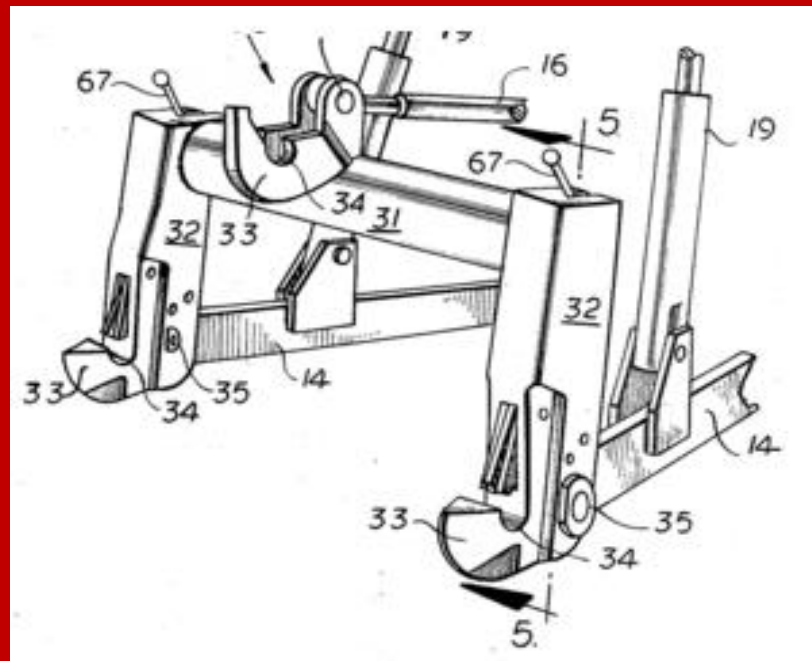

U.S. Patent 3531140A

- Conversion from sprayer to windrower

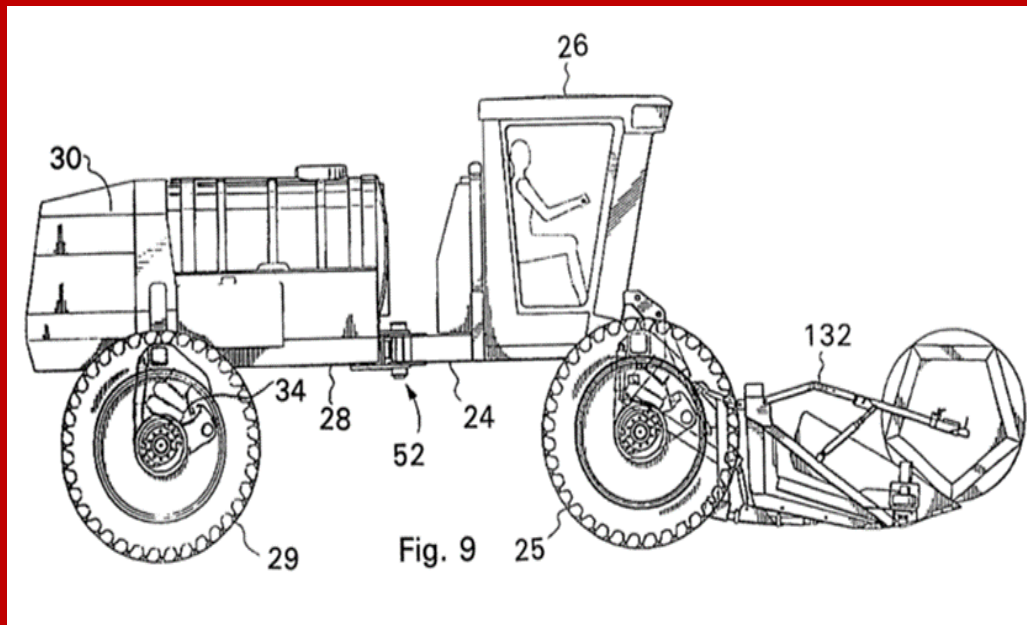



- Attachment to articulating tractor for windrower conversion

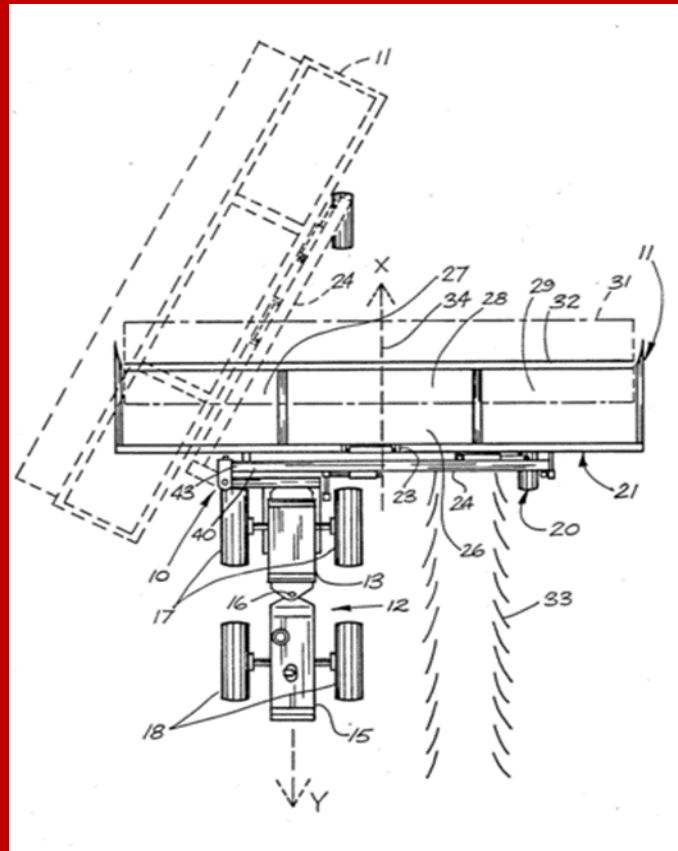



- 38 balers compiled across 4 brands
- Balers larger than 100hp omitted
- Minimum 70HP

| Baler Analysis | |
|-----------------------------|-------|
| Number of brands | 4 |
| Number of balers | 38 |
| Most common HP | 70 |
| Average HP | 61 |
| 540 PTO option | 34 |
| 1000 PTO option | 15 |
| Max Drawbar Weight (N)* | 7829 |
| Max Drawbar Draft (N)** | 14354 |
| *Massey Ferguson 2946/2946A | |
| **Vermeer 604 Super M | |



- Assumed to pull in low range (0-11 MPH)
- Inputs taken directly from M155 Tech Manual
- Used to determine drawbar class of 2

| Power to Wheels Calculations | | | | | | |
|------------------------------|---------|---------|-----------|-----------|-------------|--------|
| V_m (in ³ /rev) | Q (gpm) | P (psi) | T (lb*in) | T (lb*ft) | n_m (rpm) | P (HP) |
| 4.15 | 40 | 5500 | 3633 | 303 | 2227 | 128 |

$$T = \frac{\Delta P * V_m}{2\pi}$$

$$n_m = \frac{Q}{V_m}$$

$$P = \frac{T * n_m}{5252}$$

- ANSI/ASABE Standards Used
- AD6489-3 for drawbar category and design
- AD6489-4 for drawbar category and design

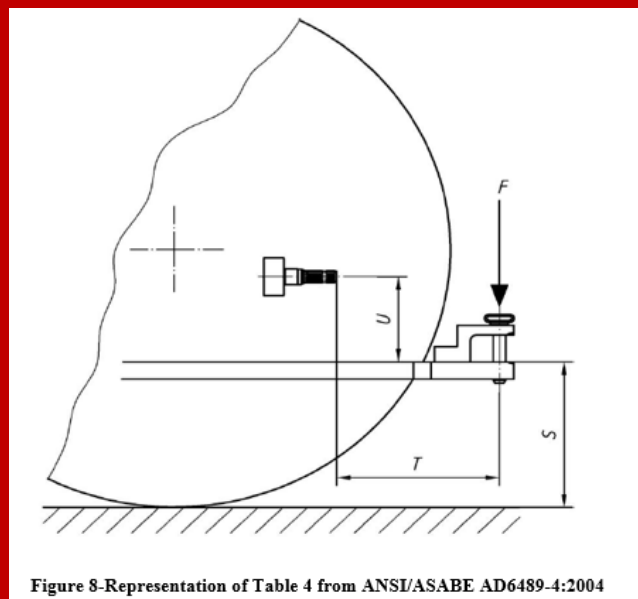

a) clevis removed from the drawbar

Figure 11-Representation of Table 7 from ANSI/ASABE AD6489-4:2004

- Main frame
- Drawbar mounting
- Three point connection
- Gearbox mounting

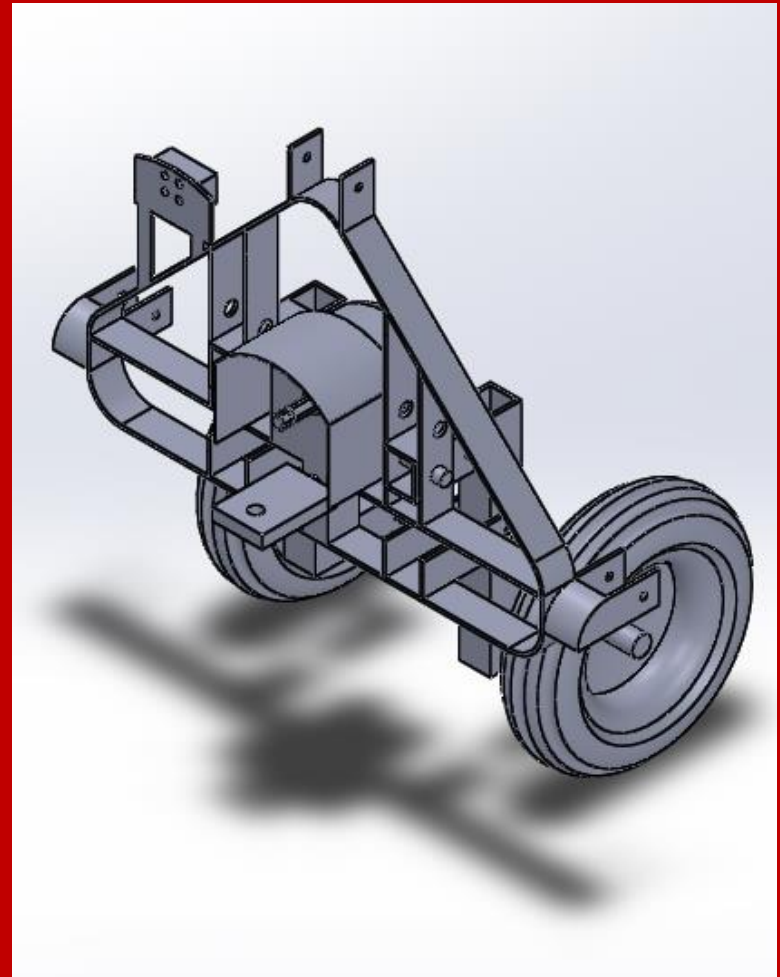

- Made from 6 pieces
- Alternative loading
- Potentially better stress flow
- Higher manufacturing costs

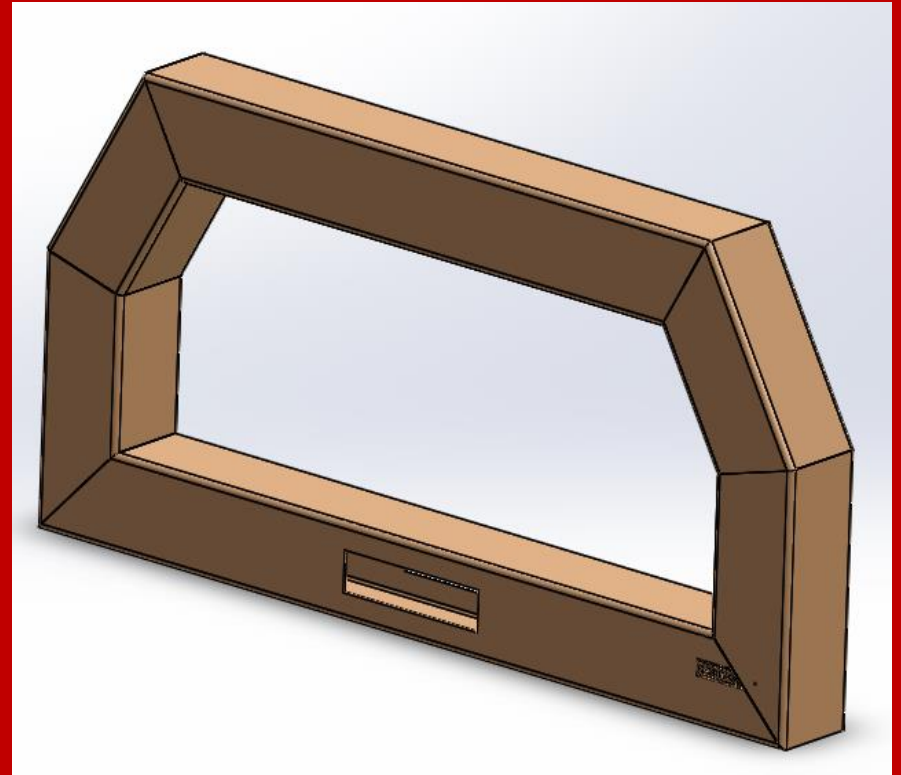



- Square Frame
- More space within frame for mountings
- Better manufacturability
- Better hydraulic mounting locations

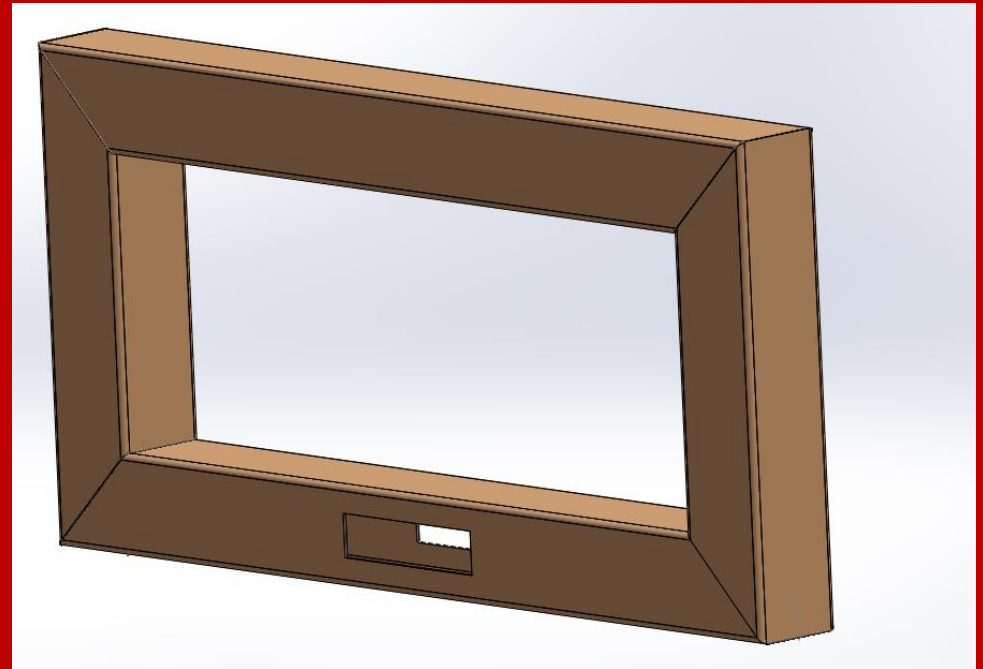

- Reinforces structural integrity
- Allows for swinging positions
- Potential safety chain location

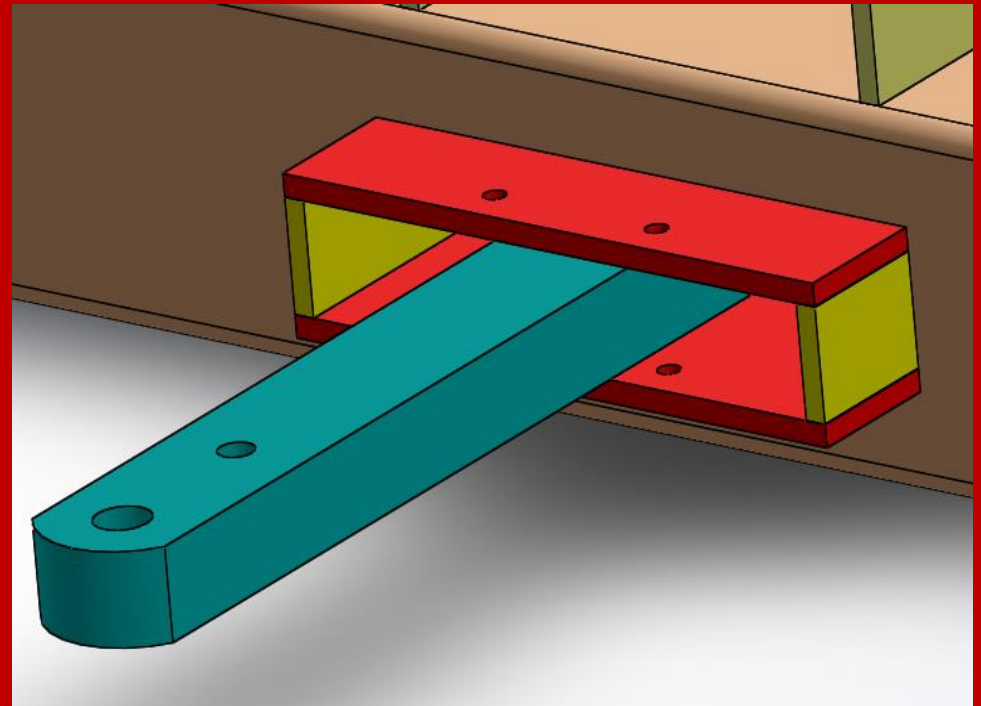

- Square tubing mounting
- Small size
- Low factor of safety

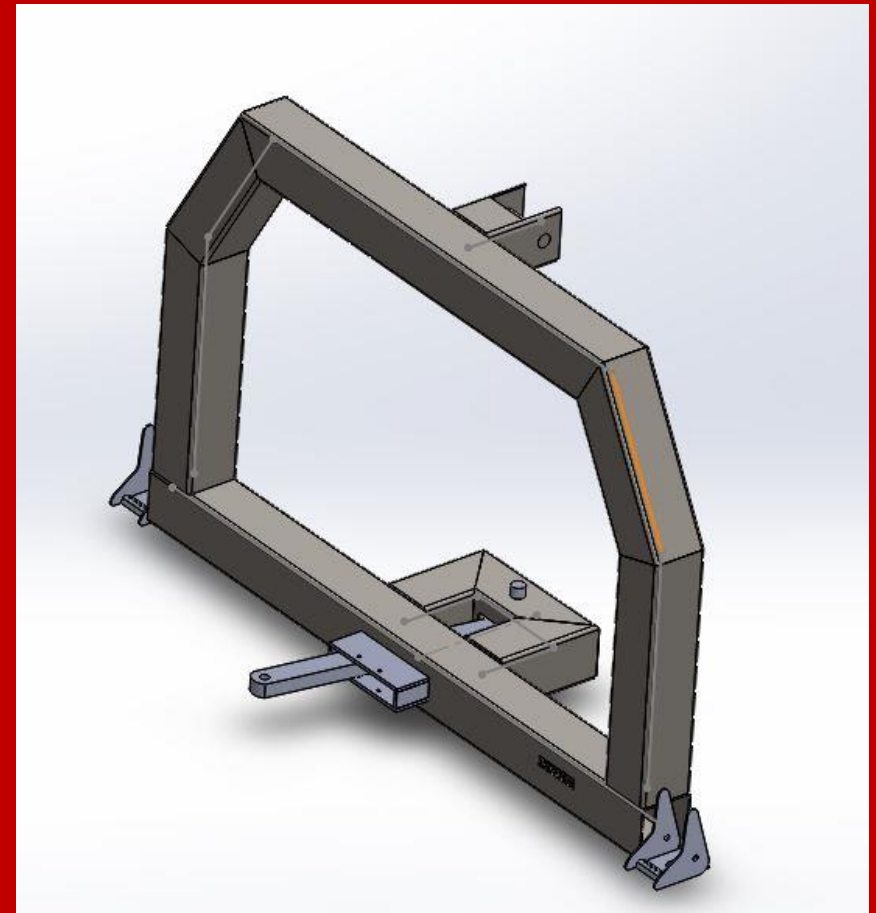

- Square tubing mounting (dark red)
- No slots cut in tubing
- Lower fabrication cost

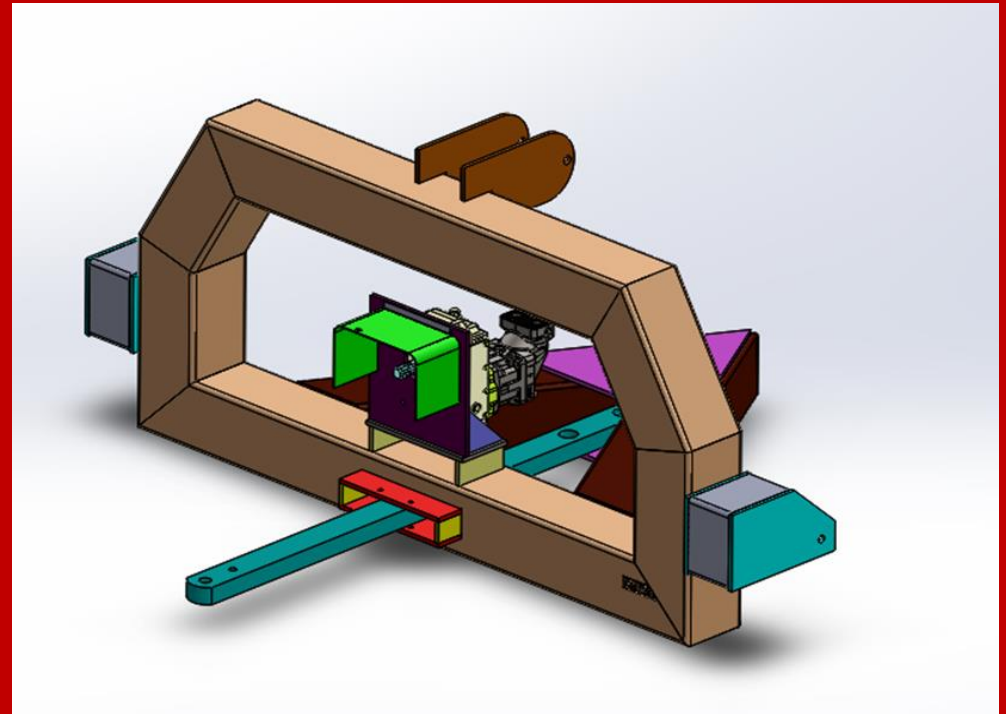

- Square tubing mounting (dark red)
- Higher Weight
- Drawbar interference issues

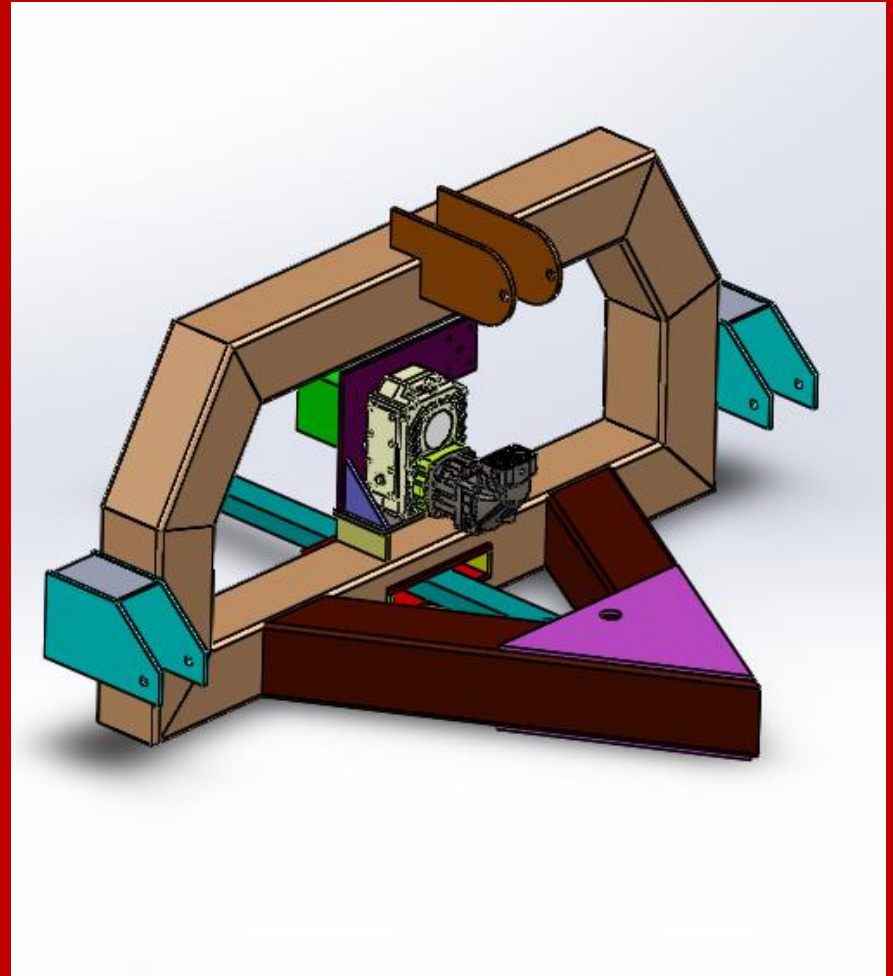

- Plate mounting (1/2") (navy blue)
- Lower material costs
- Longer welded surface

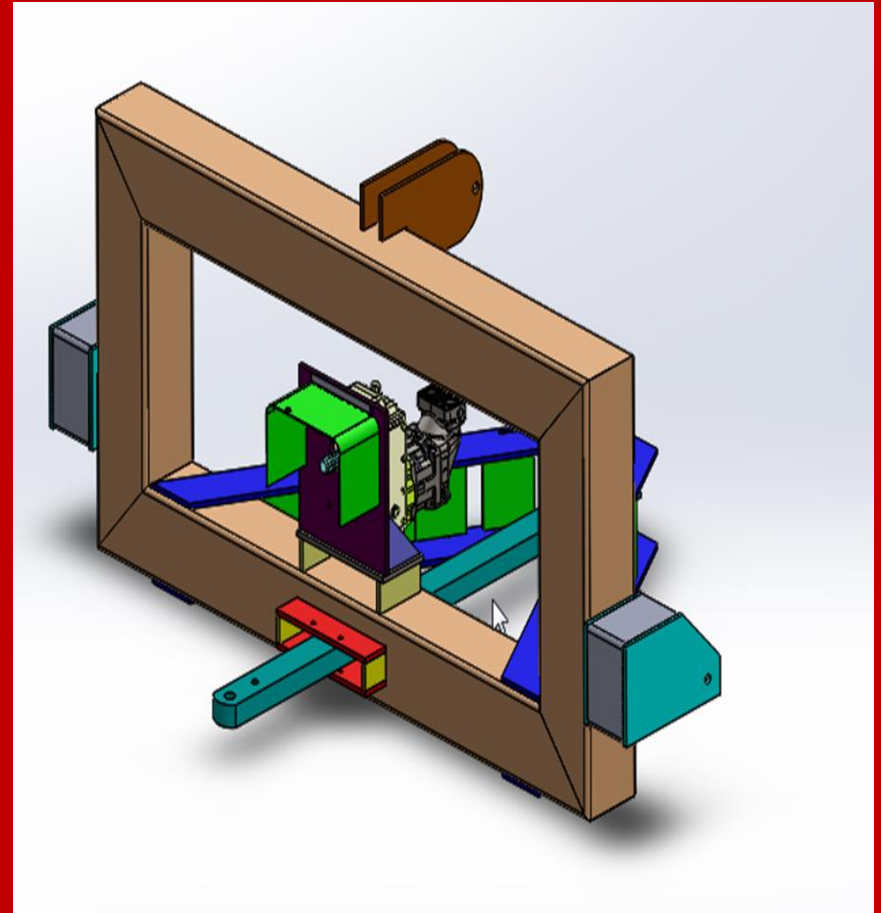

- Inner plate supports (1/2") (green)
- Slot and tab design
- Lower Weight

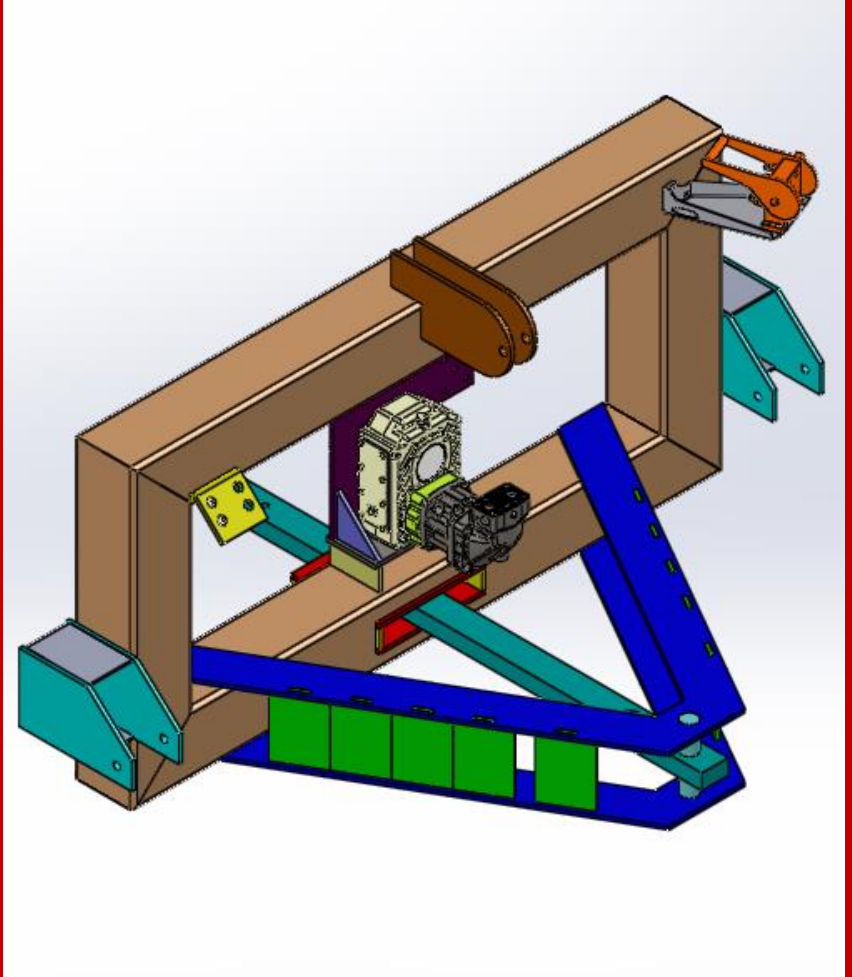

- Mounting analysis of factor of safety
- Analysis on bending shear
- ASME elliptic factor of safety

| Mounting Type | n_f |
|------------------------------------|-------|
| Square Tubing, square mount | 2.43 |
| Square Tubing, triangular mount | 9.04 |
| Flat plate, triangular mounting | 9.04 |

$$\left(\frac{\sigma_a}{S_e}\right)^2 + \left(\frac{\sigma_m}{S_y}\right)^2 = \frac{1}{n_f^2}$$

$$S_e = S_e' k_a k_b k_c k_d k_e k_f$$

- Bottom boots fit directly over windrower legs (light blue)
- Bottom boots fit directly over windrower legs (light blue)
- Top connection pin (brown)
- Side connections 12" off the ground

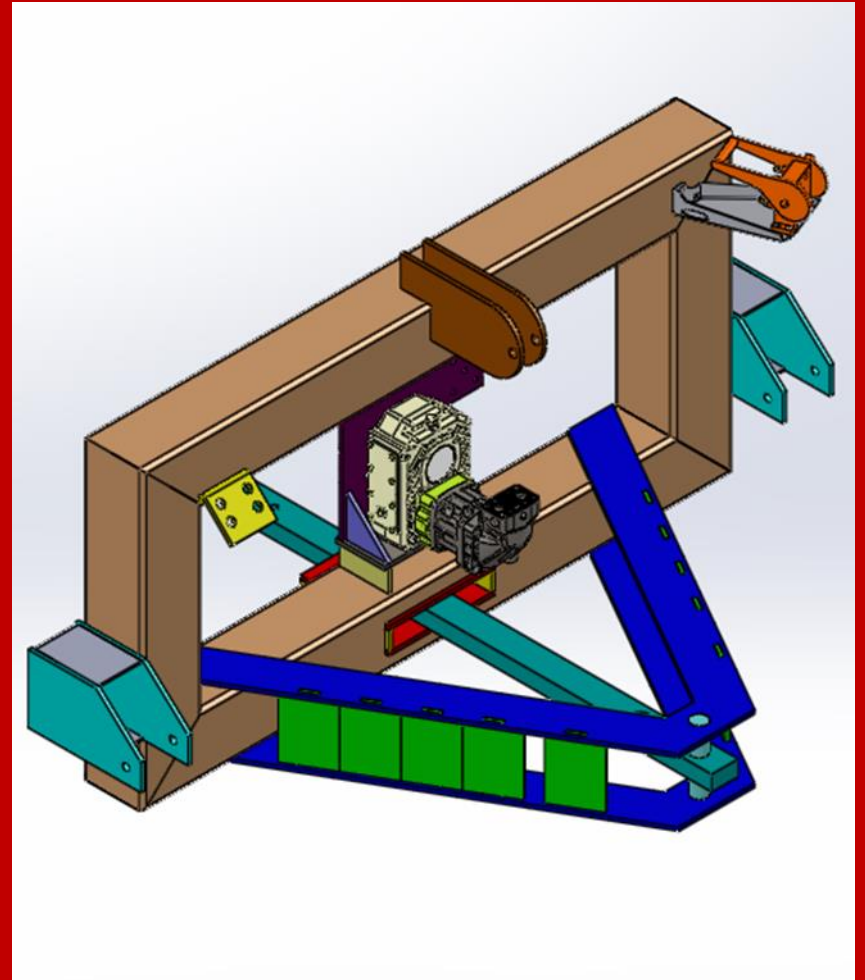



- Top connection allows for use of existing float drive
- Top link operated at 40 degrees below horizontal
- Similar mounting to other MacDon headers





- Use existing hydraulic circuit (i.e. reel, draper, knife)
- Five pioneer standard outlets (right side)
- Easy hookup for operator
- Minimize pinch points for safety

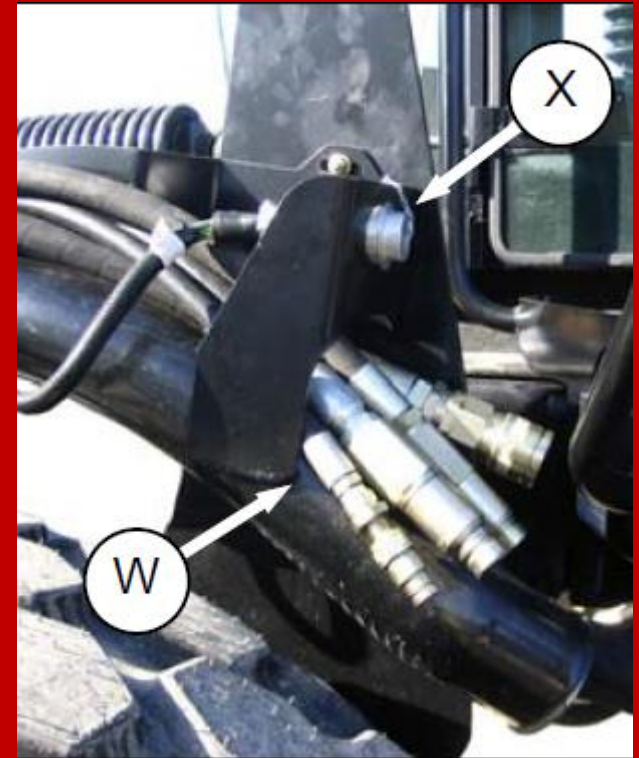

M155 Tech Manual

- Engine forward, low range, brakes disengaged (operation mode)

Traction Drive: Engine Forward, Low Range, Reverse, Brakes Disengaged, Header Not Engaged

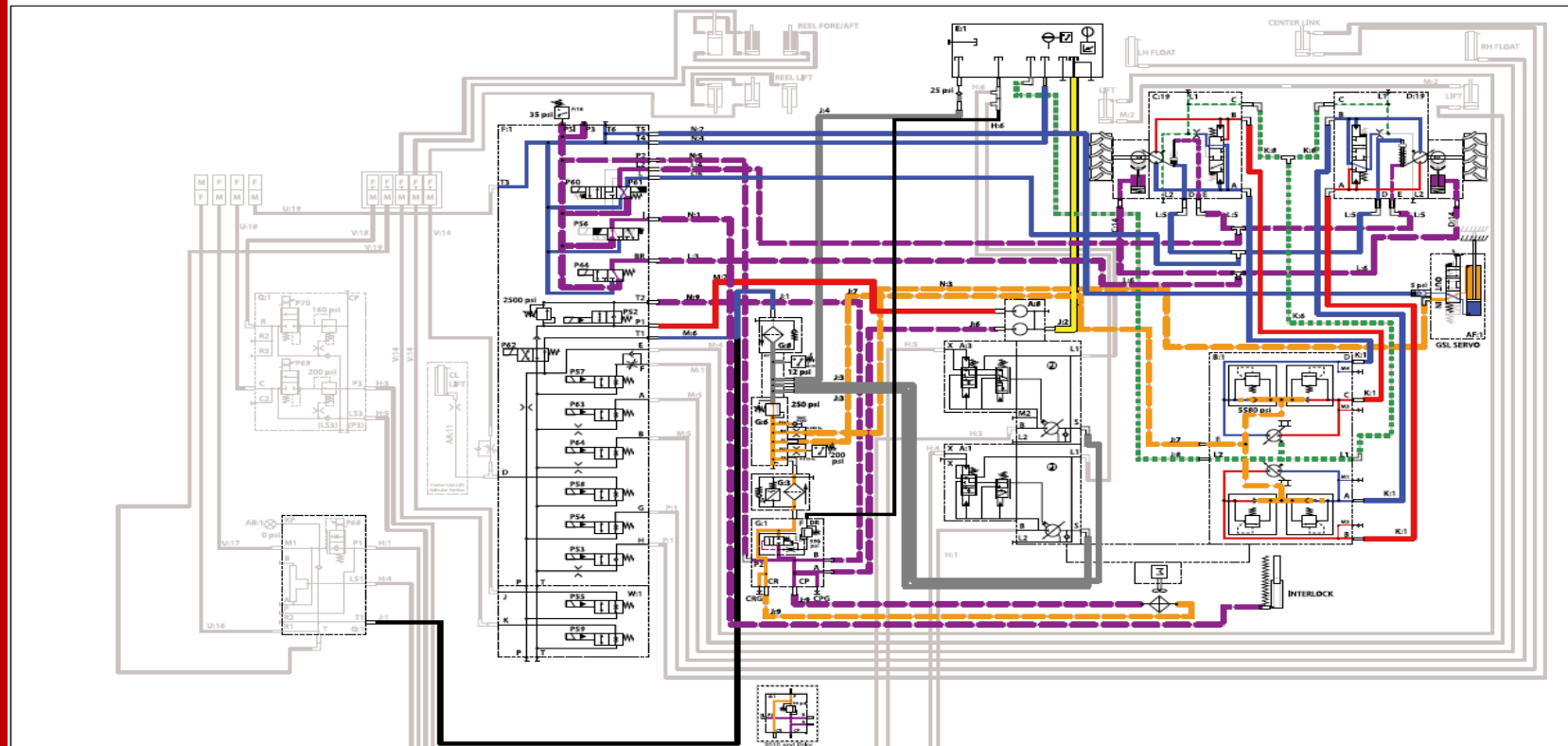



- Draper and reel pressure changed to 4300
- Assumption of 25% loss in fluid to mechanical power

| Hydraulic Power | | | |
|------------------|----------------|--------------------|------------|
| Pump | Flowrate (gpm) | Pressure (psi) | HP |
| Knife | 26 | 4300 | 65 |
| Reel | 13 | 4300 | 33 |
| Draper | 13 | 4300 | 33 |
| | | Theoretical | 130 |
| Assumed Loss 25% | | Predicted | 98 |

$$HP = \frac{Q * P}{1714}$$



- Comer A-640A
- 540 PTO
- Attached PTO Shield and Mounting
- Gear ratio of 1:2-3.8



- Ease of assembly
- Strengthened to support PTO shield
- Ease of access to port

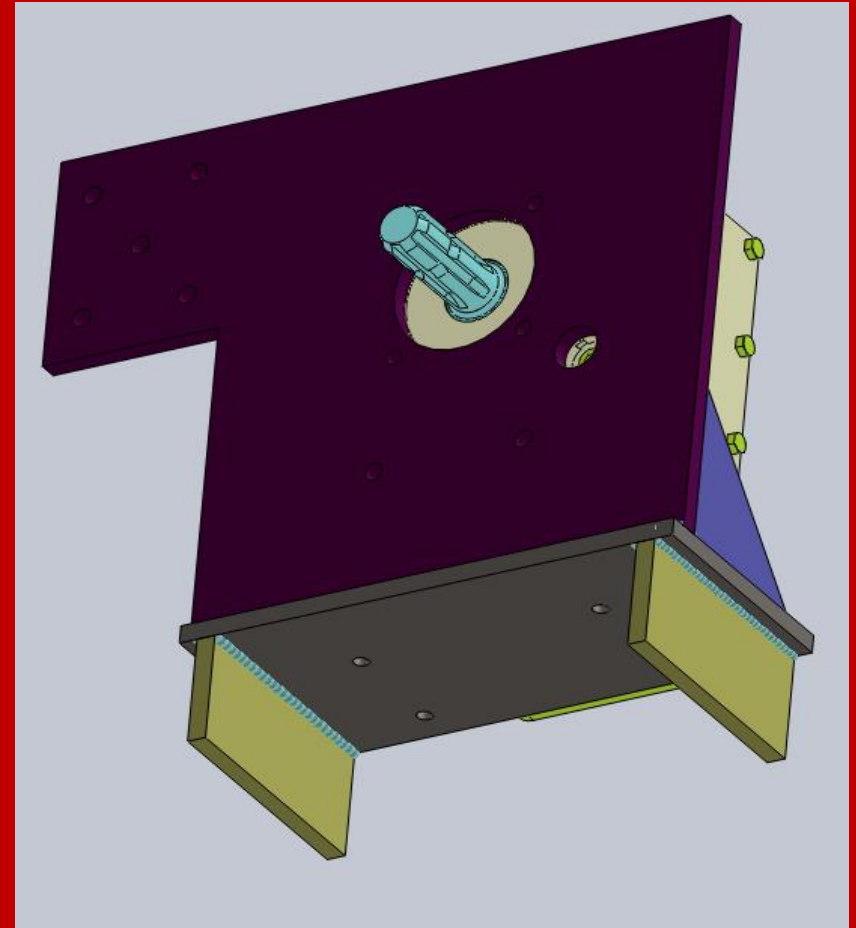

- Parker Hannifin F12 Series
80cc/rev

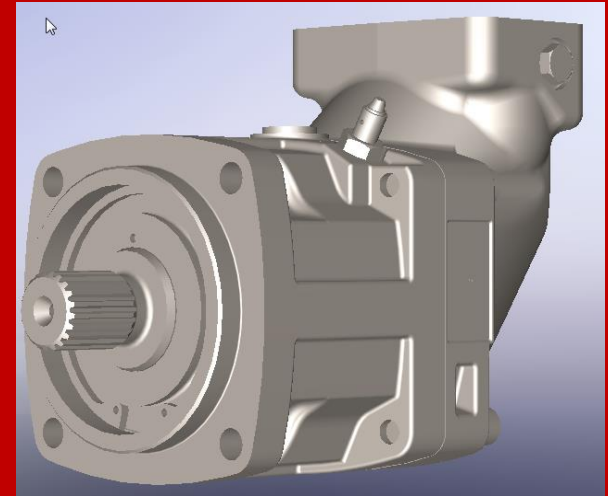

- Bosch RexRoth A2FM28





- Gearbox allows for design torque with lower flowrate charge

| Output Power | Pressure | Flowrate | Speed Shaft (rpm) | Gear Ratio | Displacement (cc/rev) |
|--------------|----------|----------|-------------------|------------|-----------------------|
| 70 | 4300 | 27.90 | 1320.27 | 2 | 80 |

- Multiple connections to Pioneer quick couplers will be used
- The right side of the windrower will have five outlets (2 dual acting and 1 single acting)

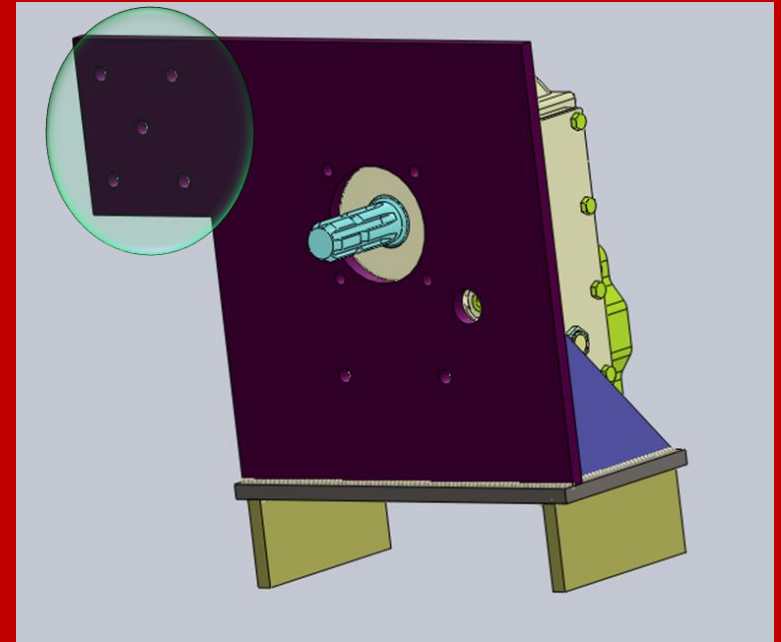

D-series quick connections

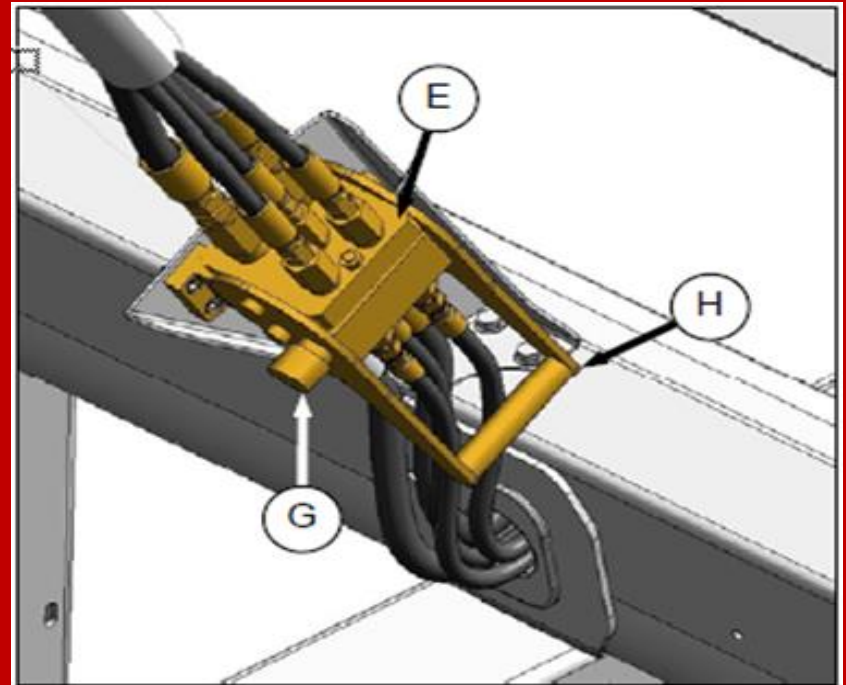
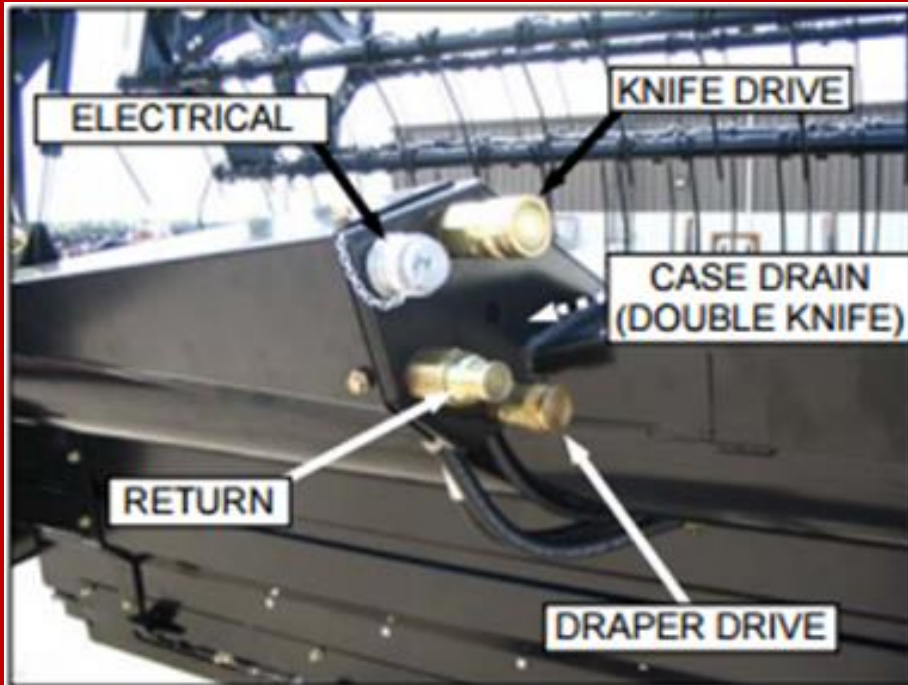

- Allows Attachment to be pulled to and from field via pickup
- Removes retrieval factor on implement from field to storage

6.3.6.3 Engine-Forward Operation



ENGINE-FORWARD - SEAT FACES ENGINE
DIRECTION OF TRAVEL



- Removable hitch for transport mode

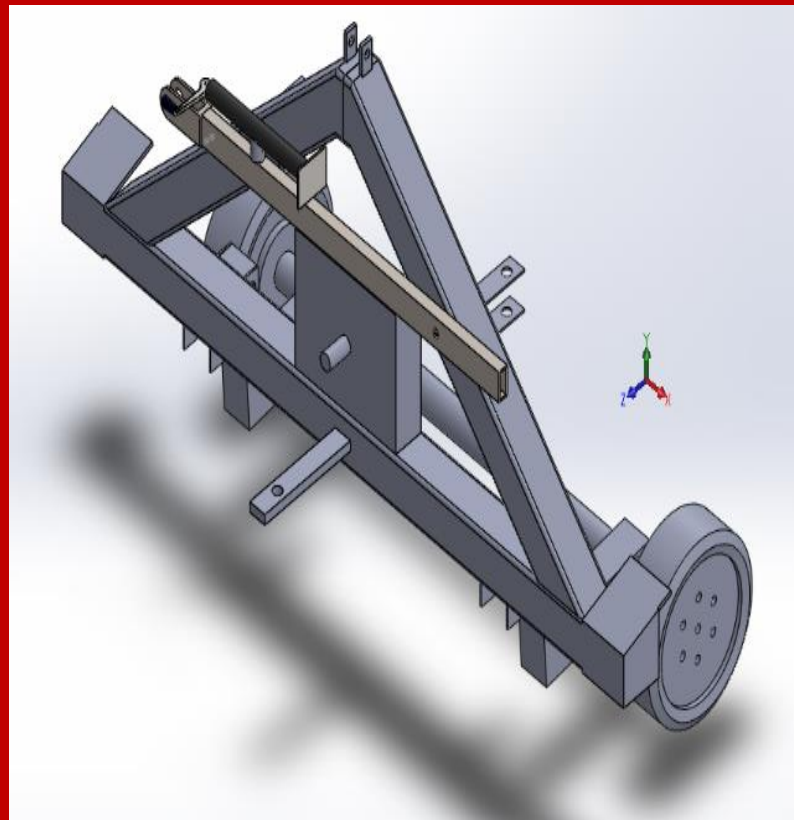

- Attached wheel and transport/field mode orientation

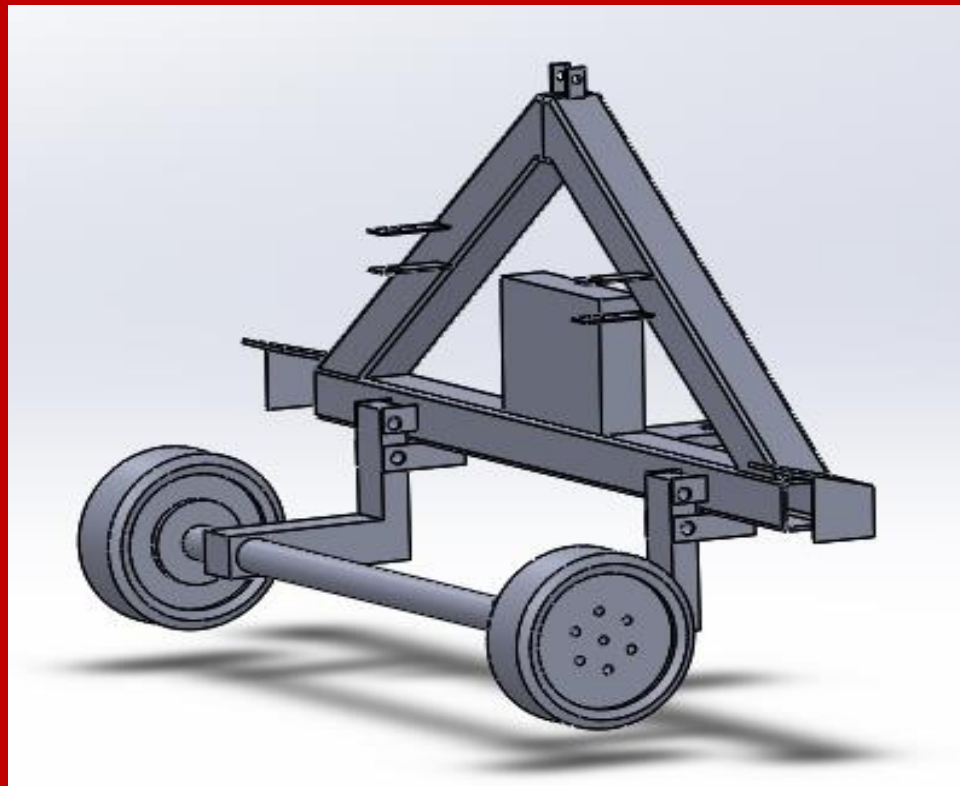



Front caster from D65

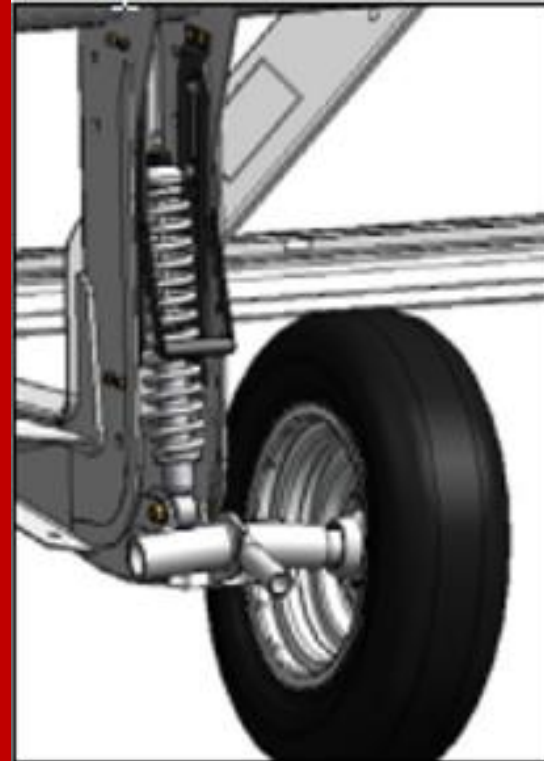

Stabilizer Wheel from D65



- Transport mode added benefit displayed below
- Cons heavily outweigh the pros

Transport Wheels

| | | | | | | | | |
|-------------|--|--|--|--------------------------------------|-----------|------------------------|-------|-------------------|
| Pros | Moveable without the windrower | Allows for transport to the field by pickup with implement | Components are designed to be reconfigured by one operator | | | | | |
| Cons | Would need second operator and vehicle | Short wheel base would not trailer well | Requires drawbar storage on the windrower | Header would be dropped in the field | Expensive | Many points of failure | Heavy | Many moving parts |



- D65 wheel assemblies cost >\$6000
- Fabrication Cost 5hr @\$20/hr \$100
- Jack kit \$120

| Description | Cost |
|--------------------|---------------|
| D65 Wheel Assembly | \$6340 |
| Labor | \$100 |
| Jack kit | \$120 |
| Total Cost | \$6560 |



- Budgetary Constraints limit transport mode
- Potential for a deluxe model or wheel kit
- Create alternative wheel set

- PTO Shield
- Addition of a rock shield
- Signs and Warnings
- Lift lockout needed

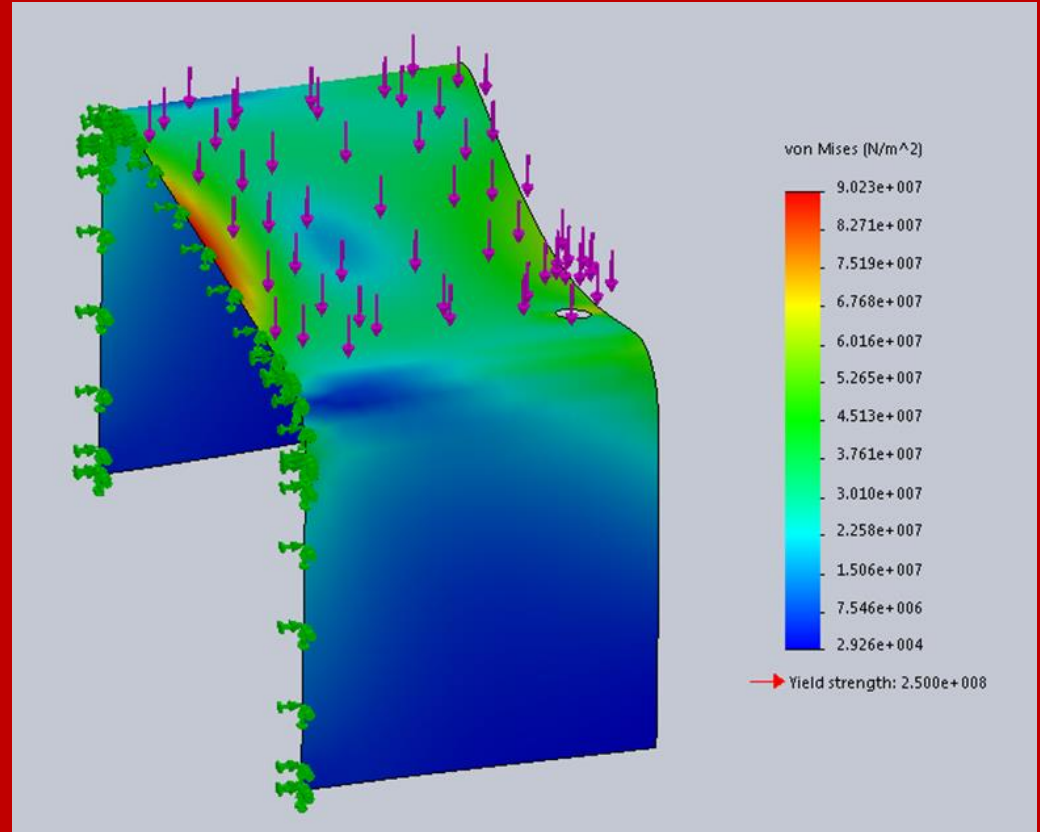



| Component | Source | Qty | Cost |
|--|--------------------------|------------|-------------|
| Frame and Drawbar | | | |
| 8"x8"x.25" Square tubing (24') A500C | metalsdepot.com | 1 | \$ 670.00 |
| .5" Plate (4'x8' sheet) A36 | metalsdepot.com | 2 | \$ 800.00 |
| Drawbar (2"x3.5" stock 72") 1018 | Stillwater Steel | 1 | \$ 450.00 |
| 2" Drawbar pin (1' stock) A36 | metalsdepot.com | 1 | \$ 20.00 |
| PTO | | | |
| Gearbox | Comer (MacDon) | 1 | \$ 684.00 |
| Hydraulic Motor & hoses | MacDon (Parker-Hannifin) | 1 | \$ 1,437.00 |
| Hydraulic Receiver Plate | MacDon | 1 | \$ 100.00 |
| Shield Material (11 gauge 1'x4' sheet) | metalsdepot.com | 1 | \$ 25.00 |
| Shield Hinge | McMaster-Carr | 1 | \$ 20.00 |



Auxiliary Hydraulics

| | | | |
|--------------------------|---------------|---|-----------|
| Hoses/Fittings | Misc. | X | \$ 200.00 |
| Hydraulic Receiver Block | MacDon | 1 | \$ 980.00 |
| Pioneer outlets | McMaster-Carr | 5 | \$ 100.00 |
| Dust Covers | McMaster-Carr | 5 | \$ 20.00 |

Shop/Manufacturing

| | | | |
|-------------------------------|-----------------|--------|-----------|
| Cutting/Welding/Etc (\$20/hr) | Biosystems Shop | 20 hrs | \$ 400.00 |
|-------------------------------|-----------------|--------|-----------|

Misc. Hardware

| | | | |
|------------|-------|---|--------------------------|
| Nuts/Bolts | Misc. | X | \$ 104.00 |
| | | | Total \$ 6,000.00 |

The Mule

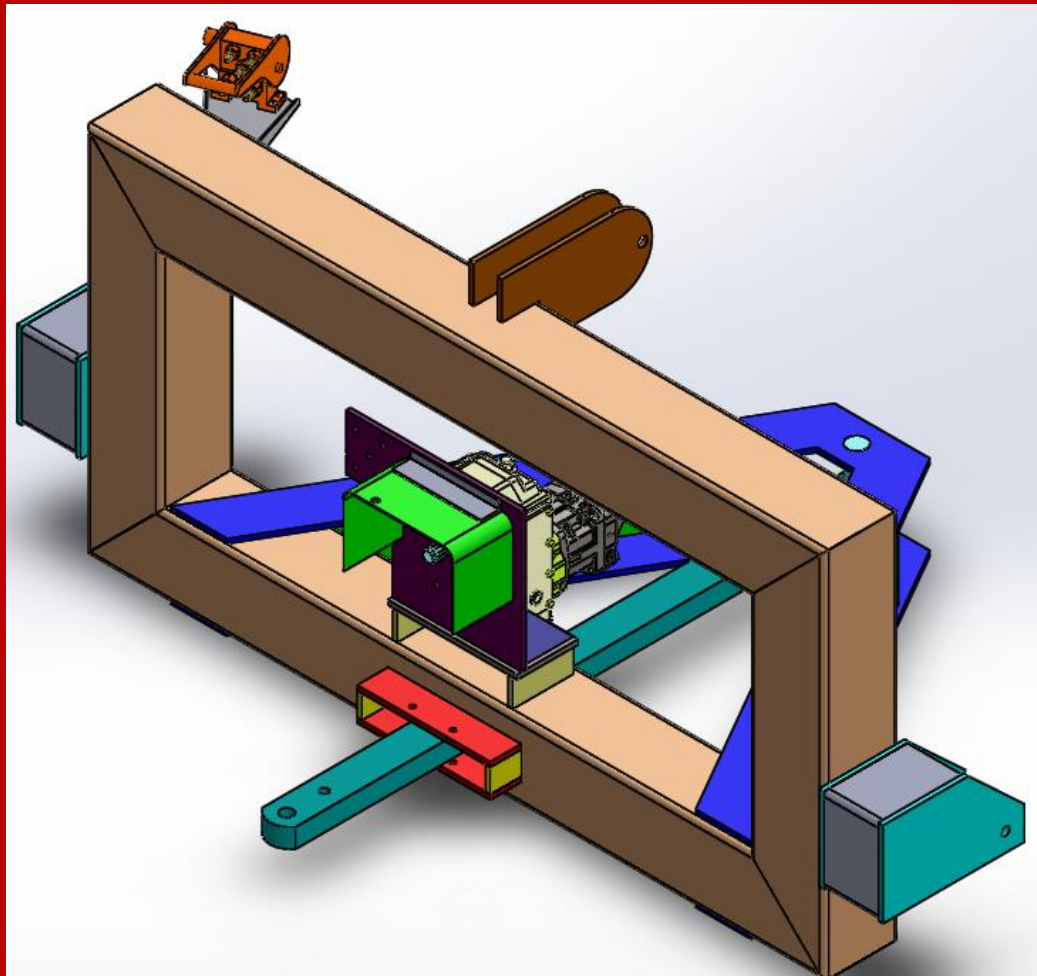



| Task Name | Duration | Start | Finish |
|--|----------|--------------|--------------|
| Define Client Requirements | 5 days | Mon 9/28/15 | Fri 10/2/15 |
| Research Applicable Patents | 11 days | Mon 10/5/15 | Mon 10/19/15 |
| Establish Multiple Design Ideas | 20 days | Mon 10/5/15 | Fri 10/30/15 |
| Technical Requirements | 6 days | Mon 10/5/15 | Mon 10/12/15 |
| Power and Strain Analysis | 15 days | Tue 10/13/15 | Mon 11/2/15 |
| Schedule of Work | 5 days | Tue 11/3/15 | Mon 11/9/15 |
| Design Presentation | 1 day | Tue 11/10/15 | Tue 11/10/15 |
| First Draft Final Report | 1 day | Tue 11/10/15 | Tue 11/10/15 |
| Compose Final Report | 16 days | Wed 11/11/15 | Wed 12/2/15 |
| Deliver Fall Report to Client | 1 day | Thu 12/3/15 | Thu 12/3/15 |
| Finalize Design | 2 days | Fri 12/4/15 | Mon 12/7/15 |
| Order Hydraulic Pumps | 6 days | Tue 12/8/15 | Tue 12/15/15 |
| Order hydraulic block and couples | 6 days | Tue 12/8/15 | Tue 12/15/15 |
| Test Existing lines to find pressure and flow loss | 6 days | Wed 12/16/15 | Wed 12/23/15 |
| Fabricate PTO Assembly | 10 days | Thu 12/24/15 | Wed 1/6/16 |
| Build First Prototype | 35 days | Thu 1/7/16 | Wed 2/24/16 |
| Initial Design Performance | 13 days | Thu 2/25/16 | Mon 3/14/16 |
| Revise Prototype Design | 6 days | Tue 3/15/16 | Tue 3/22/16 |
| Final Prototype | 11 days | Wed 3/23/16 | Wed 4/6/16 |
| Test Performance | 5 days | Tue 3/29/16 | Mon 4/4/16 |
| Write Final Report | 9 days | Tue 4/5/16 | Fri 4/15/16 |
| Spring Presentation | 1 day | Tue 4/5/16 | Tue 4/5/16 |

- Dr. Weckler
- Dr. Long
- Mr. Donny Putro
- Mr. Jeffrey Leachman
- Mr. Wayne Kiner
- Varitrac Engineering



- Dunn, J.T., et al. 2007. Tractor with reversible operator position for operation and transport, U.S. Patent No. 7159687B2
- Fadden, D. K., and Fosco, L.D. 1970. Tractor quick hitch attachment, U.S. Patent No. 3531140A
- Honey, G. J. 1991. Swather attachment for bi-directional tractor, U.S. Patent No. 5031394A
- Degelman, W. J. 2000. Multi-functional self-propelled farm tractor, U.S. Patent No. 6160643B1
- Paumier, J. 2002, Vertical underground stump grinding apparatus, U.S. Patent No. 20040098885A1
- ANSI/ASABE Standard AD6489-3:2004, July 2004, “Agricultural vehicles-Mechanical connections between towed and towing vehicles-Part 3: Tractor drawbar,” www.asabe.org
- ANSI/ASABE Standard AD11384:1995 (April 2011), May 2011, “Tractors, machinery for agricultural and forestry, powered lawn and garden equipment – Safety signs and hazard pictorials – General principles,” www.asabe.org
- ASABE/ISO 500-1:2014, Feb 2015, “Agricultural tractors – Rear-mounted power take-off types 1, 2, 3 and 4 - Part 1: General specifications, safety requirements, dimensions for master shield and clearance zone,” www.asabe.org
- ASABE/ISO 500-3:2014, Feb 2015, “Agricultural tractors – Rear-mounted power take-off types 1, 2, 3, and 4 - Part 3: Main PTO dimensions and spline dimensions, location of PTO,” www.asabe.org
- ANSI/ASAE S366.2, May 2004, “Agricultural tractors and machinery – General purpose quick-action hydraulic couples,” ISO 5675:1992, www.asabe.org
- Occupational Safety & Health Administration [OSHA]. 1976. Regulations (Standard – 29 CFR).1928. Retrieved from http://www.osha.gov/pls/oshaweb/owadisp.show_document?p_table=STANDARDS&p_id=10958
- "Farm Injury Resource Center." *Farm Injury Resource Center*. N.p., n.d. Web. 29 Nov. 2015.
- MacDon. (2012). *M155 Self-Propelled Windrower: Operator's Manual*. Winnepeg, CA
- MacDon. (2012). *D65 Harvest Header For Self-Propelled Windrowers: Operator's Manual*. Winnepeg, CA
- Budynas, R. G., Nisbett, J. K., (2015). *Shigley's Mechanical Engineering Design* (10th ed.). New York, NY: McGraw-Hill Education
- Sriastava, A. K., et al., (2012). *Engineering Principles of Agricultural Machines* (2nd ed.). ASABE
- www.engineeringtoolbox.com

Questions?

